



## Plug-in Screw Connector System for Printed Circuit Boards

### TYPE 970-KA /-KB

5 mm spacing - 2 to 12 poles

[Distributor Stock Check](#)

<a href="#">Series</a>	<a href="#">Download PDF</a>	<a href="#">3D Model</a>	<a href="#">Can plug with</a>	<a href="#">How to order</a>	<a href="#">Color specifications</a>	<a href="#">Print</a>
------------------------	------------------------------	--------------------------	-------------------------------	------------------------------	--------------------------------------	-----------------------



970-KA



One possible variation of assembly



RoHS WEEE Pb free compliant

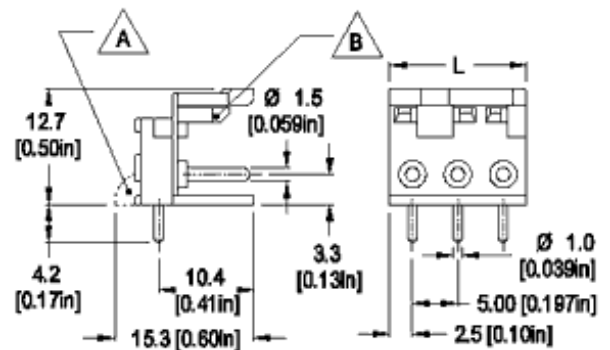

Dimensions: mm (in.)

Length of Connector (L)

L = No. of Poles x Center to Center Spacing

(A) Extended base, 970-KA only

(B) Interlocking latch

When locating connector, allow 0.5 mm clearance around it for process-induced variations.

### Description

These headers are designed to provide a secure interlocking mechanism when an application will be encountering severe vibrations. The header can also be used with the type 971-FBS (-DS) when interlocking and keying features are not required.

- Header
- Plug-In Direction and Wire Entrance Parallel to PCB when plugged with **971-KRFBS (-DS)**, **971-KS**
- 970-KA: Extended base to improve to the stability during wave soldering and to increase the strength during plugging and deplugging.
- End-to-end stackable while maintaining the 5 mm spacing.

### Technical Data

**Center to Center Spacing:** 5 mm (0.197 in.)

**Recommended Hole Diameter in PC Board:**

1.3 mm (0.051 in.)

**Contact Resistance:** typically 1m ohm

### Approval Information

UL File No.E69841



CSA File No.LR24322



Rating	Current(A)	Voltage(V)	Application group	AWG
UL	20	300	B,D	
CSA	10	300	B,D,E	

### International Approvals:



### Material

[Top of page](#)

**Molding:** Polyamide, UL 94, V-2, color grey

**Temperature limits:**

**Short Time:** 140°C (284°F)

**Continuous:** RTI 105°C (221°F)

**Low Limit:** -40°C (-40°F)

**Comparative Tracking Index:** CTI > 175

**Oxygen Index Rating:** 25%

**Solder Pin:** Ø 1 mm (0.04 in.), Tin plated copper alloy

## How to order

**Item** 970-KA /-KB

### Options

CN: Consecutive Numbering (hot stamped numbers)

SM: Special Marking (please provide sketch)

G05: Gold Plating (5 micro inches)

G30: Gold Plating (30 micro inches)

S30: Silver Plating (30 micro inches)

**Note:** Plated component: solder pin

EXTENDED BASE:  
with: A without: B

POLES:  
02 to 12

970-K

/

[Request sample](#)

[Request quote](#)

Quantity

### Accessories

[Add to shopping cart](#)