

Inductive Sensors

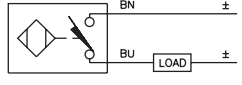
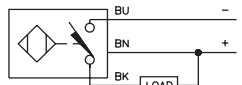
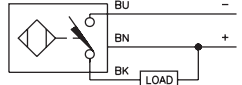
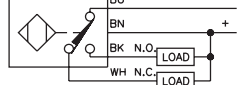
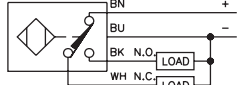
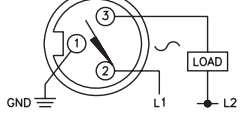

Housing Style	Part Number	ID Number	Features	Sensing Range (mm)	Output	
18 mm - Embeddable, Potted-In Cable, Partial Threading 	Bi 5-M18-AD4X	T4411000		5	2-Wire DC	
	Bi 7-M18-AD4X	T4414535	Ext. Range	7		
	Bi 5U-EM18-AN6X	M1635320	Uprox	5	3-Wire DC NPN	
	Bi 5U-M18-AN6X	M1635120	Uprox	5		
	Bi 8-M18-AN6X	T4615130	Ext. Range	8		
	Bi 5-M18-AN6X	M4611100		5		
	Bi 5-M18-AP6X/S100	M4611004	High Temp. 100°C	5	3-Wire DC PNP	
	Bi 5U-EM18-AP6X	M1635300	Uprox	5		
	Bi 5U-M18-AP6X	M1635100	Uprox	5		
	Bi 8-M18-AP6X	T4615030	Ext. Range	8		
	Bi 5-M18-VN4X	T1571100	Comp. Outputs	5	4-Wire DC NPN	
	Bi 8-M18-VN4X	T4590703	Comp. Outputs	8		
	Bi 5-M18-VP4X	T1561100	Comp. Outputs	5	4-Wire DC PNP	
	Bi 8-M18-VP4X	T4590704	Comp. Outputs	8		
	18 mm - Embeddable, Potted-In Cable, Partial Threading, Teflon Coated 	Bi 5U-MT18-ADZ30X2	M4209410	Uprox	5	2-Wire AC/DC

Output	Switching Freq. (Hz)	Operating Current (mA)	Operating Temp. (°C)	Protection	Housing	Face	End Cap	Power LED	Output LED	Cable Length/ Cable Mat.	Wiring Diagram #	Wiring Diagrams
10-65 VDC	1000	≤100	-25 to +70	IP 67	CPB	PA 12	EPTR	N/A	YE	2M/PVC	1	Diagram 1 
	1000	≤100	-25 to +70	IP 67	CPB	PA 12	EPTR	N/A	YE	2M/PVC	1	
10-30 VDC	2500	≤200	-30 to +85	IP 68	SS	PA 12	EPTR	N/A	YE	2M/PVC	2	Diagram 2 
	2500	≤200	-30 to +85	IP 67	CPB	PA 12	EPTR	N/A	YE	2M/PVC	2	
	500	≤200	-25 to +70	IP 67	SS	PA 12	EPTR	N/A	YE	2M/PVC	2	
	1000	≤200	-25 to +70	IP 67	CPB	PA 12	EPTR	N/A	YE	RK 4T-*	2	
10-30 VDC	1000	≤200	-25 to +100	IP 67	CPB	IRPA	EPTR	N/A	YE	2M/PVC	3	Diagram 3 
	2500	≤200	-30 to +85	IP 68	SS	PA 12	EPTR	N/A	YE	2M/PVC	3	
	2500	≤200	-30 to +85	IP 67	CPB	PA 12	EPTR	N/A	YE	2M/PVC	3	
	500	≤200	-25 to +70	IP 67	SS	PA 12	EPTR	N/A	YE	2M/PVC	3	
10-65 VDC	1000	≤200	-25 to +70	IP 67	CPB	PA 12	EPTR	N/A	YE	2M/PVC	4	Diagram 4 
	500	≤200	-25 to +70	IP 67	SS	PA 12	EPTR	N/A	YE	2M/PVC	4	
10-65 VDC	1000	≤200	-25 to +70	IP 67	CPB	PA 12	EPTR	N/A	YE	2M/PVC	5	Diagram 5 
	500	≤200	-25 to +70	IP 67	SS	PA 12	EPTR	N/A	YE	2M/PVC	5	
20-250 VAC 10-300 VDC	20	≤400/300	-30 to +85	IP 67	TC	TC	EPTR	GN	YE	2M/PVC	6	Diagram 6 

WIRING DIAGRAMS

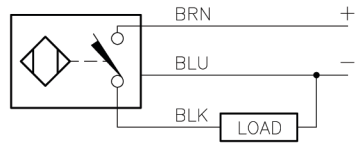

OUTPUT: AP6X

SHORT-CIRCUIT AND OVERLOAD PROTECTED

LOCKNUT LN-M18

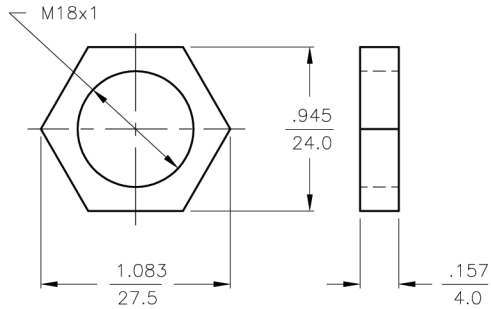

SPECIFICATIONS

OPERATING VOLTAGE	10-30 VDC
RIPPLE	≤ 10%
DIFFERENTIAL TRAVEL (HYSTERESIS)	3-15% (5% TYPICAL)
VOLTAGE DROP ACROSS CONDUCTING SENSOR	≤ 1.8 V at 200 mA
OUTPUT FUNCTION	NORMALLY OPEN 3-WIRE DC SELF-CONTAINED
TTL COMPATIBLE	NO
SHORT-CIRCUIT PROTECTED	YES
TRIGGER CURRENT FOR OVERLOAD PROTECTION	≥ 220 mA
CONTINUOUS LOAD CURRENT	≤ 200 mA
OFF-STATE (LEAKAGE) CURRENT	< 100µ A
NO-LOAD CURRENT	≤ 15 mA
TIME DELAY BEFORE AVAILABILITY	≤ 8 ms
POWER-ON EFFECT PROTECTION	INCORPORATED
REVERSE POLARITY PROTECTION	INCORPORATED
WIRE-BREAK PROTECTION	INCORPORATED
PROTECTION AGAINST TRANSIENTS	EN 60947-5-2
OPERATING TEMPERATURE	-25°C to +70°C (-13°F to +158°F) -30°C to +85°C (-22°F to +185°F) W/15% TEMP. DRIFT
ENCLOSURE	MEETS NEMA 1, 3, 4, 6, 13 AND IEC IP67
SHOCK	30 g, 11 ms
VIBRATION	55 Hz, 1 mm AMPLITUDE (IN ALL 3 PLANES)
LED FUNCTION	YELLOW: OUTPUT ENERGIZED
RATED OPERATING DISTANCE(Sn)	5 mm = .197" (NOMINAL)
SWITCHING FREQUENCY	2500 Hz
REPEATABILITY	≤ 2% of RATED OPERATING DISTANCE
EMBEDDABLE (SHIELDED)	YES

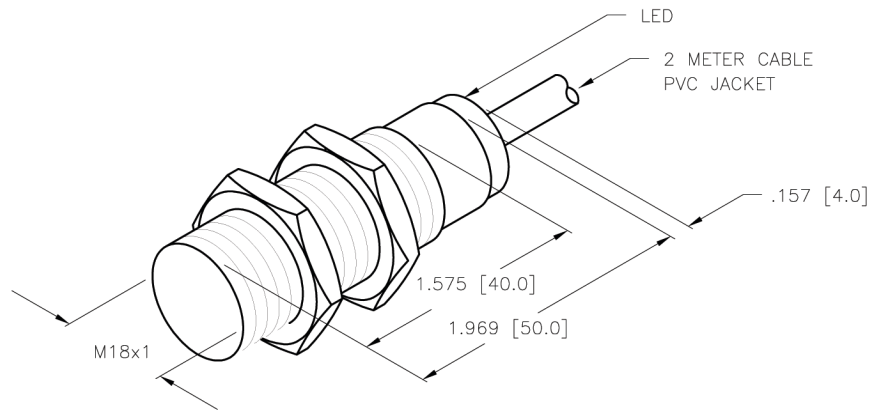

NOTES:

1. UPROX HAS IMMUNITY TO AC AND DC WELD FIELDS.

RELATED DOCUMENTS 1. 2. 3. 4.	3RD ANGLE PROJECTION 	THIS DRAWING IS PROPERTY OF TURCK INC. USE OF THIS DOCUMENT WITHOUT WRITTEN PERMISSION IS PROHIBITED.		TURCK INC High Technology Sensors and Automation Controls	
	MATERIAL BRASS BARREL	TOLERANCES UNLESS OTHERWISE SPECIFIED .X ±0.02 .XX ±0.01 .XXX ±0.005 ANGLES ±1° ALL MILLIMETER DIMENSIONS ARE REFERENCE ONLY	DRFT IK DATE 7/18/97	DESCRIPTION Bi5U-M18-AP6X	REV A
FINISH COPPER/NICKEL/ CHROME PLATING	UNIT OF MEASUREMENT INCH [MILLIMETER]	DSGN	SCALE NONE	IDENTIFICATION NO. M1635100	FILE: M1635100
A DRAWING RELEASE	RDS 08/27/02 5504	DO NOT SCALE THIS DRAWING		SHEET 1 OF 1	
REV DESCRIPTION	BY DATE ECO NO.				