

Inductive Sensors



Housing Style - Rectangular	Part Number	ID Number	Features	Embeddable	Sensing Range (mm)	Output
CP40 - Embeddable/Nonembeddable, Terminal Chamber 	Bi15-CP40-AD4X	M4477000		•	15	2-Wire DC
	Ni20-CP40-AD4X	M4477100			20	
	Bi15U-CP40-AN6X2	M1623512	<i>Uprox</i>	•	15	3-Wire DC NPN
	Bi15-CP40-AN6X2	M1623000		•	15	
	Ni20-CP40-AN6X2	M1623100			20	
	Ni25U-CP40-AN6X2	M1623711	<i>Uprox</i>		25	
	Ni40U-CP40-AN6X2	M1623610	<i>Uprox, Ext. Range</i>		40	
	Bi15-CP40-AN6X2/S97	M1623001	<i>Low Temp -40° C</i>	•	15	
	Bi15U-CP40-AP6X2	M1623502	<i>Uprox</i>	•	15	3-Wire DC PNP
	Bi15-CP40-AP6X2	M1603000		•	15	
	Ni20-CP40-AP6X2	M1603100			20	
	Ni25U-CP40-AP6X2	M1623701	<i>Uprox</i>		25	
	Ni40U-CP40-AP6X2	M1623602	<i>Uprox</i>		40	
	Ni50U-CP40-AP6X2	M1625842	<i>Uprox, Ext. Range</i>		50	
	Bi15U-CP40-VN4X2	M1540511	<i>Uprox</i>	•	15	4-Wire NPN
	Bi15-CP40-VN4X2	M1525000	<i>Comp. Outputs</i>	•	15	
	Bi15-CP40-VN4X2/S100	M1514400	<i>High Temp. 100°C</i>	•	15	
	Bi20-CP40-VN4X2	M1579221	<i>Ext. Range</i>	•	20	
	Ni20-CP40-VN4X2	M1525100	<i>Comp. Outputs</i>		20	
	Ni20-CP40-VN4X2/S100	M1527200	<i>High Temp. 100°C</i>		20	
	Ni20NF-CP40-VN4X2	M1528200	<i>Nonferrous</i>		20	
	Ni35-CP40-VN4X2	M1525400	<i>Comp. Outputs</i>		35	
	Ni40U-CP40-VN4X2	M1540611	<i>Uprox, Ext. Range</i>		40	
	Ni50U-CP40-VN4X2	M1625807	<i>Uprox</i>		50	
	Bi15U-CP40-VP4X2	M1540501	<i>Uprox</i>	•	15	4-Wire PNP
	Bi15-CP40-VP4X2	M1501000	<i>Comp. Outputs</i>	•	15	
	Bi15-CP40-VP4X2/S100	M1501900	<i>High Temp. 100°C</i>	•	15	
	Bi20-CP40-VP4X2	M1501200	<i>Ext. Range</i>	•	20	
	Ni20-CP40-VP4X2	M1501100	<i>Comp. Outputs</i>		20	
	Ni20-CP40-VP4X2/S100	M1502000	<i>High Temp. 100°C</i>		20	
	Ni20NF-CP40-VP4X2	M1508200	<i>Nonferrous</i>		20	
	Ni35-CP40-VP4X2	M1501400	<i>Comp. Outputs</i>		35	
	Ni40U-CP40-VP4X2	M1540601	<i>Uprox, Ext. Range</i>		40	
	Ni50U-CP40-VP4X2	M1538303	<i>Uprox</i>		50	
	Bi15U-CP40-ASIX2	M1901003	<i>Uprox</i>	•	15	2-Wire ASI-BUS
	Ni40U-CP40-ASIX2	M1901008	<i>Uprox</i>		40	

Voltage	Switching Freq. (Hz)	Operating Current (mA)	Operating Temp. (°C)	Protection	Housing	Front Cap/Face	Power LED	Output LED	Mating Cord, Cable Length/Jacket	Wiring Diagram #	Wiring Diagrams
10-65 VDC	150	≤100	-25 to +70	IP 67	PBT	PBT	N/A	YE	- - - -	1	Diagram 1
	150	≤100	-25 to +70	IP 67	PBT	PBT	N/A	YE	- - - -	1	
10-30 VDC	250	≤200	-30 to +85	IP 67	PBT	PBT	GN	YE	- - - -	2	Diagram 2
	150	≤200	-25 to +70	IP 67	PBT	PBT	GN	YE	- - - -	2	
	150	≤200	-25 to +70	IP 67	PBT	PBT	GN	YE	- - - -	2	
	250	≤200	-30 to +85	IP 67	PBT	PBT	GN	YE	- - - -	2	
	250	≤200	-30 to +85	IP 67	PBT	PBT	GN	YE	- - - -	2	
10-30 VDC	250	≤200	-30 to +85	IP 67	PBT	PBT	GN	YE	- - - -	3	Diagram 3
	150	≤200	-25 to +70	IP 67	PBT	PBT	GN	YE	- - - -	3	
	150	≤200	-25 to +70	IP 67	PBT	PBT	GN	YE	- - - -	3	
	250	≤200	-30 to +85	IP 67	PBT	PBT	GN	YE	- - - -	3	
	250	≤200	-30 to +85	IP 67	PBT	PBT	GN	YE	- - - -	3	
10-65 VDC	250	≤200	-30 to +85	IP 67	PBT	PBT	GN	YE	- - - -	4	Diagram 4
	150	≤200	-25 to +70	IP 67	PBT	PBT	GN	YE	- - - -	4	
	150	≤200	-25 to +100	IP 67	PBT	PBT	GN	YE	- - - -	4	
	100	≤200	-25 to +70	IP 67	PBT	PBT	GN	YE	- - - -	4	
	150	≤200	-25 to +70	IP 67	PBT	PBT	GN	YE	- - - -	4	
	150	≤200	-25 to +100	IP 67	PBT	PBT	GN	YE	- - - -	4	
	100	≤200	0 to +60	IP 67	PBT	PBT	GN	YE	- - - -	4	
	150	≤200	-25 to +70	IP 67	PBT	PBT	GN	YE	- - - -	4	
10-65 VDC	250	≤200	-30 to +85	IP 67	PBT	PBT	GN	YE	- - - -	4	Diagram 5
	250	≤200	-30 to +85	IP 67	PBT	PBT	GN	YE	- - - -	4	
	250	≤200	-30 to +85	IP 67	PBT	PBT	GN	YE	- - - -	4	
	250	≤200	-30 to +85	IP 67	PBT	PBT	GN	YE	- - - -	4	
	250	≤200	-30 to +85	IP 67	PBT	PBT	GN	YE	- - - -	4	
	250	≤200	-30 to +85	IP 67	PBT	PBT	GN	YE	- - - -	4	
	250	≤200	-30 to +85	IP 67	PBT	PBT	GN	YE	- - - -	4	
	250	≤200	-30 to +85	IP 67	PBT	PBT	GN	YE	- - - -	4	
	250	≤200	-30 to +85	IP 67	PBT	PBT	GN	YE	- - - -	4	
	250	≤200	-30 to +85	IP 67	PBT	PBT	GN	YE	- - - -	4	
10-65 VDC	250	≤200	-30 to +85	IP 67	PBT	PBT	GN	YE	- - - -	5	Diagram 6
	150	≤200	-25 to +70	IP 67	PBT	PBT	GN	YE	- - - -	5	
	150	≤200	-25 to +100	IP 67	PBT	PBT	GN	YE	- - - -	5	
	100	≤200	-25 to +70	IP 67	PBT	PBT	GN	YE	- - - -	5	
	150	≤200	-25 to +70	IP 67	PBT	PBT	GN	YE	- - - -	5	
	150	≤200	-25 to +100	IP 67	PBT	PBT	GN	YE	- - - -	5	
	100	≤200	0 to +60	IP 67	PBT	PBT	GN	YE	- - - -	5	
	150	≤200	-25 to +70	IP 67	PBT	PBT	GN	YE	- - - -	5	
	250	≤200	-30 to +85	IP 67	PBT	PBT	GN	YE	- - - -	5	
	250	≤200	-30 to +85	IP 67	PBT	PBT	GN	YE	- - - -	5	
18-33 VDC	200	N/A	-30 to +85	IP 67	PBT	PBT	GN	YE	- - - -	6	
	200	N/A	-30 to +85	IP 67	PBT	PBT	GN	YE	- - - -	6	

WIRING DIAGRAM

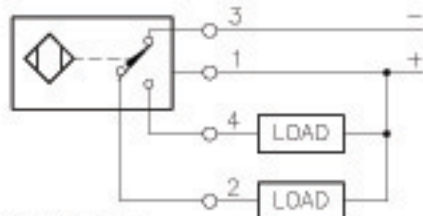

OUTPUT: VN4X2

SHORT-CIRCUIT AND OVERLOAD PROTECTED

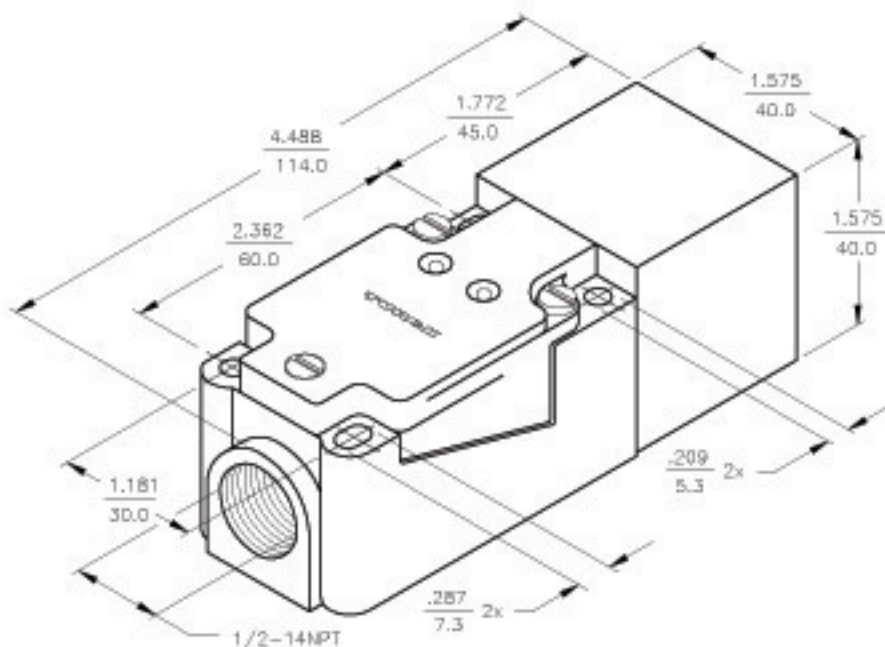

SPECIFICATIONS

OPERATING VOLTAGE	10-85 VDC (SHORT-CIRCUIT PROTECTED)
RIPLLE	≤ 10%
HYSTERESIS (DIFFERENTIAL TRAVEL)	3-15% (5% TYPICAL)
VOLTAGE DROP ACROSS CONDUCTING SENSOR	≤ 1.8 V at 200 mA
OUTPUT FUNCTION	COMPLEMENTARY OUTPUT ONE N.O., ONE N.C. (SPDT)
TTL COMPATIBLE	NO
SHORT-CIRCUIT PROTECTED	YES
TRIGGER CURRENT FOR OVERLOAD PROTECTION	≥ 220 mA
CONTINUOUS LOAD CURRENT	≤ 200 mA
LEAKAGE (OFF-STATE) CURRENT	< 10 μ A
NO-LOAD CURRENT	4.0-9.5 mA
TIME DELAY BEFORE AVAILABILITY	≤ 25 ms
POWER-ON EFFECT PROTECTION	INCORPORATED
POLARITY INVERSION PROTECTION	INCORPORATED
WIRE-BREAK PROTECTION	INCORPORATED
PROTECTION AGAINST TRANSIENTS	2 kV, 1 ms, 1 kA
OPERATING TEMPERATURE	-25°C to +70°C (-13°F to +158°F)
ENCLOSURE	MEETS NEMA 1, 3, 4X, 6, 13 AND IEC IP67
SHOCK	30 g, 11 ms
VIBRATION	55 Hz, 1 mm AMPLITUDE (IN ALL 3 PLANES)
LED FUNCTION	GREEN: POWER ON YELLOW: OUTPUT ENERGIZED
SENSING RANGE	15 mm = .591" (NOMINAL)
SWITCHING FREQUENCY	150 Hz
REPEATABILITY	≤ 2%
SHIELDED	YES

NOTES:

1. SENSING HEAD TURNS TO ACCOMMODATE 9 DIFFERENT SENSING POSITIONS.

RELATED DOCUMENTS 1. 2. 3. 4.	3RD ANGLE PROJECTION 	THIS DRAWING IS PROPERTY OF TURCK INC. USE OF THIS DOCUMENT WITHOUT WRITTEN PERMISSION IS PROHIBITED.		 High Technology Sensors and Automation Controls											
	MATERIAL PLASTIC HOUSING	TOLERANCES UNLESS OTHERWISE SPECIFIED .X ±0.02 .XX ±0.01 .XXX ±0.005 ANGLES ±1° ALL MILLIMETER DIMENSIONS ARE REFERENCE ONLY	DWGT SMV USDR			DATE 10/27/88 SCALE NONE	DESCRIPTION Bi15-CP40-VN4X2								
FINISH		UNIT OF MEASUREMENT INCH [MILLIMETER]		IDENTIFICATION NO. M1525000	REV D										
<table border="1"> <tr> <td>CD</td> <td>UPDATE TO CURRENT TITLEBLOCK</td> <td>RDS</td> <td>07/16/03</td> <td>5504</td> </tr> <tr> <td>REV</td> <td>DESCRIPTION</td> <td>BY</td> <td>DATE</td> <td>EDD NO.</td> </tr> </table>		CD	UPDATE TO CURRENT TITLEBLOCK	RDS	07/16/03	5504	REV	DESCRIPTION	BY	DATE	EDD NO.	DO NOT SCALE THIS DRAWING		FILE: M1525000	SHEET 1 OF 1
CD	UPDATE TO CURRENT TITLEBLOCK	RDS	07/16/03	5504											
REV	DESCRIPTION	BY	DATE	EDD NO.											