

Inductive Sensors



Housing Style	Part Number	ID Number	Features	Sensing Range (mm)	Output
6.5 mm - Embeddable, Miniature Smooth Barrel, Potted-In Cable 	Bi 1.5-EH6.5K-AN6X	S4610640	Short Barrel	1.5	3-Wire DC NPN
	Bi 2-EH6.5K-AN6X	S4610100	Short Barrel	2	
	Bi 1.5-EH6.5K-AP6X	S4610540	Short Barrel	1.5	3-Wire DC PNP
	Bi 2-EH6.5K-AP6X	S4610000	Short Barrel	2	
	Bi 1.5-EH6.5K-Y1	S1004600	Short Barrel	1.5	2-Wire DC NAMUR
	6.5 mm - Embeddable, Miniature Smooth Barrel, Potted-In Cable 	Bi 1.5-EH6.5-AN6X	S4612100		1.5
Bi 2-EH6.5-AN6X		S4612300	Ext. Range	2	
Bi 2U-EH6.5-AN6X		S4281170	Uprox	2	
Bi 1.5-EH6.5-AP6X		S4612000		1.5	3-Wire DC PNP
Bi 1.5U-EH6.5-AP6X			Uprox	1.5	
Bi 2-EH6.5-AP6X		S4612200	Ext. Range	2	
Bi 2U-EH6.5-AP6X		S4281150	Uprox	2	
Bi 1.5-EH6.5-AP6X/S100		S4612001	High Temp. 100°C	1.5	
Bi 1.5-H6.5-Y1X		S4004810		1.5	2-Wire DC NAMUR
6.5 mm - Embeddable, Miniature Smooth Barrel, Potted-In Cable 	Bi 1.5-H6.5M-AN7	S4708100	TTL Compatible	1.5	3-Wire DC NPN



Voltage	Switching Freq. (Hz)	Operating Current (mA)	Operating Temp. (°C)	Protection	Housing	Face	End Cap	Power LED	Output LED	Cable Length/ Cable Mat.	Wiring Diagram #	Wiring Diagrams
10-30 VDC	3000	≤150	-25 to +70	IP 67	SS	PA 12	TROG	N/A	YE	2M/PUR	1	Diagram 1
	3000	≤150	-25 to +70	IP 67	SS	PA 12	TROG	N/A	YE	2M/PUR	1	
10-30 VDC	3000	≤150	-25 to +70	IP 67	SS	PA 12	TROG	N/A	YE	2M/PUR	2	Diagram 2
	3000	≤150	-25 to +70	IP 67	SS	PA 12	TROG	N/A	YE	2M/PUR	2	
5-30 VDC	5000	Remote	-25 to +70	IP 67	SS	PA 12	TROG	N/A	N/A	2M/PVC	3	Diagram 3
10-30 VDC	3000	≤150	-25 to +70	IP 67	SS	PA 12	TROG	N/A	YE	2M/PUR	1	
	3000	≤150	-25 to +70	IP 67	SS	PA 12	TROG	N/A	YE	2M/PUR	1	
	1000	≤150	-25 to +70	IP 68	SS	PA 12	TROG	N/A	YE	2M/PUR	1	
10-30 VDC	3000	≤150	-25 to +70	IP 67	SS	PA 12	TROG	N/A	YE	2M/PUR	2	Diagram 3
	2000	≤150	-30 to +85	IP 68	SS	PA 12	TROG	N/A	YE	2M/PUR	2	
	3000	≤150	-25 to +70	IP 67	SS	PA 12	TROG	N/A	YE	2M/PUR	2	
	1000	≤150	-30 to +85	IP 68	SS	PA 12	TROG	N/A	YE	2M/PUR	2	
	3000	Remote	-25 to +100	IP 67	CPB	EPTR	TROG	N/A	YE	2M/PVC	3	
5-30 VDC	3000	≤150	-25 to +70	IP 67	SS	PA 12	TROG	N/A	YE	2M/PUR	3	
10-30 VDC	2000	≤150	-25 to +70	IP 67	SS	PA 12	TROG	N/A	YE	2M/PUR	1	

WIRING DIAGRAM

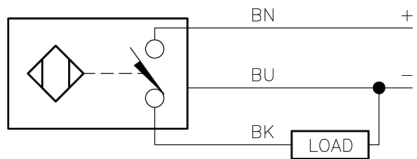

OUTPUT: AP6X

SHORT-CIRCUIT AND OVERLOAD PROTECTED

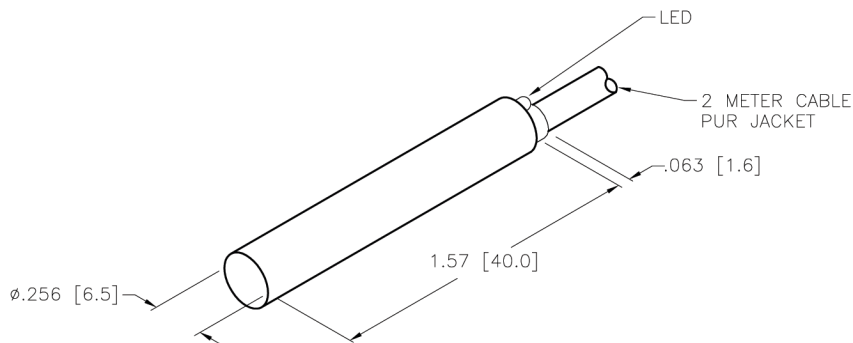

SPECIFICATIONS

OPERATING VOLTAGE	10-30 VDC
RIPPLE	≤ 10%
DIFFERENTIAL TRAVEL (HYSTERESIS)	3-15% (5% TYPICAL)
VOLTAGE DROP ACROSS CONDUCTING SENSOR	≤ 1.8 V at 150 mA
OUTPUT FUNCTION	NORMALLY OPEN 3-WIRE DC SELF-CONTAINED
SHORT-CIRCUIT PROTECTED	YES
TRIGGER CURRENT FOR OVERLOAD PROTECTION	≥ 170 mA
CONTINUOUS LOAD CURRENT	≤ 150 mA
OFF-STATE (LEAKAGE) CURRENT	<10 μA
NO LOAD CURRENT	1.0-9.5mA
MAXIMUM APPROACH VELOCITY	≤ 1 ms
TIME DELAY BEFORE AVAILABILITY	≤ 8 ms
REVERSE POLARITY PROTECTION	INCORPORATED
WIRE-BREAK PROTECTION	INCORPORATED
POWER-ON EFFECT PROTECTION	Per IEC 947-5-2
PROTECTION AGAINST TRANSIENTS	Per EN 60947-5-2
OPERATING TEMPERATURE	-25°C to +70°C (-13°F to +158°F)
ENCLOSURE	MEETS NEMA 1,3,4,4x,6,13 AND IEC IP 67
SHOCK	30 g, 11 ms
VIBRATION	55 Hz, 1 mm AMPLITUDE (IN ALL 3 PLANES)
LED FUNCTION	YELLOW: OUTPUT ENERGIZED
RATED OPERATING DISTANCE(S _n)	1.5 MM = .059" (NOMINAL)
SWITCHING FREQUENCY	3000 Hz
TEMPERATURE DRIFT	≤ 0.1mm
REPEATABILITY	≤ 2% OF NOMINAL SENSING RANGE
EMBEDDABLE (SHIELDED)	YES

SOURCE DRAWING - FOR REFERENCE ONLY

NOTES: 1. MATERIALS:

- BARREL - STAINLESS STEEL
- SENSING FACE - PA12-GF30 PLASTIC
- END CAP - TROGAMID T

RELATED DOCUMENTS 1. 2. 3. 4.	3RD ANGLE PROJECTION	THIS DRAWING IS PROPERTY OF TURCK INC. USE OF THIS DOCUMENT WITHOUT WRITTEN PERMISSION IS PROHIBITED.	 High Technology Sensors and Automation Controls	
MATERIAL SEE NOTE 1	TOLERANCES UNLESS OTHERWISE SPECIFIED	DRFT JBJ	DATE 06/18/02	DESCRIPTION Bi 1.5-EH6.5-AP6X
FINISH	.X ±0.02 .XX ±0.01 .XXX ±0.005 ANGLES ±1°	DSGN	SCALE 1=1.0	
		UNIT OF MEASUREMENT INCH [MILLIMETER]		IDENTIFICATION NO. S4612000
		DO NOT SCALE THIS DRAWING		REV A
A	DRAWING RELEASE	BY JBJ	DATE 06/18/02	FILE: S4612000
REV	DESCRIPTION	BY	DATE	ECO NO.