



XVBC02



XVBC020

















XVBC11







XVBC12

Accessories Common to Beacon and Indicating Banks

Description	Characteristics		Catalog Number	
	IN	mm		
Support tube	3.94	100	XVBC02	
	15.75	400	XVBC03	
	31.50	800	XVBC04	
Support tube concealment cover	3.94	100	XVBC020	
	15.75	400	XVBC030	
	31.50	800	XVBC040	
Mounting tulip with gasket	For mounting on tube XVBC0*		XVBC11	
Wall mount bracket	For direct mounting on base unit or with tulip XVBC11 + tube XVBC0*		XVBC12	
Incandescent bulbs bayonet type BA 15d, 10 W	12 Vac/dc		DL1BLJ	
	24 Vac/dc		DL1BLB	
	48 Vac/dc		DL1BLE	
	120 Vac/dc		DL1BLG	
	230 Vac/dc		DL1BLM	
Incandescent bulbs bayonet type BA 15d, 7 W	12 Vac/dc		DL1BEJ	
	24 Vac/dc		DL1BEB	
	48 Vac/dc		DL1BEE	
	120 Vac/dc		DL1BEG	
	230 Vac/dc		DL1BEM	
LEDs bayonet type BA 15d (sold singly)	24 Vac/dc	White	DL1BDB1	
		Green	DL1BDB3	
		Red	DL1BDB4	
		Blue	DL1BDB6	
	120 Vac	Yellow-orange	DL1BDB8	
		White	DL1BDG1	
		Green	DL1BDG3	
		Red	DL1BDG4	
		Blue	DL1BDG6	
		Yellow-orange	DL1BDG8	
Adapter for side entry through base unit	With CM12 (pg 13.5) cable gland, for cable size of 0.4 to 0.55 in. (10 to 14 mm) diameter		XVBC14	
Conduit adapter	1/2" NPT (for customer supplied tubing)		XVBC00	

Accessories Specific to Indicating Banks

Description	Characteristics	Catalog Number	
Set of colored markers	6 colors	XVBC22	
Set of 5 legend holders	Identification of stacked units on base	XVBC23	
Sheet of 85 legends for legend holder (XVBC23)	Identification of stacked units on base	XVBCY1	
Sheet of 52 legends	Identification of stacked units on locking ring	XVBCY2	

Wiring Diagrams, Base Units

Screw terminals
 Torque to 4.4 in-lb (0.5 N•m)

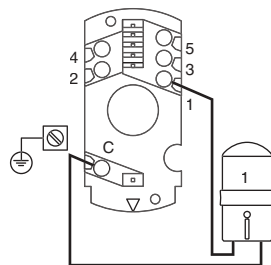

2 x #16 AWG (1.5 mm²)
 1 x #14 AWG (2.5 mm²)

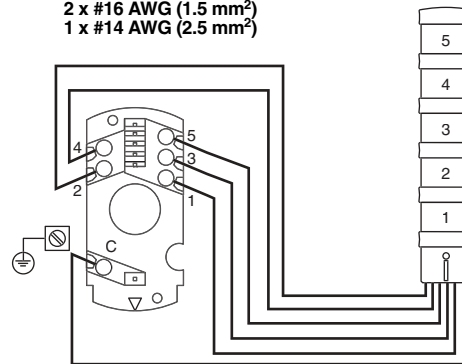

For additional information, reference Catalog #9001CT0001.