



DURA-Vue™

MLV12 Series Dura-Vue™ Sensors

- Rugged die-cast metal housing frame
- High-visibility, dual-position indicator LEDs
- Thru-hole or dovetail mounting
- Extreme low-temperature operation (-40°C/F) available



4 IN 1 ONE SENSOR 4 output options from 1 sensor: NPN normally open, NPN normally closed, PNP normally open, or PNP normally closed



Diffuse Mode with Background Evaluation

See page 502

Features:

- Reliable detection of all surfaces regardless of color or shape
- Cross-talk immunity

Sensing Range: 150 mm

Output: 4-in-1

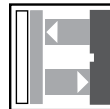

Diffuse Mode with Background Suppression

See page 503

Features:

- Cost-effective electronic background suppression
- Cross-talk immunity

Sensing Range: 250 mm

Outputs: PNP, 4-in-1

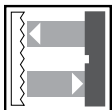

Retro-Reflective Mode

See pages 504-505

Features:

- Laser transmitter versions available
- Cross-talk immunity

Sensing Range: 450 mm, 5 m, 15 m

Outputs: NPN, PNP, 4-in-1

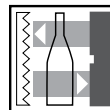

Retro-Reflective Mode for Clear Object Detection

See page 506

Features:

- Remote teach capability
- Cross-talk immunity

Sensing Range: 3 m

Outputs: PNP, 4-in-1

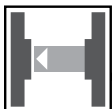

Thru-Beam Mode

See page 507

Features:

- Remote teach capability
- Visible red LED in receiver as alignment aid



Sensing Range: 16 m

Outputs: 4-in-1

See pages 508-512 for MLV12 Series specifications, wiring and dimensions.



Diffuse Mode with Background Suppression

Specifications		
SENSING RANGE	20-250 mm	20-250 mm
SENSITIVITY ADJUSTMENT	Yes (50-250 mm)	Yes (50-250 mm)
MODEL NUMBER(S)	—	MLV12-8-H-250-RT/47/65b/124 •
	MLV12-8-H-250-RT/65b/115/128 •	MLV12-8-H-250-RT/65b/124/128 ✘
	—	MLV12-8-H-250-IR/65b/124/128 ✘
OUTPUT	/47	2 PNP
	/128	4-in-1*
LOAD CURRENT	200 mA max.	200 mA max.
SUPPLY VOLTAGE	10-30 VDC	10-30 VDC
CURRENT CONSUMPTION	≤ 55 mA	≤ 55 mA
RESPONSE TIME	0.5 ms	0.5 ms
SWITCHING FREQUENCY	1 kHz	1 kHz
LIGHT SPOT DIAMETER	≈ 8 mm at a range of 250 mm	≈ 8 mm at a range of 250 mm
LIGHT BEAM ANGLE	1.5°	1.5°
LIGHT SOURCE	-RT	Visible red LED 660 nm
	-IR	Infrared LED 880 nm
AMBIENT LIGHT RESISTANCE	≤ 30,000 lux	≤ 30,000 lux
TEMPERATURE RANGE	WORKING	-40 °F to +140 °F
	STORAGE	-40 °F to +167 °F
ELECTRICAL CONNECTION	 2.5-meter cable, PVC covered 5-conductor, #24 AWG	 Quick disconnect type V15
	ADDITIONAL DATA	See pages 508-512

*NPN normally open, NPN normally closed, PNP normally open, or PNP normally closed



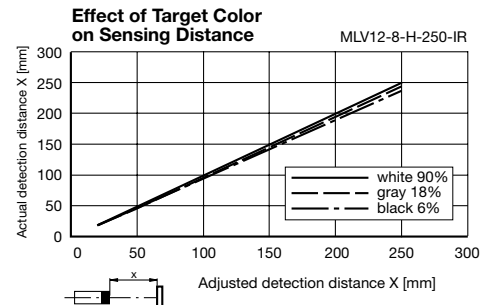
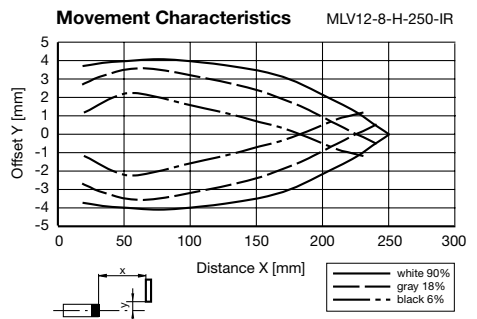
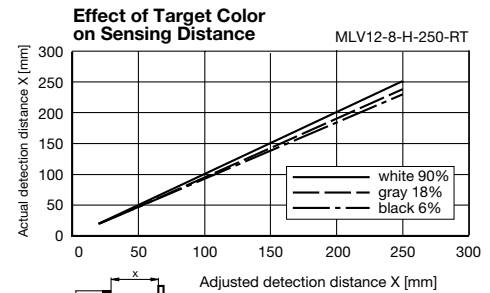
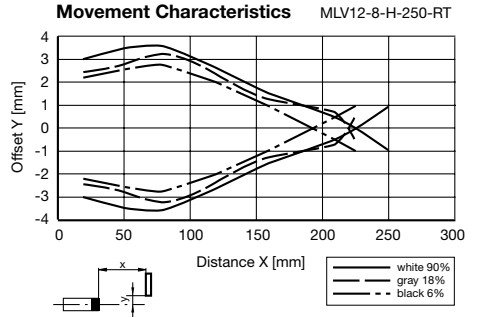

Sensing Characteristics



Photoelectric MLV12 Series Dura-Vue™



Retro-Reflective Mode

Specifications	Laser*		
SENSING RANGE	100-450 mm (effective range)	0-15 m	0-15 m
SENSITIVITY ADJUSTMENT	Yes	Yes	Yes
REFLECTOR DISTANCE	20 mm-4.3 m	0-15 m	0-15 m
POLARIZED FILTER	Yes	Yes	Yes
MODEL NUMBER(S)	MLV12-54-LAS-300/76b/110/124 •	MLV12-54-LAS/76b/110/115 •	MLV12-54-LAS/76b/110/124 ⚡
OUTPUT  /110	4-in-1†	4-in-1†	4-in-1†
LOAD CURRENT	100 mA max.	100 mA max.	100 mA max.
SUPPLY VOLTAGE	10-30 VDC	10-30 VDC	10-30 VDC
CURRENT CONSUMPTION	≤ 40 mA	≤ 40 mA	≤ 40 mA
RESPONSE TIME	0.2 ms	0.2 ms	0.2 ms
SWITCHING FREQUENCY	2.5 kHz	2.5 kHz	2.5 kHz
LIGHT SPOT DIAMETER	≈ 0.5 mm at a range of 150-400 mm (0.3 mm min. target diameter)	≈ 5 mm at a range of 15m	≈ 5 mm at a range of 15 m
LIGHT BEAM ANGLE	0.1°	0.02°	0.02°
LIGHT SOURCE	Visible red laser 650 nm Class 2	Visible red laser 650 nm Class 2	Visible red laser 650 nm Class 2
AMBIENT LIGHT RESISTANCE	≤ 50,000 lux	≤ 50,000 lux	≤ 50,000 lux
TEMPERATURE RANGE	<i>WORKING</i> +14 °F to +122 °F <i>STORAGE</i> -4 °F to +149 °F	+14 °F to +122 °F -4 °F to +149 °F	+14 °F to +122 °F -4 °F to +149 °F
ELECTRICAL CONNECTION	 Quick disconnect type V15	 2.5-meter cable, PVC covered 5-conductor, #24 AWG	 Quick disconnect type V15
ADDITIONAL DATA	<i>See pages 508-512</i>		

* Micro-structure corner-cube reflectors are recommended with laser retro-reflective mode sensors.

†NPN normally open, NPN normally closed, PNP normally open, or PNP normally closed

Sensing Characteristics

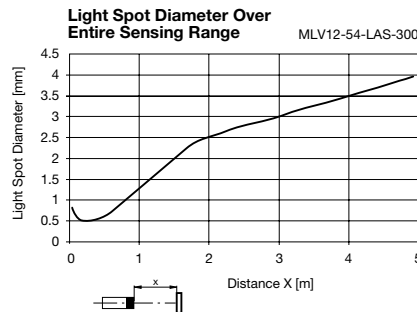
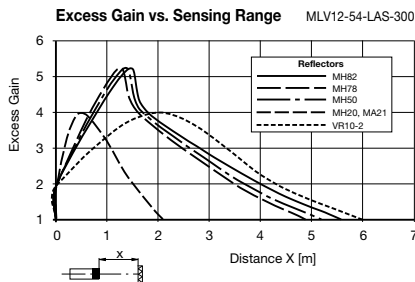

CAUTION

LASER RADIATION –
DO NOT STARE INTO BEAM

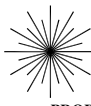
 650nm LASER LIGHT
1mW PEAK POWER

PRODUCT CONFORMS TO 21CFR1040
CLASS II LASER PRODUCT

◀ AVOID EXPOSURE – Laser radiation
is emitted from this aperture

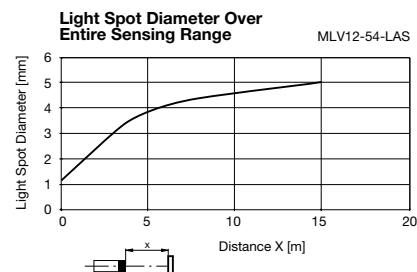
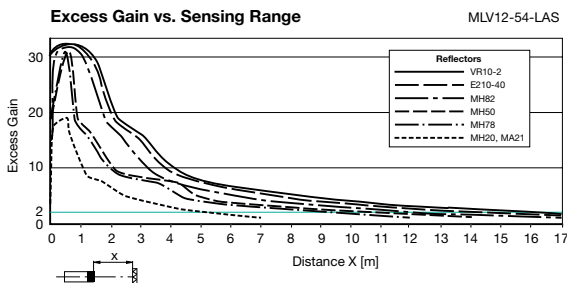



Retro-Reflective Mode for Clear Object Detection

Specifications

SENSING RANGE	0-3 m
SENSITIVITY ADJUSTMENT	Yes (5-position potentiometer)
REFLECTOR DISTANCE	0-3 m
POLARIZED FILTER	Yes
MODEL NUMBER(S)	MLV12-54-G/32/82g/124 • MLV12-54-G/76b/124/128 ⚡
OUTPUT	/32 1 PNP /128 4-in-1*
LOAD CURRENT	200 mA max.
SUPPLY VOLTAGE	10-30 VDC
CURRENT CONSUMPTION	≤ 55 mA
RESPONSE TIME	0.5 ms
SWITCHING FREQUENCY	1 kHz
LIGHT SPOT DIAMETER	≈ 80 mm at a range of 3 m
LIGHT BEAM ANGLE	1.5°
LIGHT SOURCE	Visible red LED 660 nm
AMBIENT LIGHT RESISTANCE	≤ 40,000 lux
TEMPERATURE RANGE	<i>WORKING</i> -40 °F to +140 °F <i>STORAGE</i> -40 °F to +167 °F
ELECTRICAL CONNECTION	 Quick disconnect type V15
ADDITIONAL DATA	See pages 508-512

*NPN normally open, NPN normally closed, PNP normally open, or PNP normally closed

Sensing Characteristics

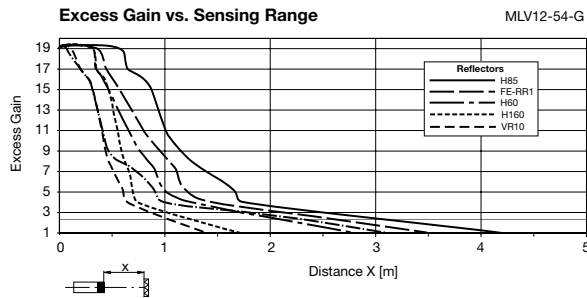



Thru-Beam Mode

Specifications

SENSING RANGE		0-16 m	0-16 m
SENSITIVITY ADJUSTMENT		Yes	Yes
MODEL NUMBER(S)	Transmitter	M12-F1/76b/115 •	M12-F1/76b/124 ⚡
	Receiver	MV12-F1/82b/115/128 •	MV12-F1/82b/124/128 ⚡
OUTPUT	/128	4-in-1*	4-in-1*
LOAD CURRENT		200 mA max.	200 mA max.
SUPPLY VOLTAGE		10-30 VDC	10-30 VDC
CURRENT CONSUMPTION		≤ 35 mA transmitter ≤ 45 mA receiver	≤ 35 mA transmitter ≤ 45 mA receiver
RESPONSE TIME		0.5 ms	0.5 ms
SWITCHING FREQUENCY		1 kHz	1 kHz
LIGHT SPOT DIAMETER		≈ 420 mm at a range of 16 m (12 mm min. target diameter)	≈ 420 mm at a range of 16 m (12 mm min. target diameter)
LIGHT BEAM ANGLE		1.5°	1.5°
LIGHT SOURCE		2 visible red LEDs 660 nm	2 visible red LEDs 660 nm
AMBIENT LIGHT RESISTANCE		≤ 40,000 lux	≤ 40,000 lux
TEMPERATURE RANGE	WORKING	-40 °F to +140 °F	-40 °F to +140 °F
	STORAGE	-40 °F to +167 °F	-40 °F to +167 °F
ELECTRICAL CONNECTION		2.5-meter cable, PVC covered 5-conductor, #24 AWG	Quick disconnect type V15
ADDITIONAL DATA		See pages 508-512	

*NPN normally open, NPN normally closed, PNP normally open, or PNP normally closed

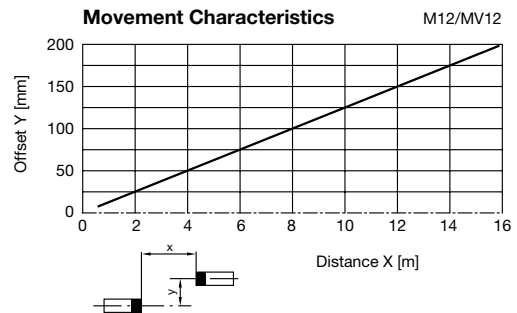
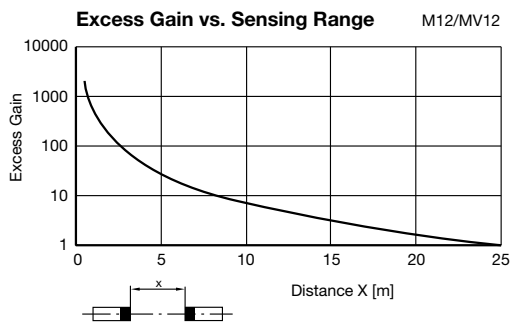

Sensing Characteristics

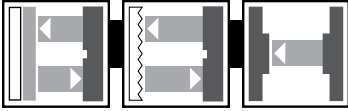



Series Specifications

MLV12 Series Specifications

VOLTAGE DROP	≤ 2.5 VDC
SHORT CIRCUIT AND OVERLOAD PROTECTION	Yes
REVERSE POLARITY PROTECTION	Yes
VOLTAGE RIPPLE	10%
LED(s)	Yes (2)*
OPERATING MODE	Light on/dark on
STANDARDS	EN 60947-5-2
PROTECTION (IEC)	IP67
HOUSING MATERIAL	Nickel-plated die-cast zinc and glass-fiber reinforced plastic PC
LENS	Plastic
WEIGHT	2.1 oz (per housing)
APPROVALS	  

*See MLV12 Series Sensitivity Adjustment for LED functions.

4-in-1 Output

The 4-in-1 output automatically detects the connected load, so the output either sources or sinks current depending on the load. The light on/dark on switch on the housing selects normally open or normally closed mode. A single sensor can operate as NPN normally open, NPN normally closed, PNP normally open, or PNP normally closed.



Wiring Diagrams

DC



Cable Connection

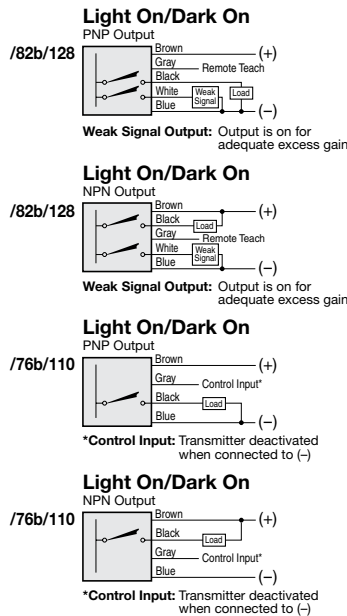
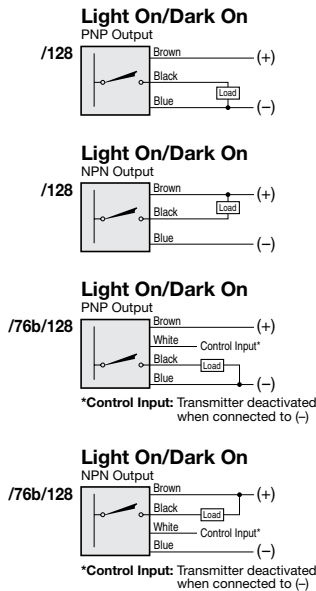

Transmitter (thru-beam models)

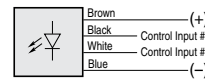

Control Input #1: Transmitters deactivated when connected to (-)

Control Input #2: 1 of 2 transmitters deactivated when connected to (+) for reduced sensing range

Wiring diagrams continued on next page

Wiring Diagrams (cont.)

DC



Quick Disconnect

Note: Wiring diagrams show quick disconnect pin numbers.

V15 Type

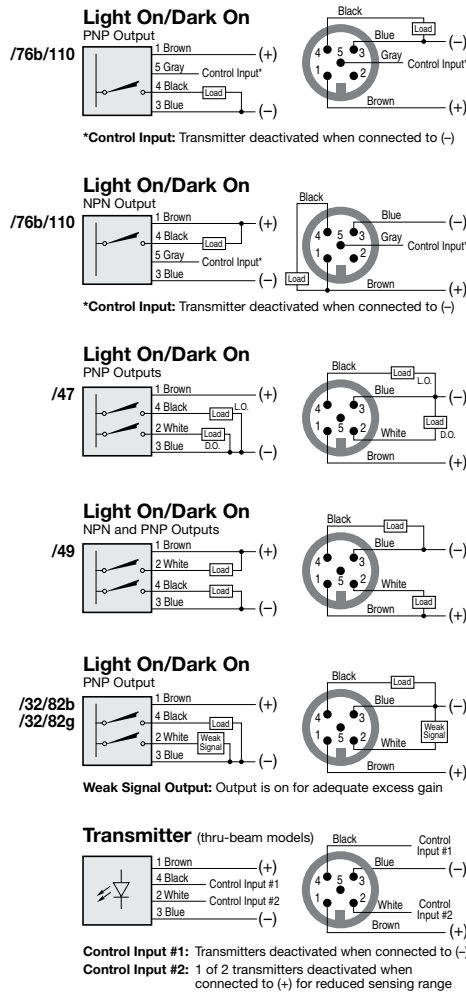
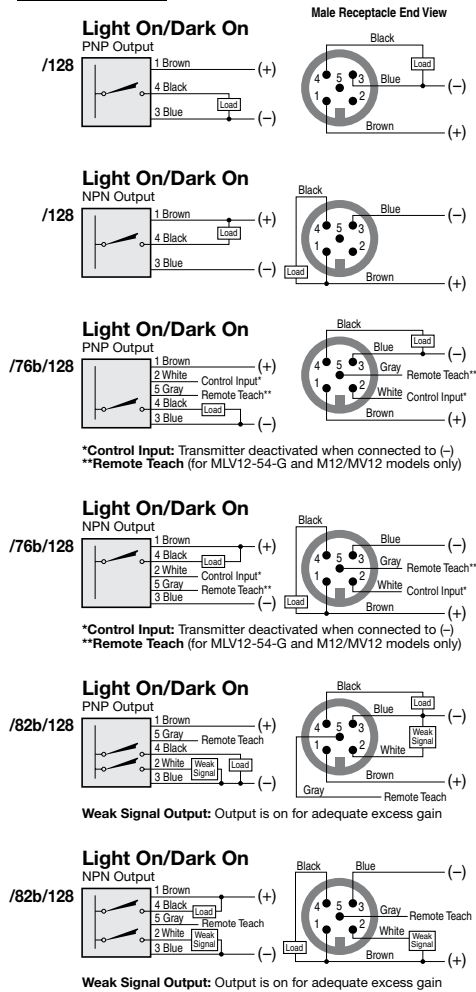

MLV12 Series Sensitivity Adjustment

Dura-Vue MLV12 photoelectric sensors are available with two different configurations for sensitivity adjustment. The first type is for the MLV12-8-HW background evaluation, MLV12-8-H background suppression, and the MLV12-54 polarized retro-reflective models. The second is for the MLV12-54-G clear object sensing models and the M12/MV12 thru-beam models.

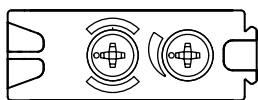

Configuration 1
(MLV12-8 and MLV12-54)

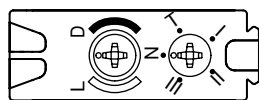

Configuration 2
(MLV12-54-G and M12/MV12)

The adjustments for the MLV12-8 and MLV12-54 models include two potentiometers. The one closest to the lens allows selection of light on or dark on operating mode. This potentiometer can be turned in either direction. The other potentiometer is the sensitivity adjustment and can be turned toward the larger end of the marked swirl to increase sensing range or toward the shorter end of the swirl to decrease sensing range.

The adjustments for the MLV12-54-G and M12/MV12 models also include two potentiometers. Both can be turned in either direction (clockwise or counter-clockwise). The one closest to the lens again allows selection of light on or dark on operating mode. The other potentiometer has 5 settings: N, T, I, II, and III.

To program MLV12-54-G or M12/MV12:

- Align the powered MLV12-54-G to its reflector or align the powered thru-beam pair M12/MV12.
- Turn the potentiometer from N to T and wait approximately 1 second until the yellow LED flashes (1.5Hz).
- (a.) If programming by potentiometer is desired, turn the potentiometer to either I, II, or III depending on the contrast desired. (Refer to "Modes Selected by Potentiometer" chart.)
 (b.) If programming by external teach is desired, apply a pulse (V+ of supply voltage) to the external teach input of the sensor. The pulse duration should correspond to the contrast desired. (Refer to "Modes Selected by External Teach Input" chart.)

After a successful teach, settings will be stored even if power to the sensor is disconnected. Detection of low-contrast transparent objects is affected by excessive lens contamination.

Models with weak signal (/82) outputs have an additional output to notify when the reflected light is barely adequate. This could be caused by poor alignment, contaminants on the lens, or excessive sensing range. This output will be ON for good conditions and will turn OFF for marginal excess gain.

LED Diagnostics

Green LED	Yellow LED	Indicates
ON solid	—	Power ON
Flashing (0.8Hz)	OFF	Under-voltage
Flashing (4Hz)	OFF	Short-circuited output
Flashing (1.5Hz)	Flashing (1.5Hz)	Teach mode initiated
ON solid	Flashing (4Hz)	Marginal excess gain
ON solid	ON solid	Light is received

Modes Selected by Potentiometer

Position	Mode
N	Normal mode – for detection of opaque objects
T	Teach mode
I	15% contrast (most sensitive to transparent targets)
II	25% contrast
III	40% contrast

Modes Selected by External Teach Input

V+ Pulse Width (ms)	Mode
50 (30-100)	I (15% contrast)
150 (100-200)	II (25% contrast)
>200	III (40% contrast)

Dimensions (mm)

MLV12..., M12..., MV12...

