

SWT30 Specifications

NEMIC-LAMBDA

*:For delivery, contact to our sales office.

CA701-01-01C

ITEMS	MODEL	SWT30-522			SWT30-525			SWT30-5FF			
		CH1	CH2	CH3	CH1	CH2	CH3	CH1	CH2	CH3	
1	Nominal Output Voltage	V	+5	+12	-12	+5	+12	-5	+5	+15	-15
2	Minimum Output Current	A	0.2	0.4	0	0.2	0.4	0	0.2	0.4	0
3	Maximum Output Current	A	2	1.5	0.3	2	1.5	0.3	2	1	0.3
4	Peak Output Current (*10)	A	3	3	-	3	3	-	3	2.2	-
5	Maximum Output Power (Peak)	W	31.6 (49.6)			29.5 (47.5)			29.5 (47.5)		
6	Efficiency (Typ) (*1)	-	70%								
7	Input Voltage Range (*2)	-	85 - 265VAC(Continuously), 47 - 63Hz / 110 - 340VDC								
8	Input Current (Typ) (*1)	-	0.9A (Vin=100VAC) / 0.45A (Vin=200VAC)								
9	Inrush Current(Typ)	-	15A / 100VAC, 30A / 200VAC (cold start Ta=25°C)								
10	Output Voltage	-	CH1 (+5V) Fixed, CH2,3 Fixed Shipment condition : CH1:±1%, CH2(+12V) :±3%, CH2(+15V) :±5%, CH3 :±5%								
11	Maximum Ripple & Noise (*3)	-	±5V:120mV, ±12V:150mV, ±15V:150mV								
12	Maximum Line Regulation (*3,4)	-	CH 1: 1%, CH2 : 2%, CH3 : 1%								
13	Maximum Load Regulation (*3,5)	-	CH 1: 2%, CH2 : 4%, CH3 : 2%								
14	Maximum Temperature Drift (*3,6)	-	0.04% / °C								
15	Over Current Protection (*7)	-	Automatic recovery, O.C.P point : 170% -								
16	Over Voltage Protection (*8)	-	6V - (CH1 only)								
17	Hold-up Time (Typ) (*1)	-	17ms (Input 100VAC)								
18	Operating Temperature (*9)	-	Convection cooling 0 - +50°C : 100% load, +60°C : 70% load								
19	Operating Humidity	-	30 - 90%RH (No dewdrop)								
20	Storage Temperature	-	-20 - +85°C								
21	Storage Humidity	-	10 - 95%RH (No dewdrop)								
22	Cooling	-	Convection Cooling								
23	Withstand Voltage	-	Input - Output : 3kVAC (20mA), Input - FG : 2.5kVAC (20mA) Output - FG : 500VAC (100mA) for 1min								
24	Isolation Resistance	-	More than 100MΩ at 25°C and 70%RH , Output - FG : 500VDC								
25	Vibration	-	10 - 55Hz Amplitude (Sweep for 1min). Less than 2G, X,Y,Z 1hour each.								
26	Shock	-	Less than 20G								
27	Output Grounding	-	All channels common ground (2 terminals)								
28	Safety	UL1950	Approved								
		CSA950	Approved								
		EN60950	Approved								
		DENTORI	Built to meet								
29	EMI	-	Built to meet EN55011-B,EN55022-B, FCC-ClassB, VCCI-2.								
30	Radiated Emission	-	Built to meet EN55011-B,EN55022-B, FCC-ClassB, VCCI-2.								
31	Weight	g	230								
32	Size (WxHxD)	mm	76.2 x 127 x 30.5 (Refer to Outline Drawing)								
		inch	3.00 x 5.00 x 1.20(2.55 x 4.55 mounting hole Ø3.5mm)								

*Read instruction manual carefully, before using the power supply unit.

=NOTES=

- *1. At 100VAC/ 200VAC and Maximum. Output power (Convection cooling), Ta=25°C.
- *2. For cases where conformance to various safety specs (UL,CSA, EN) are required to be described as 100-120VAC, 200-240VAC, 50/60 Hz on name plate.
- *3. Please refer to Fig A for measurement determination of line & load regulation and output ripple voltage.
- *4. From 85 - 132VAC / 170 - 265VAC, constant load.
- *5. From Min. load - Full load (Maximum power), constant input voltage.
- *6. From 0°C - +50°C, constant input voltage and load.
- *7. Current limiting with automatic recovery. Avoid to operate over load or dead short for more than 30 seconds.
- *8. Over voltage clamping by zener diode.
- *9. At standard mounting method, Fig B.
- *10. Peak current operation is less than 10 sec. with duty factor less than 30%.
In addition, it does not has to satisfy the total regulation specification.

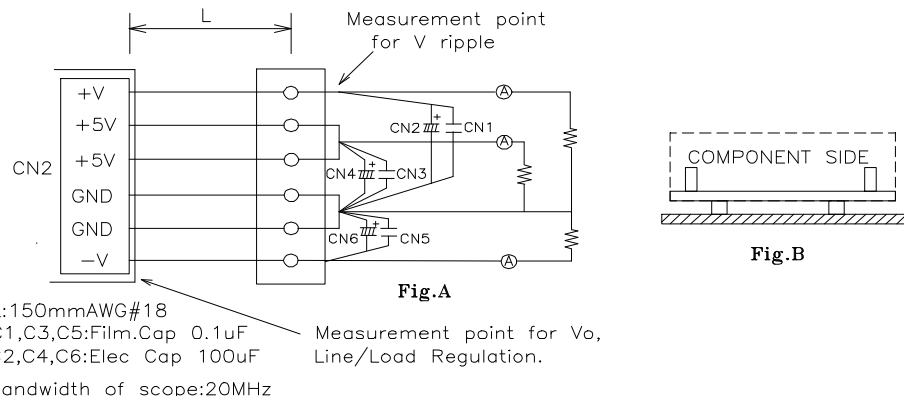

SWT 30 OUTPUT DERATING

NEMIC-LAMBDA

CA701-01-03A

Ta (°C)	LOAD(%)				
	MOUNTING : A	MOUNTING : B	MOUNTING : C	MOUNTING : D	MOUNTING : E
0	100	100	100	100	100
20	100	100	100	100	100
40	100	100	100	100	100
50	100	75	100	75	75
60	70	50	70	50	50

OUTPUT DERATING CURVE

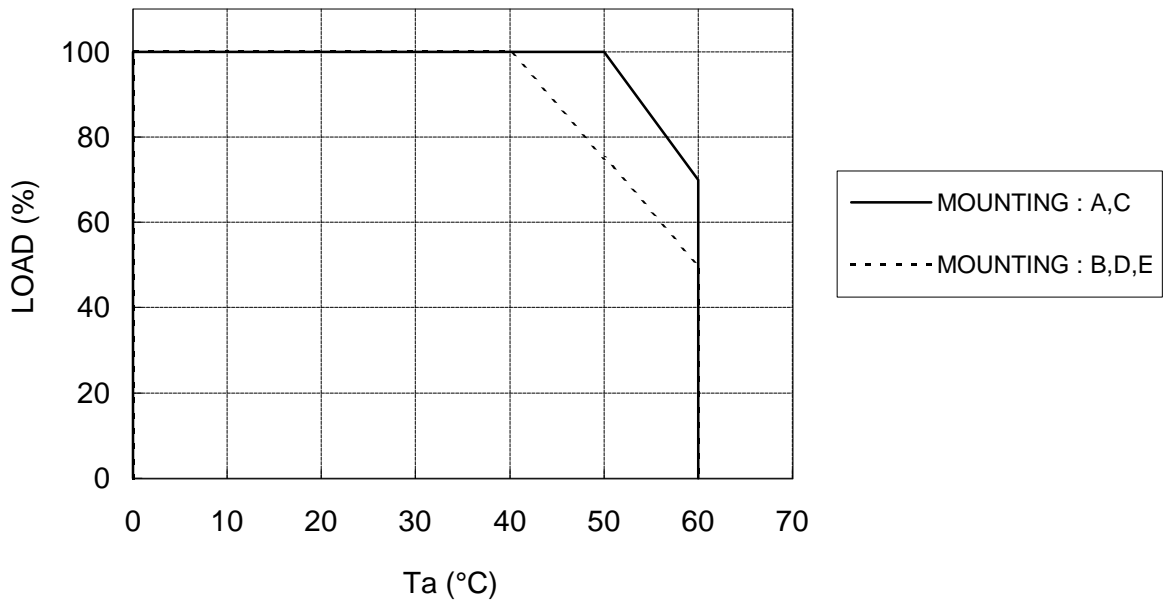

- MOUNTING : A
- MOUNTING : B
- MOUNTING : C
- MOUNTING : D
- MOUNTING : E
- DONT USE

(STANDARD MOUNTING)

