

NV175 Series



3" x 5" 175-200W Power Supplies

- ◆ 1-5 Outputs
- ◆ Up to 90% Efficient
- ◆ Active Power Factor Correction
- ◆ Universal Input (90 - 264VAC)
- ◆ No Minimum Loads
- ◆ Medical Approvals (Basic Insulation Input-Output)

RoHS

Key Market Segments & Applications

Broadcast	Test & Measurement
Medical	Industrial Computing and Routers

Features and Benefits

Feature	Benefit
◆ High Efficiency	◆ Less heat dissipated in system
◆ Low Profile	◆ Fits in 1U enclosures
◆ Power Factor Corrected	◆ Supports Global Use
◆ No Minimum Loads	◆ Ease of Use

Specifications

MODEL		NV175
ITEMS		
Input Voltage range	-	90 - 264VAC (47 - 63Hz, 440Hz with reduced PFC)
Inrush Current	A	<40A at 25°C and 264VAC input, Cold Start
Power Factor Harmonics	-	EN61000-3-2 Compliant (0.97 typical)
Regulation Total	-	1%; Including Line (for 90-264VAC input change), Load (for 0-100% load change) and Cross (for 0-100% load change on any other output) regulation
Ripple & Noise	mV	1% or 50mV (Which ever is greater)
Efficiency	-	Up to 90%, configuration dependant
Minimum Load	A	None
Overcurrent Protection	-	>105%
Overvoltage Protection	V	CH1 & CH2, 120-130%, Cycle AC line to reset
Overtemperature Protection	-	Yes
Hold Up Time (Typ)	ms	>16ms at 90VAC Input
Leakage Current (max)	µA	123µA 120VAC 60Hz, 257µA 240VAC 60Hz, <300µA 264VAC 63Hz (Type Test results)
Remote Sense	-	On Outputs CH1 & CH2, 0.5V compensation maximum
DC Good	-	CH1 Only, High on Fail (90% of nominal ±5%)
Remote On/Off (Specify N option)	-	-N1 or -N2 option: TTL level high = Off, -N3 or -N4 option: open circuit = Off (except standby)
Operating Temperature (1)(7)	-	0 to +70°C. Derate linearly to 50% load from 50°C to 70°C
Storage Temperature	-	-40 to +85°C
Humidity (non condensing)	-	5 - 95% RH
Cooling	-	Forced air, 2m/s from input to output
Isolation (4)	-	Input to Ground 2.3kVDC, Input to Output 4.3kVDC, Output to Ground 200VDC
Vibration (non operating)	-	Conforms to MIL-STD-810E, Method 516.5, Pro I, IV, VI; EN60068-2-6, IEC68-2-6
Shock	-	Conforms to MIL-STD-810E/F, Method 514.4, Pro I, Cat 1,9; EN60068-2-27, EN60068-2-47, IEC68-2-47, IEC68-2-47, JIS C0041-1987
Safety Agency Approvals	-	UL60950-1, CSA22.2 No 60950-1, EN60950-1, IEC60950-1, CE for LVD, IEC60601-1, EN60601-1, EN61010-1, IEC61010-1
Immunity	-	EN61000-6-2:2001, EN61000-4-2, -3, -4, -5, -6, -8, -11
Conducted Emissions and Flicker	-	EN55022 Class B (per CISPR.22), EN61000-3-3
Radiated Emissions (2)	-	EN55022 Class A (per CISPR.22)
Weight (Typ)	g	250g
Size (without cover) (3)	in	3" x 5" x 1.25"; N option version 3.7" x 5" x 1.25"
Warranty	yrs	Three Years

(1) -20°C cold start

(4) Input-Output: Reinforced IEC60950-1, Basic IEC 60601-1.

(2) See application note for Class B

See NV175-M for reinforced medical insulation

(3) Including underside component leads

NV175 Series

Stocked Models Quick Selector

Model	CH1 (5)	CH2 (5)	CH3	CH4	CH5 Stand By (6)	Global Option Type
NV1-1T000	12V/15A	-	-	-	-	-
NV1-1G000	24V/7.5A	-	-	-	-	-
NV1-453TT	+5V/25A	+3.3V/15A	+12V/5A	-12V/1A	-	-
NV1-453FF	+5V/25A	+3.3V/15A	+15V/5A	-15V/1A	-	-
NV1-4G5TT	+24V/7.5A	+5V/8A	+12V/5A	-12V/1A	-	-
NV1-4G5FF	+24V/7.5A	+5V/8A	+15V/5A	-15V/1A	-	-
NV1-453TT-N3	+5V/25A	+3.3V/15A	+12V/5A	-12V/1A	5V/2A	N3 (ATX)
NV1-453FF-N3	+5V/25A	+3.3V/15A	+15V/5A	-15V/1A	5V/2A	N3 (ATX)
NV1-4G5TT-N3	+24V/7.5A	+5V/8A	+12V/5A	-12V/1A	5V/2A	N3 (ATX)
NV1-4G5FF-N3	+24V/7.5A	+5V/8A	+15V/5A	-15V/1A	5V/2A	N3 (ATX)

Notes:
 (5) Maximum combined current from CH1 + CH2 = 25A
 5V CH1 models are limited to 175W max. All others 180W, 200Wpk 5 mins
 (6) CH5 is always on regardless of inhibit status. Peak rated at 2.5A, floating output
 (7) Convection cooled maximum ratings: CH1: 55W, Ch2: 8.25W, Ch3: 9W, CH4: 3W, 75.25W total. 0°C - 40°C temperature range
 (8) 12 - 12.5V if 24V CH3 is fitted.
 (9) 14.5 - 15.5V if 24V CH3 is fitted.
 (10) 24 - 24.5V if 5V CH2 is fitted.
 24 - 26V if 24V CH3 is fitted

Outline Drawing

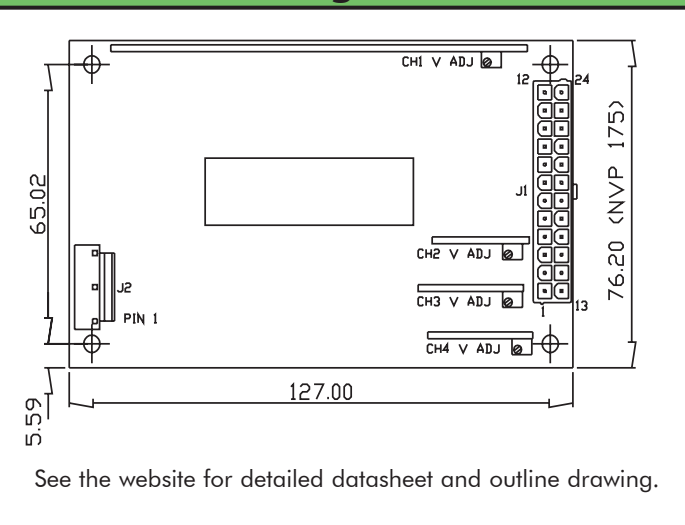

Built to Order Model Selector

CH1	CH1(5) Adjust. Code	CH1(5) Adjust. Range	CH2(5)	CH2 Code	Adjust. Range	CH3	CH3 Code	Adjust. Range	CH4	CH4 Code	Adjust. Range
+5V / 25A	5	5 - 5.5V	+1.8V / 15A +2.7V / 15A +3.3V / 15A No output	1 2 3 0	0.9 - 3.3V 2.5 - 3.3V 2.5 - 3.3V -	+12V / 5A +15V / 5A +24V / 2.5A No output	T F G 0	12 - 15V 12 - 15V 18 - 24V -	-12V / 1A -15V / 1A -3.3V / 2A -5V / 2A -12V / 2A -15V / 2A Fan Supply only No output	T F 3H 5H TH FH 0H 0	Fixed Fixed Fixed Fixed Fixed Fixed Fixed
+12V / 15A +15V / 12A	T F	12 - 15V (7) 12 - 15V (8)	+5V / 10A No output	5 0	3.3 - 5.5V -						
+24V / 7.5A	G	24 - 28V (9)	+5V / 8A No output	5 0	3.3 - 5.5V -				Add "P" to code for positive polarity output	Add "P" to code for positive polarity output	

How to Create a Model Number

NV1-	Enter number of outputs	CH1 Code	CH2 Code	CH3 Code	CH4 Code	Global Option	Case Option
------	-------------------------	----------	----------	----------	----------	---------------	-------------

No Option	Blank	Blank	No Case
AC Fail, Remote On/Off, 5V/2A Standby, CH1 DC Good	N	U	U Chassis
AC Fail, Remote On/Off, 13.5V/1A Standby, CH1 DC Good	N2	C	U Chassis with Cover
ATX AC Fail+Remote On/Off, 5V/2A Standby, CH1 DC Good	N3	F	U Chassis, Cover and Fan*
ATX AC Fail+Remote On/Off, 12V/1A Standby, CH1 DC Good	N4	I	U Chassis, Cover and Fan* and IEC inlet

* A high output CH4 (3H, 5H, TH, FH) or fan supply 0H must be selected to provide fan option.

Example

NV1 3 G 5 0 3HP N C

Description: Triple output, 24V/7.5A, 5V/8A, 3.3V/2A, Global option N, U Chassis with cover.

Mating Parts (Molex)

CONN	Housing	Pins
J1	39-01-2245	44476-3112
J2	09-50-8051	08-52-0113

Other Lambda Industrial Products

NV	300 to 700W Medical, 1-6 outputs
SC40/60	40 to 80W single, dual & triple 3x5 footprint
ZWS/ZWSPAF	5 to 240W single output power supplies