



EAC RECEPTACLES SERIES EAC

1. EAC227

- 2. EAC311**
- 3. EAC305**
- 4. EAC323**
- 5. EAC309**
- 6. EAC325**
- 7. EAC333**
- 8. EAC333S**

[click here to download a schematic drawing](#)

(you will need to have Adobe Acrobat installed on your system to do this)

[click here to download a schematic drawing](#)

(you will need to have Adobe Acrobat installed on your system to do this)

[click here to download a schematic drawing](#)

(you will need to have Adobe Acrobat installed on your system to do this)

[click here to download a schematic drawing](#)

(you will need to have Adobe Acrobat installed on your system to do this)

[click here to download a schematic drawing](#)

(you will need to have Adobe Acrobat installed on your system to do this)

[click here to download a schematic drawing](#)

(you will need to have Adobe Acrobat installed on your system to do this)

[click here to download a schematic drawing](#)

(you will need to have Adobe Acrobat installed on your system to do this)



Two and three-pin/contact grounding primary power receptacles are designed to meet EN 60 320, as well as applicable UL, CSA, VDE and other specifications. Receptacles feature choice of short, standard or long solder lugs or FASTON[®] terminals. Receptacles snap-in or screw mount from the front or rear of panel. Receptacles have orbitally riveted lugs (except EAC233, EAC305, EAC323 EAC325, EAC333, EAC405) for superior mechanical/

electrical connections. Extended socket versions permit minimum behind-panel depth.

Receptacles are designed for use in European and domestic instrumentation, power rack mounted devices, test equipment and appliances. Three-pin male receptacles have .125 inch (3.18 mm) longer center (ground) pin. Ground circuit is established before power circuits "make", and is maintained until after power circuits "break".



EAC405

SPECIFICATIONS

ELECTRICAL

Insulation Resistance: 2 million megohms @ 500 V DC.

Dielectric Strength: 1500 V (rms).

Arcing Test: Meets UL 498 Standard.

MECHANICAL

Solderability Standard: Meets MIL-STD-202, method 208, EIA RS-186-9E.

ENVIRONMENTAL

Thermal Range: -55° C to +65° C (except EAC45x series).

Salt Spray: Meets MIL-STD-202, method 101; EIA-RS-186-5E, method 5.

MATERIAL

Shell: EAC307 through EAC327. Black polyester. EAC303, EAC307 through EAC315. UL flammability rating of UL94 V-0, yellow card #E45575.

EAC309 through EAC327, EAC333. Black polyester, UL flammability rating of UL94 V-0, yellow card #E45575.

EAC233, EAC233S, EAC305, EAC325, and EAC333S. Black polycarbonate, UL flammability rating of UL94 V-0, yellow card #E45329.

EAC323, EAC409 through EAC411 Black polycarbonate, UL flammability rating, or equivalent UL94 V-0, yellow card #E33640, or equivalent.

Pins, Contacts and Terminals: Plated copper alloy.

☒**EAC227**--2-pin male receptacle with standard solder lug terminals, similar to EAC327.

☒**EAC233**--2-pin, male receptacle with right-angle housing for PC mount. PC terminals project .130 inch (3.3 mm) to extend through PC board. Rear of panel mount. Two, .136 inch (3.45 mm) diameter holes permit fastening to PC board; two additional .136 inch (3.45 mm) holes are for fastening to panel or chassis, if required.

☒**EAC233S**--Similar to EAC233, but with two, snap-in retainers through mounting flanges for PC mount.

EAC305--3-contact female receptacle. Front mount with two, #4 screws or .094 inch (2.38 mm) diameter rivets

(not supplied).

EAC309--3-pin male receptacle with standard lug terminals. Mounts from front or rear of panel with two, #5 screws or .125 inch (3.18 mm) diameter rivets (not supplied).

EAC311--3-pin male receptacle with FASTON[®] terminals. Mounts from front or rear of panel with two, #5 screws or .125 inch (3.18 mm) diameter rivets (not supplied).

☒**EAC315**--3-pin male receptacle with long solder lug terminals. Mounts from front or rear of panel with two, #5 screws or .125 inch (3.18 mm) diameter rivets (not supplied).

☒**EAC319**--3-pin male receptacle with short solder lug terminals. Mounts from front or rear of panel with two, #5 screws or .125 inch (3.18 mm) diameter rivets (not supplied).

☒**EAC323**--3-pin male receptacle with short solder lug terminals. Extended socket housing (mounting flange on rear of receptacle) provides more behind panel clearance. Mounts with two, #4 screws or .094 inch (2.38 mm) diameter rivets (not supplied).

EAC325--3-contact female receptacle with short solder lug terminals. Extended housing (mounting flange on rear of receptacle) provides more behind panel depth. Mounts with two, #4 screws or .094 inch (2.38 mm) diameter rivets (not supplied).

EAC327--3-pin male receptacle, similar to EAC319 except with standard solder lugs.

EAC333--3-pin, 10A, 250V male receptacle with right-angle housing for PC mount. PC terminal and hole mounting details are the same as for EAC233. Ground pin is integral with ground solder lug on rear of receptacle.

☒**EAC333S**--Similar to EAC333, but with two, snap-in retainers through mounting flanges for PC mount.

☒**EAC405**--3-contact female receptacle with standard solder lug terminals. Snap-in panel mounting.

EAC409--3-pin male receptacle with standard solder lug terminals. Snap-in panel mounting.

EAC233S	M	Rear	PC	UL, CSA,	15 A, 250 V AC	P2392	Semko, Demko, Nemko, SETI, and SEV Approved
				VDE	10 A, 250 V AC		
EAC305	F	Front	Solder Lug	UL & VDE	15 A, 250 V AC	-	Semko, and SEV Approved
				VDE	10 A, 250 V AC		
EAC309	M	Front or Rear	Solder Lug	UL & CSA	15 A, 250 V AC	P2392	Demko, Semko, Nemko, SETI, and SEV Approved
				VDE	10 A, 250 V AC		
EAC311	M	Front or Rear	FASTON	UL & CSA	15 A, 250 V AC	P2392	Semko, Demko, Nemko, SETI, and SEV Approved
				VDE	10 A, 250 V AC		
EAC315	M	Front or Rear	Solder Lug (Long)	UL & CSA	15 A, 250 V AC	P2392	Semko, Demko, Nemko, SETI, and SEV Approved
				VDE	10 A, 250 V AC		
EAC319	M	Front or Rear	Solder Lug (Short)	UL & CSA	15 A, 250 V AC	P2392	-

				VDE			
EAC323	M	Front or Rear	Solder Lug (Short)	UL & CSA	15 A, 250 V AC	P2392	Mounting flange on rear Semko, Nemko, SETI Approved
				VDE	10 A, 250 V AC		
EAC325	F	Rear	Solder Lug (Short)	UL & CSA	15 A, 250 V AC	-	Mounting flange on rear
				VDE	10 A, 250 V AC		
EAC327	M	Front or Rear	Solder Lug	UL & CSA	15 A, 250 V AC	P2392	Demko, Semko, Nemko SETI and SEV Approved
				VDE	10 A, 250 V AC		
EAC333	M	Rear	PC	UL, & VDE	15 A, 250 V AC	P2392	Semko, Demko, Nemko, SETI, and SEV Approved
				CSA	10 A, 250 V AC		
EAC333S	M	Rear	PC	UL & VDE	10 A, 250 V	P2392	
				CSA			
EAC405 ⁵	F	Snap-In	Solder Lug	UL & CSA	15 A, 250 V AC	-	-

EAC RECEPTACLES

SERIES EAC

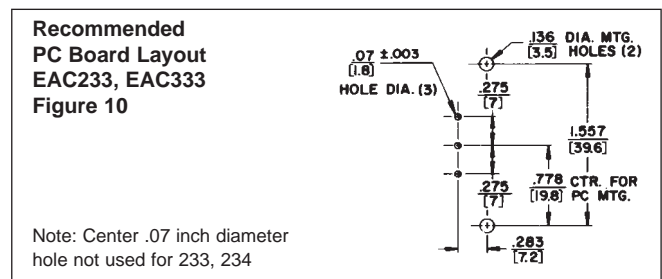
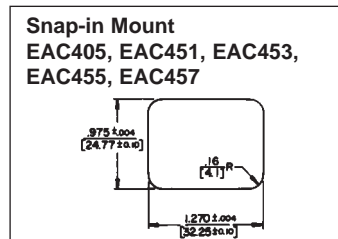
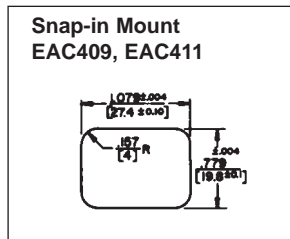
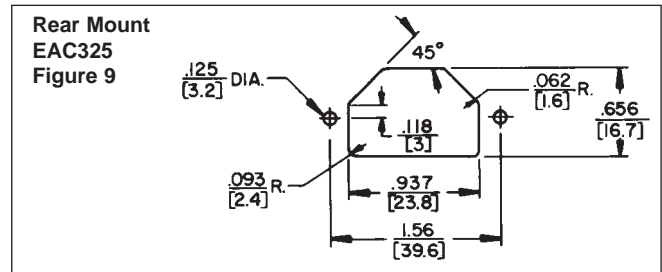
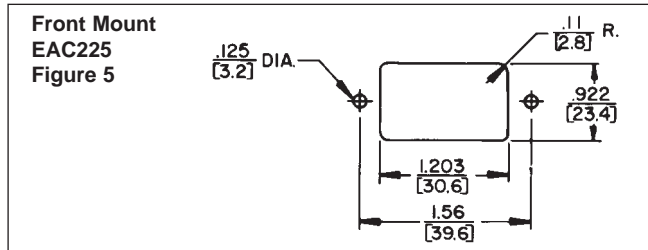
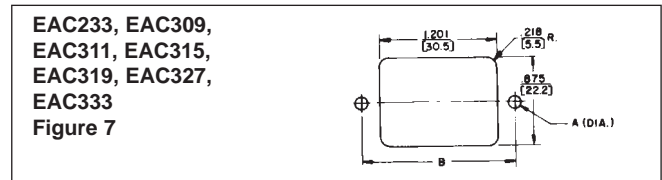
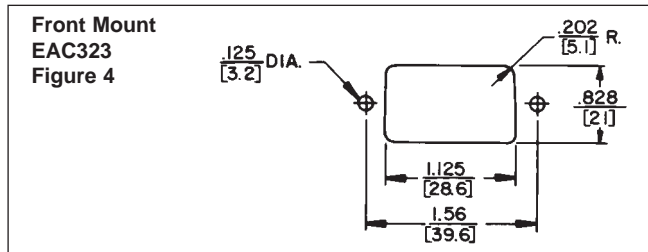
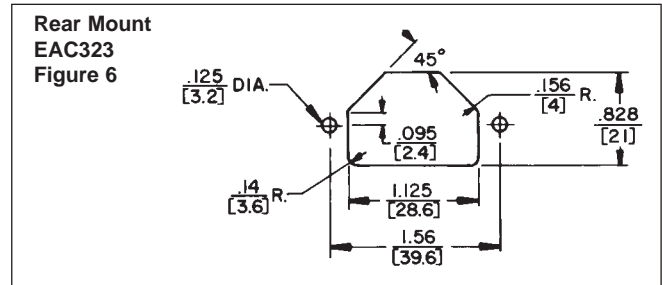
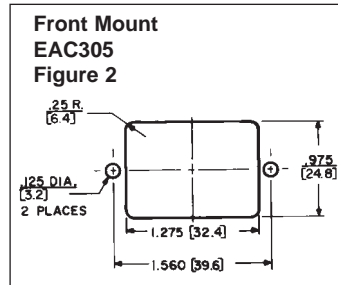
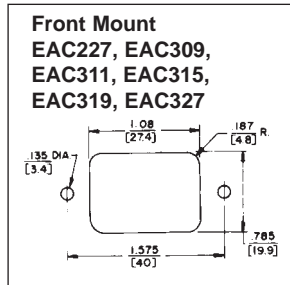

Note: Unless otherwise specified, all dimension tolerances are ± .01 inch (+0.25 mm)

DIMENSIONS ARE FOR REFERENCE ONLY Inch
(mm)

NOTE: Contact your Switchcraft Representative for price and delivery.

EAC RECEPTACLES

SERIES EAC

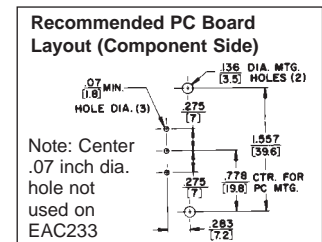
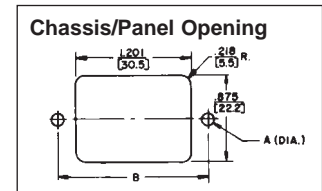
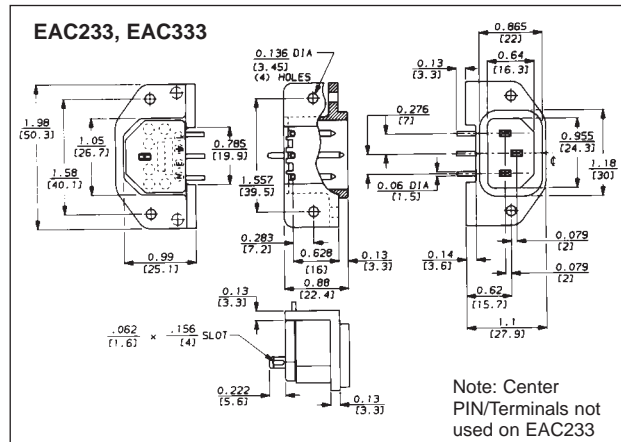
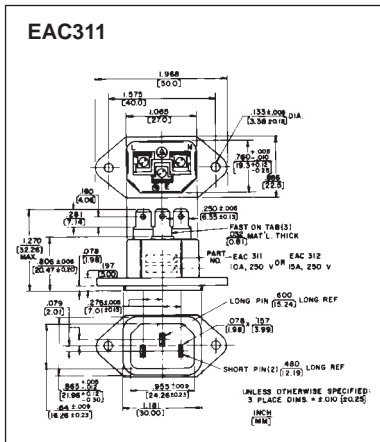
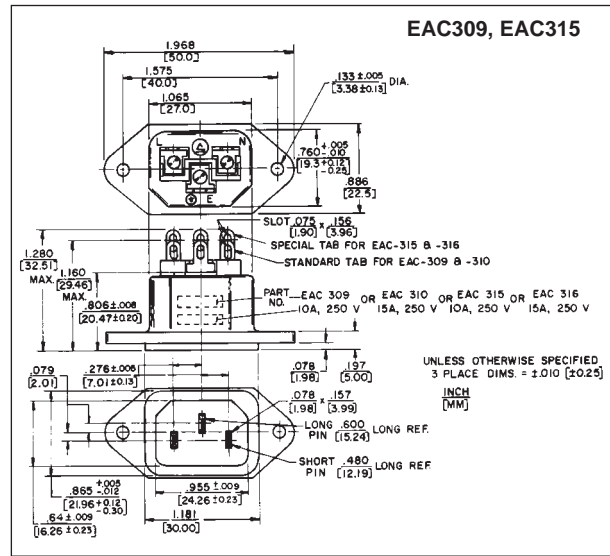
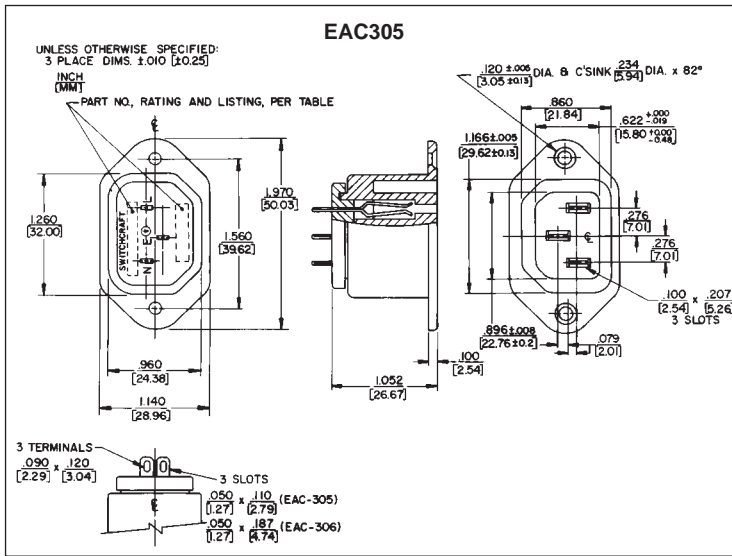
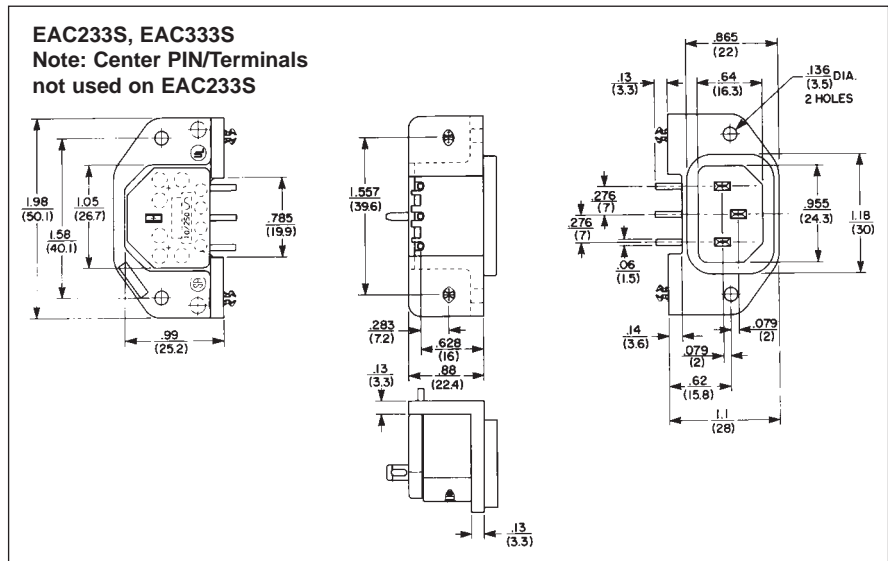
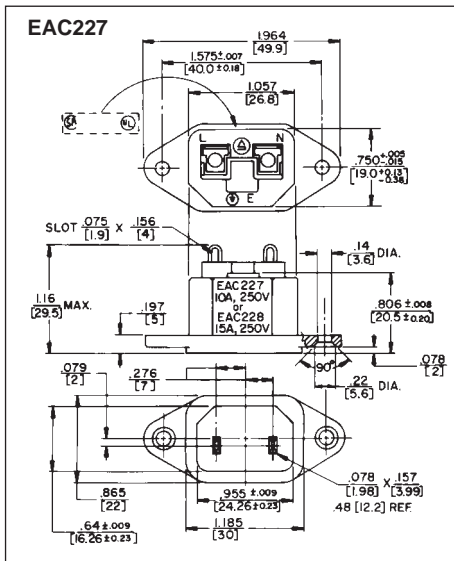

Note: Unless otherwise specified, all dimension tolerances are ±.01 inch (+0.25 mm)

DIMENSIONS ARE FOR REFERENCE ONLY
Inch (mm)

NOTE: Contact your Switchcraft Representative for price and delivery.