



S662 Preset Batch/Dual Counter



- Easily programmed from the front panel
- Remote Reset capability
- Input variety: Quadrature, Switch, TTL, CMOS, NAMUR, PNP, NPN
- Software functions include:

Password	Display Scaling
Set Point Programming	Decimal Point Selection

The S662 is a multi-function counter that can be easily configured to operate either in a dual mode or in a totalizing/batch mode, each with separate scaling and reset functions. When functioning in the dual mode, full direction control is maintained for the totalizing and batch counts. In the totalizing batch mode, the secondary value (batch count) is incremented after the primary totalizing count has completed its cycle.

The counter is powered from 120 or 240VAC and has a non-volatile EEPROM to retain all programming and count information when the power source is removed or interrupted. An option 12DCV excitation output module can provide power for external sensors.

This versatile counter has latching, boundary or timed (0.01 to 599.99 seconds) output modes.

Mounting Requirements

The S660 series 1/8 DIN counters require a panel cutout of 1.77" (45mm) high by 3.62" (92mm) wide. To install the counter into a panel cutout, remove the clips from the side of the meter. Slide the meter through your panel cutout, then slide the mounting clips back on the meter. Press evenly to ensure a proper fit.

Specifications

DISPLAY	
Type	6-digit, 7-segment, red LED
Height	0.56" (14.2mm)
Decimal Point	User-programmable
Count Direction	"+" indication implied, "-" indication displayed
Display Range	-99,999 to +999,999
Output Indicators	1 and 2
POWER REQUIREMENTS	
AC Voltages	120, 240VAC, ±10%
Power Consumption	3VA
INPUT RATINGS	
Current Sinking	10KΩ, 5% Resistor pull-up to (9.0 - 16DCV) ±10%
Current Sourcing	5.1KΩ, 5% Resistor pull-down to common
Minimum Pulse Width	~5μs
Low Pass Filter	<200Hz
Low Bias	VLT = 1.6V ±10% VUT = 3.6V ±10%
High Bias	VLT = 5.0V ±10% VUT = 7.0V ±10%
Count Rate	20KHz (Pulse Max) 5KHz (Quadrature X4 Max)
Maximum Voltage Input A, B, and User	30DCV (Max)
INPUT	
User Input	(Second channel reset) Count on the second channel is reset when the User Input is pulled low.
Standard Input	VLT ≤ 0.2DCV guaranteed low, VUT = 3.0DCV (max)
Quadrature Input	VLT ≤ 0.9DCV VUT = 3.15DCV (max)
ENVIRONMENTAL	
Operating Temp.	0°C to +40°C
Storage Temp.	-10°C to +60°C
Relative Humidity	0-80% non-condensing for temperatures less than 32°C, decreasing linearly to 50% at 40°C
Ambient Temperature	25°C
Temp. Coefficient (per °C)	±100ppm/°C
Warmup Time	15 minutes
MECHANICAL	
Bezel	3.93" x 2.04" x .52" (99.8mm x 51.8mm x 13.2mm)
Depth	3.24" (82.3mm)
Panel Cutout	3.62" x 1.77" (92mm x 45mm)
Case Material	PBT-ABS
Weight	9oz (255.1g)

Ordering Information

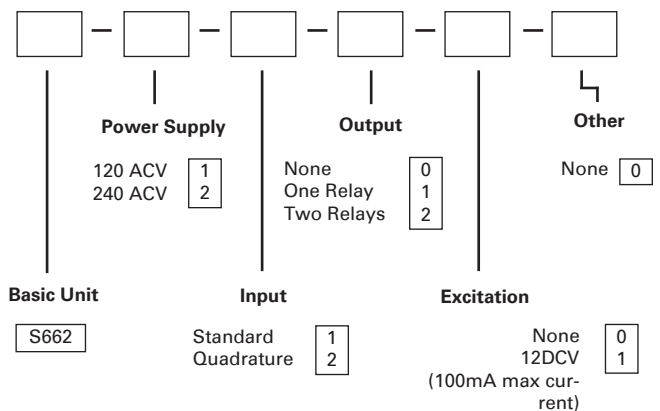

Dimensions - S660, S661, S662, S663, S664

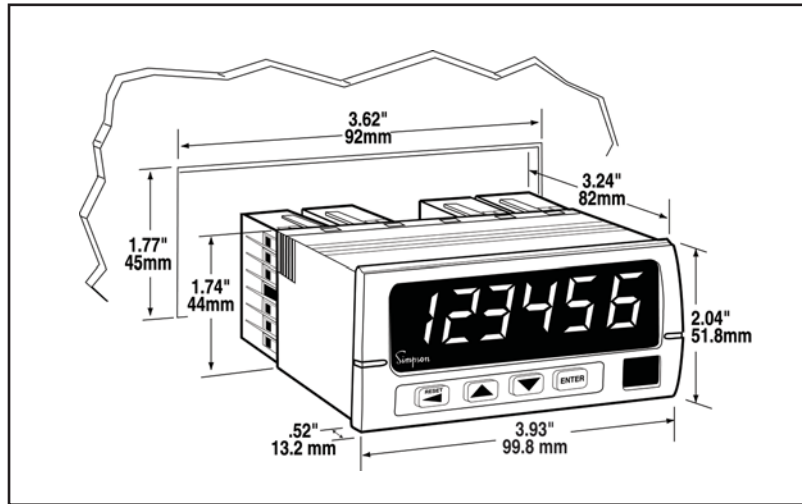

Accessories



Chariot

The Chariot is used to mount most cube-style quadrature encoders and measuring wheels. Made of anodized aluminum, the chariot includes mounting hardware and selectable pivotal points. Wheels, tires, and flexible shaft couplings are sold separately.

Catalog No. 46012



A Simpson 12" anodized aluminum measuring wheel is the right choice to complete the setup of a length measurement system. Whether the application requires one or two, Simpson's measuring wheels will perform accurately and reliably throughout the measuring process. Also included on the measuring wheel is a printed alignment scale which assists in the installation and measurement of the length measurement system. Simpson offers four replaceable durometer tires that consist of a black tire that has a longer life span and three non marking tires. The three non marking tires are for delicate materials such as plastics, textiles, wood, metal and paper to prevent tearing, damage or marking of delicate materials.



Flexible Shaft Couplings

The one-piece flexible coupling connects the shaft of a cube-style encoder to an ancillary equipment shaft without worry of misalignment of rotary frequency. The coupling ensures minimum windup, minimum rotary oscillation, and no hysteresis.

Description

Coupling: For connecting an encoder to a 3/8" shaft
Coupling package: For connecting an encoder to 1/4" or 5/16" diameter shaft*

*Package includes: One flexible coupling (1/2" I.D.) and three reducing inserts (1/4", 5/16", 3/8").

Catalog No.

46002
46003

Tire Durometer

80A, black tire; longer service life for plastics, metals
83A, non-marking tire for textiles, medium textures
92A, non-marking tire for plastics, metals, coarse wood
70A, non-marking tire for soft textiles

Catalog No.

46004
46005
46006
46007