

SPECLEADS
by Silvertronix

This drawing is not to be disclosed to a third party without the authority from the company ©

Date	8-28-09	DRN BY	MEA	TITLE	CROC CLIP COPPER	ISSUE NO.	0	PART NO.	501995C
MAT'L	COPPER	SCALE	NONE	CURRENT RATING:	10 AMP	1	9-6-09	PROJ. NO.	

FEDERAL SPEC : CID AA59466-010

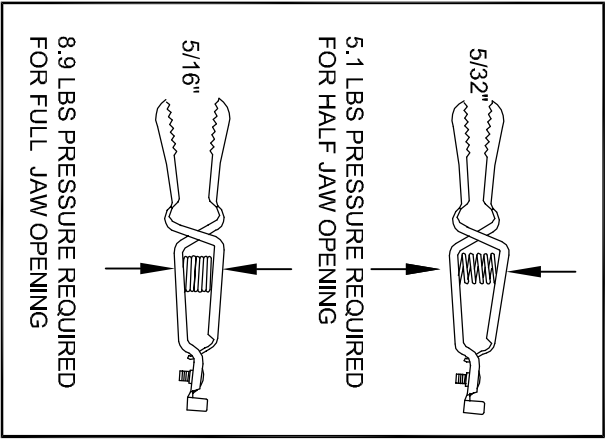

SPRING TESTED PER FED. SPEC. #WC440B FORCE APPLIED ON THE CENTER OF SPRING AXIS

FINISH: NONE

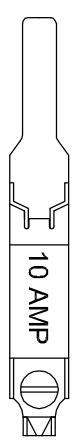
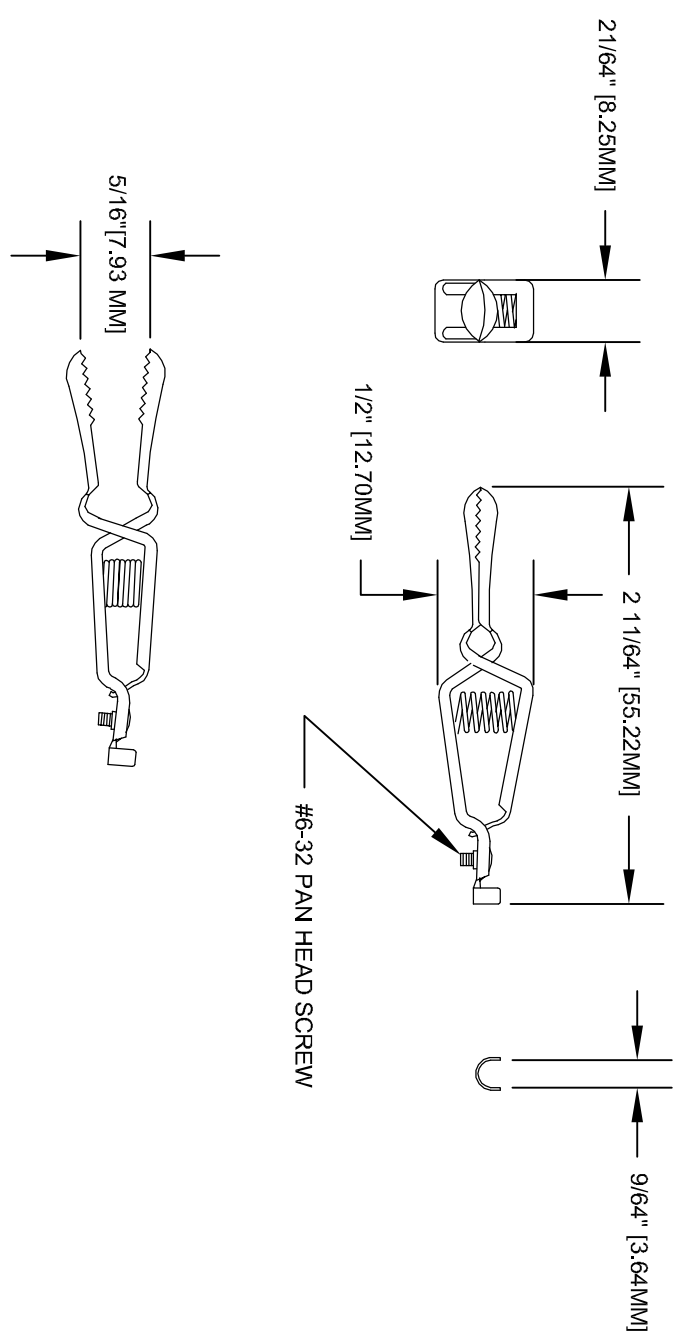

ASSEMBLY NO.

PACKAGING :

PRINTING AS ILLUSTRATED

CONCENTRICITY:

ANGLES