



SLSD-71N4

Solderable Planar Photodiode

Features

- Visible to IR spectral irradiance range
- High reliability
- Oxide passivation
- Low capacitance, high speed
- Protective coating

Description

The Silonex series of silicon solderable planar photodiodes feature low cost, high reliability, and linear short circuit current over a wide range of illumination. These devices are widely used for light sensing and power generation because of their stability and high efficiency. They are particularly suited to power conversion applications due to their low internal impedance, relatively high shunt impedance, and stability. The photodiodes have a protective coating that protects them from humidity effects.

Absolute Maximum Ratings

Storage Temperature -40°C to +105°C
 Operating Temperature -40°C to +105°C

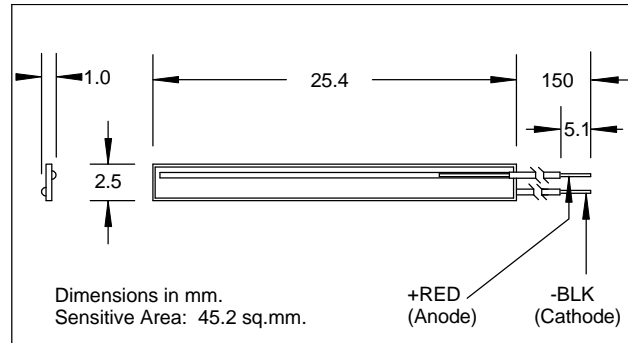

Also available without leads as part number SLCD-61N4

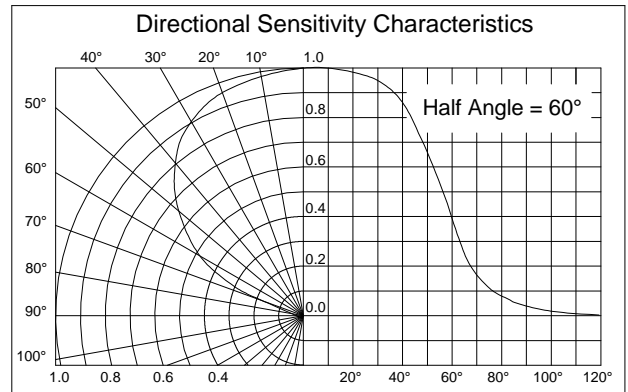

Electrical Characteristics (T_A=25°C unless otherwise noted)

Symbol	Parameter	Min	Typ	Max	Units	Test Conditions
I _{SC}	Short Circuit Current	1.4	2.3		mA	V _R =0V, E _e =25mW/cm ² (1)
V _{OC}	Open Circuit Voltage		0.40		V	E _e =25mw/cm ² (1)
I _D	Reverse Dark Current			5	μA	V _R =5V, E _e =0
C _J	Junction Capacitance		1.5		nF	V _R =0V, E _e =0, f=1MHz
S _λ	Spectral Sensitivity		0.55		A/W	λ=940nm
V _{BR}	Reverse Breakdown Voltage	20			V	I _R =100μA
λ _P	Maximum Sensitivity Wavelength		930		nm	
λ _R	Sensitivity Spectral Range	400		1100	nm	
θ _{1/2}	Acceptance Half Angle		60		deg	(off center-line)

Notes: (1) E_e = light source @ 2854 °K

Specifications subject to change without notice