

## AD590: Two Terminal IC Temperature Transducer

### Product Description

The AD590 is a two-terminal integrated circuit temperature transducer that produces an output current proportional to absolute temperature. For supply voltages between 4 V and 30 V the device acts as a high impedance, constant current regulator passing 1  $\mu\text{A}/\text{K}$ . Laser trimming of the chip's thin-film resistors is used to calibrate the device to 298.2  $\mu\text{A}$  output at 298.2K (25°C).

The AD590 should be used in any temperature sensing application below 150°C in which conventional electrical temperature sensors are currently employed. The inherent low cost of a monolithic integrated circuit combined with the elimination of support circuitry makes the AD590 an attractive alternative for many temperature measurement situations. Linearization circuitry, precision voltage amplifiers, resistance measuring circuitry and cold junction compensation are not needed in applying the AD590.

In addition to temperature measurement, applications include temperature compensation or correction of discrete components, biasing proportional to absolute temperature, flow rate measurement, level detection of fluids and anemometry. The AD590 is available in chip form making it suitable for hybrid circuits and fast temperature measurements in protected environments.

The AD590 is particularly useful in remote sensing applications. The device is insensitive to voltage drops over long lines due to its high impedance current output. Any well insulated twisted pair is sufficient for operation hundreds of feet from the receiving circuitry. The output characteristics also make the AD590 easy to multiplex: the current can be switched by a CMOS multiplexer or the supply voltage can be switched by a logic gate output.

### Features

---

- Linear current output: 1  $\mu\text{A}/\text{K}$
- Wide temperature range: -55°C to +150°C
- Probe compatible ceramic sensor package
- 2-terminal device: voltage in/current out
- Laser trimmed to  $\pm 0.5^\circ\text{C}$  calibration accuracy (AD590M)
  - Excellent linearity:  $\pm 0.3^\circ\text{C}$  over full range (AD590M)
  - Wide power supply range: 4 V to 30 V
  - Sensor isolation from case
  - Low cost

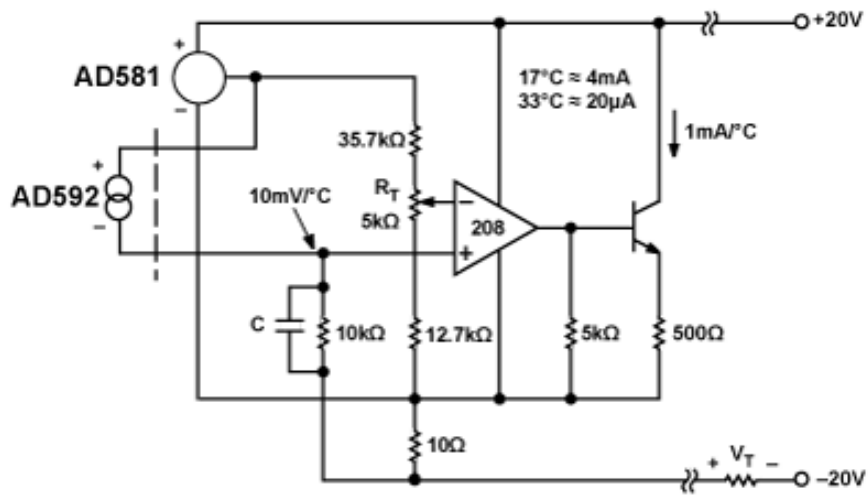

Typical Application Circuits for AD590

<a href="#">Model</a>	<a href="#">Status</a>	<a href="#">Package</a>	<a href="#">Pins</a>	<a href="#">Temp. Range</a>	<a href="#">Price* (1000 pcs.)</a>	<a href="#">Available</a>	<a href="#">ROHS Compliant</a>	<a href="#">Samples Cart</a>	<a href="#">Purchase Cart</a>
AD590JF	Prodm	<a href="#">2 ld Flat Pack</a>	2	Mil	\$10.29	08/01/2008	Y <a href="#">Material Declaration</a>	<a href="#">Contact ADI</a>	<a href="#">Add To Cart</a>
AD590JH	Prodn	<a href="#">3 ld TO-52</a>	3	Mil	\$3.82	09/19/2008	Y <a href="#">Material Declaration</a>	<a href="#">Contact ADI</a>	<a href="#">Add To Cart</a>
AD590KF	Prodn	<a href="#">2 ld Flat Pack</a>	2	Mil	\$11.15	08/01/2008	Y <a href="#">Material Declaration</a>	<a href="#">Contact ADI</a>	<a href="#">Add To Cart</a>
AD590KH	Prodn	<a href="#">3 ld TO-52</a>	3	Mil	\$5.76	09/19/2008	Y <a href="#">Material Declaration</a>	<a href="#">Contact ADI</a>	<a href="#">Add To Cart</a>
AD590LF	Prodn	<a href="#">2 ld Flat Pack</a>	2	Mil	\$24.06	08/01/2008	Y <a href="#">Material Declaration</a>	<a href="#">Contact ADI</a>	<a href="#">Add To Cart</a>
AD590LH	Prodn	<a href="#">3 ld TO-52</a>	3	Mil	\$12.84	09/12/2008	Y <a href="#">Material Declaration</a>	<a href="#">Contact ADI</a>	<a href="#">Add To Cart</a>
AD590MF	Prodn	<a href="#">2 ld Flat Pack</a>	2	Mil	\$45.55	08/01/2008	Y <a href="#">Material Declaration</a>	<a href="#">Contact ADI</a>	<a href="#">Add To Cart</a>
AD590MH	Prodn	<a href="#">3 ld TO-52</a>	3	Mil	\$27.16	09/12/2008	Y <a href="#">Material Declaration</a>	<a href="#">Contact ADI</a>	<a href="#">Add To Cart</a>

### FEATURES

**Linear current output: 1  $\mu\text{A}/\text{K}$**   
**Wide temperature range:  $-55^{\circ}\text{C}$  to  $+150^{\circ}\text{C}$**   
**Probe-compatible ceramic sensor package**  
**2-terminal device: voltage in/current out**  
**Laser trimmed to  $\pm 0.5^{\circ}\text{C}$  calibration accuracy (AD590M)**  
**Excellent linearity:  $\pm 0.3^{\circ}\text{C}$  over full range (AD590M)**  
**Wide power supply range: 4 V to 30 V**  
**Sensor isolation from case**  
**Low cost**

### GENERAL DESCRIPTION

The AD590 is a 2-terminal integrated circuit temperature transducer that produces an output current proportional to absolute temperature. For supply voltages between 4 V and 30 V, the device acts as a high impedance, constant current regulator passing 1  $\mu\text{A}/\text{K}$ . Laser trimming of the chip's thin-film resistors is used to calibrate the device to 298.2  $\mu\text{A}$  output at 298.2 K ( $25^{\circ}\text{C}$ ).

The AD590 should be used in any temperature-sensing application below  $150^{\circ}\text{C}$  in which conventional electrical temperature sensors are currently employed. The inherent low cost of a monolithic integrated circuit combined with the elimination of support circuitry makes the AD590 an attractive alternative for many temperature measurement situations. Linearization circuitry, precision voltage amplifiers, resistance measuring circuitry, and cold junction compensation are not needed in applying the AD590.

In addition to temperature measurement, applications include temperature compensation or correction of discrete components, biasing proportional to absolute temperature, flow rate measurement, level detection of fluids and anemometry. The AD590 is available in chip form, making it suitable for hybrid circuits and fast temperature measurements in protected environments.

The AD590 is particularly useful in remote sensing applications. The device is insensitive to voltage drops over long lines due to its high impedance current output. Any well-insulated twisted pair is sufficient for operation at hundreds of feet from the receiving circuitry. The output characteristics also make the AD590 easy to multiplex: the current can be switched by a CMOS multiplexer, or the supply voltage can be switched by a logic gate output.

### PIN CONFIGURATIONS

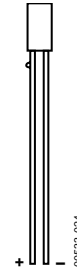

Figure 1. 2-Lead CQFP

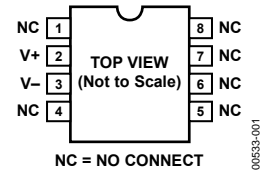

Figure 2. 8-Lead SOIC

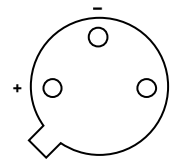

Figure 3. 3-Pin TO-52

### PRODUCT HIGHLIGHTS

1. The AD590 is a calibrated, 2-terminal temperature sensor requiring only a dc voltage supply (4 V to 30 V). Costly transmitters, filters, lead wire compensation, and linearization circuits are all unnecessary in applying the device.
2. State-of-the-art laser trimming at the wafer level in conjunction with extensive final testing ensures that AD590 units are easily interchangeable.
3. Superior interface rejection occurs because the output is a current rather than a voltage. In addition, power requirements are low (1.5 mW @ 5 V @  $25^{\circ}\text{C}$ ). These features make the AD590 easy to apply as a remote sensor.
4. The high output impedance ( $>10\text{ M}\Omega$ ) provides excellent rejection of supply voltage drift and ripple. For instance, changing the power supply from 5 V to 10 V results in only a 1  $\mu\text{A}$  maximum current change, or  $1^{\circ}\text{C}$  equivalent error.
5. The AD590 is electrically durable: it withstands a forward voltage of up to 44 V and a reverse voltage of 20 V. Therefore, supply irregularities or pin reversal does not damage the device.

# SPECIFICATIONS

## AD590J AND AD590K SPECIFICATIONS

25°C and  $V_S = 5\text{ V}$ , unless otherwise noted.<sup>1</sup>

Table 1.

Parameter	AD590J			AD590K			Unit
	Min	Typ	Max	Min	Typ	Max	
POWER SUPPLY							
Operating Voltage Range	<b>4</b>		30	<b>4</b>		30	V
OUTPUT							
Nominal Current Output @ 25°C (298.2K)		298.2			298.2		μA
Nominal Temperature Coefficient		1			1		μA/K
Calibration Error @ 25°C			<b>±5.0</b>			<b>±2.5</b>	°C
Absolute Error (Over Rated Performance Temperature Range)							
Without External Calibration Adjustment			<b>±10</b>			<b>±5.5</b>	°C
With 25°C Calibration Error Set to Zero			<b>±3.0</b>			<b>±2.0</b>	°C
Nonlinearity							
For TO-52 and CQFP Packages			<b>±1.5</b>			<b>±0.8</b>	°C
For 8-Lead SOIC Package			<b>±1.5</b>			<b>±1.0</b>	°C
Repeatability <sup>2</sup>			±0.1			±0.1	°C
Long-Term Drift <sup>3</sup>			±0.1			±0.1	°C
Current Noise		40			40		pA/√Hz
Power Supply Rejection							
4 V ≤ $V_S$ ≤ 5 V		0.5			0.5		μA/V
5 V ≤ $V_S$ ≤ 15 V		0.2			0.2		μV/V
15 V ≤ $V_S$ ≤ 30 V		0.1			0.1		μA/V
Case Isolation to Either Lead		10 <sup>10</sup>			10 <sup>10</sup>		Ω
Effective Shunt Capacitance		100			100		pF
Electrical Turn-On Time		20			20		μs
Reverse Bias Leakage Current (Reverse Voltage = 10 V) <sup>4</sup>		10			10		pA

<sup>1</sup> Specifications shown in **boldface** are tested on all production units at final electrical test. Results from those tests are used to calculate outgoing quality levels. All minimum and maximum specifications are guaranteed, although only those shown in **boldface** are tested on all production units.

<sup>2</sup> Maximum deviation between +25°C readings after temperature cycling between -55°C and +150°C; guaranteed, not tested.

<sup>3</sup> Conditions: constant 5 V, constant 125°C; guaranteed, not tested.

<sup>4</sup> Leakage current doubles every 10°C.

## ABSOLUTE MAXIMUM RATINGS

Table 3.

Parameter	Rating
Forward Voltage ( E+ or E-)	44 V
Reverse Voltage (E+ to E-)	-20 V
Breakdown Voltage (Case E+ or E-)	±200 V
Rated Performance Temperature Range <sup>1</sup>	-55°C to +150°C
Storage Temperature Range <sup>1</sup>	-65°C to +155°C
Lead Temperature (Soldering, 10 sec)	300°C

<sup>1</sup> The AD590 was used at -100°C and +200°C for short periods of measurement with no physical damage to the device. However, the absolute errors specified apply to only the rated performance temperature range.

Stresses above those listed under Absolute Maximum Ratings may cause permanent damage to the device. This is a stress rating only and functional operation of the device at these or any other conditions above those indicated in the operational section of this specification is not implied. Exposure to absolute maximum rating conditions for extended periods may affect device reliability.

# OUTLINE DIMENSIONS

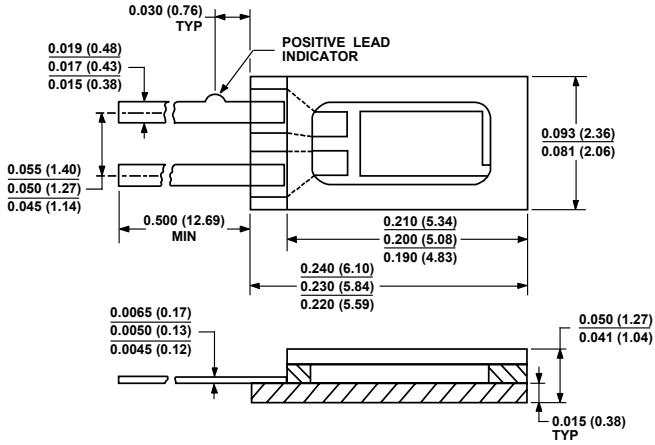
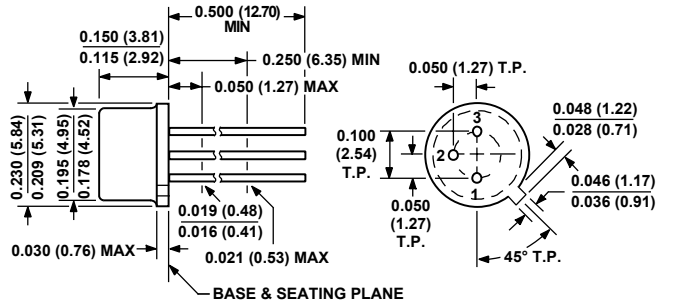
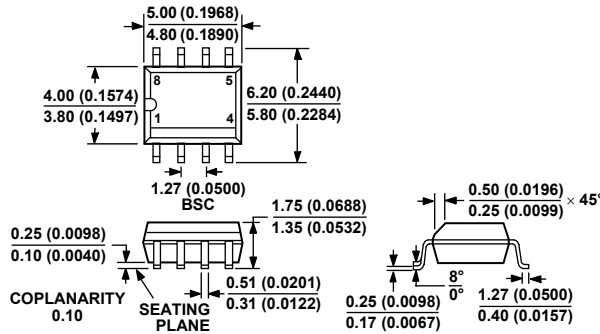

Figure 26. 2-Lead Ceramic Flat Package [CQFP]  
(F-2)  
Dimensions shown in inches and (millimeters)



CONTROLLING DIMENSIONS ARE IN INCHES; MILLIMETER DIMENSIONS (IN PARENTHESES) ARE ROUNDED-OFF INCH EQUIVALENTS FOR REFERENCE ONLY AND ARE NOT APPROPRIATE FOR USE IN DESIGN.

Figure 27. 3-Pin Metal Header Package [TO-52]  
(H-03)  
Dimensions shown in inches and (millimeters)



COMPLIANT TO JEDEC STANDARDS MS-012-AA  
CONTROLLING DIMENSIONS ARE IN MILLIMETERS; INCH DIMENSIONS (IN PARENTHESES) ARE ROUNDED-OFF MILLIMETER EQUIVALENTS FOR REFERENCE ONLY AND ARE NOT APPROPRIATE FOR USE IN DESIGN.

Figure 28. 8-Lead Standard Small Outline Package [SOIC]  
Narrow Body  
(R-8)  
Dimensions shown in millimeters and (inches)

# AD590

## ORDERING GUIDE

Model	Temperature Range	Package Description	Package Option
AD590JF <sup>1</sup>	-55°C to +150°C	2-Lead CQFP	F-2
AD590JH <sup>1</sup>	-55°C to +150°C	3-Pin TO-52	H-03
AD590JR	-55°C to +150°C	8-Lead SOIC	R-8
AD590JR-REEL	-55°C to +150°C	8-Lead SOIC	R-8
AD590JRZ <sup>2</sup>	-55°C to +150°C	8-Lead SOIC	R-8
AD590JRZ-RL <sup>2</sup>	-55°C to +150°C	8-Lead SOIC	R-8
AD590KF <sup>1</sup>	-55°C to +150°C	2-Lead CQFP	F-2
AD590KH <sup>1</sup>	-55°C to +150°C	3-Pin TO-52	H-03
AD590KR	-55°C to +150°C	8-Lead SOIC	R-8
AD590KR-REEL	-55°C to +150°C	8-Lead SOIC	R-8
AD590KRZ <sup>2</sup>	-55°C to +150°C	8-Lead SOIC	R-8
AD590KRZ-RL <sup>2</sup>	-55°C to +150°C	8-Lead SOIC	R-8
AD590LF <sup>1</sup>	-55°C to +150°C	2-Lead CQFP	F-2
AD590LH <sup>1</sup>	-55°C to +150°C	3-Pin TO-52	H-03
AD590MF <sup>1</sup>	-55°C to +150°C	2-Lead CQFP	F-2
AD590MH <sup>1</sup>	-55°C to +150°C	3-Pin TO-52	H-03
AD590JCHIPS	-55°C to +150°C	3-Pin TO-52	H-03

<sup>1</sup> Available in 883B; consult sales for data sheet.

<sup>2</sup> Z = Pb-free part.