

Product description

The T11 series of circuit breakers for equipment is a line of small, single pole push to reset, overload protective devices. The trip mechanism is of the superior «latch type». A high contact force can be maintained until the unit trips. This prevents electrical «noise» due to contact bounce and reduces the risk of contact welding which may occur with spring type mechanism.

The overload sensing is done with the aid of a thermal bimetal which has the advantage of being immune to high inrush currents and line transients. All T11-units are «positively trip-free». The contacts will open and will remain open during an overload. Contacts cannot be held in the closed position and they will not close automatically even if the closing command is maintained.

The T11 is specifically designed to protect equipment, wiring, transformers, power supplies, motors and sub-assemblies, such as printed circuit boards. For non-PCB mounting the T11 is connected to wiring with the popular quick connect terminals. Rated currents can be specified from 0,05 A to 16 A. All models are internationally approved.

The Swiss precision design is simple with few moving parts. This results in an extremely reliable CBE with high resistance against shock and vibration.

Available options

- Threaded neck type
- Snap-in type
- Drop-in type with soldering pins for PCB mounting
- Shunt terminal
- Additional position indication of the reset button by white ring

Special features

- Wide rated current range
- Variety of mounting styles
- Compact and reliable design
- Immunity to inrush currents and line transients
- Positively trip-free
- UL, CSA, VDE

Applications

- Electric power tools
- Electric household appliances
- Power supplies
- Battery chargers
- Sport machines
- Transformers

Effect of ambient temperature

The unit is calibrated for an ambient temperature of +23°C. To determine the rated current for a lower or higher ambient temperature, use a correction factor from the table below:

Ambient temperature [°C]	Correction factor
-5	0,87
0	0,90
+10	0,95
+23	1,00
+30	1,04
+40	1,10
+50	1,15
+60	1,20

Example

Rated current at +23°C 5,0 A
 Ambient temperature +40°C
 Correction factor 1,1
 Chosen rated current at
 +40°C ambient temperature
5,0 A x 1,1 = 5,5 A

Tripping characteristics

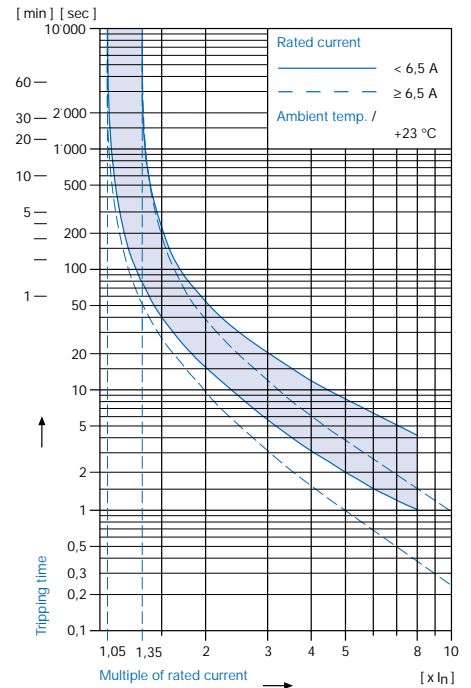



Technical data

Rated voltage U_e	See approvals, page 20	AC 120; 240 V DC 24; 32; 48 V
Rated current I_n	See approvals, page 20	AC/DC 0,05 – 16 A
Conditional short circuit current I_{nc}	EN 60934 PC1, AC 240 V	2000 A
Short circuit capacity I_{cn}	AC 240 V with $I_n < 6,5$ A AC 240 V with $I_n \geq 6,5$ A	$8 \times I_n$ 96 A
Class of protection	• Between live parts and accessible parts • Other parts	II I
Degree of protection	Accessible range Termination range	IP40 IP00
Dielectric strength	Accessible range	Test voltage AC 4000 V

Technical data (continued)		
Insulation resistance	DC 500 V	>100 MΩ
Permissible ambient temperature		-5°C to +60°C
Type of actuation	Reset type (manual)	R
Type of tripping	<ul style="list-style-type: none"> • Thermal • Positively trip-free 	TO
Weight		approx. 10 g

Approvals

			Rated current range	Rated voltage AC	Rated voltage DC
c  us	UL	UL 1077	0,05 – 16 A	240 V	48 V
	UL	CSA C22.2 235	0,05 – 16 A	240 V	48 V
	VDE	EN 60934	0,05 – 16 A	240 V	48 V

Models 214, 314, 614 and 814 are only available for rated currents ≤6 A I_n.
PCB mounting T11-818 by request.

Order code

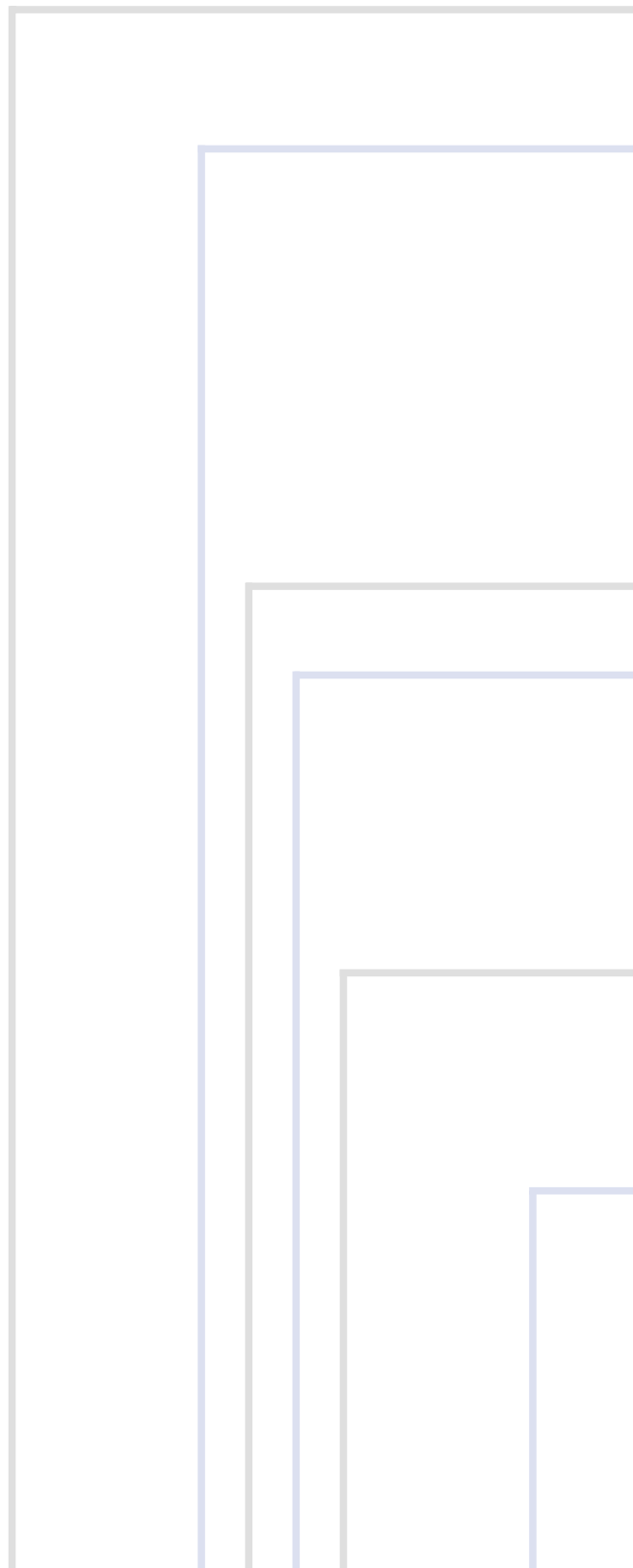

Basic type

T11 Single pole thermal overload protection switch, positively trip-free

Mounting style

- 2** Threaded neck type 3/8 – 27 UNS – 2 A
6 mm long with hexagonal nut
- 3** Threaded neck type 3/8 – 27 UNS – 2 A
8 mm long with hexagonal nut
- 6** Snap-in type
- 8** Drop-in type
 - with quick connect terminals
 - with soldering pins for PCB mounting

Actuation type

- 1** Reset type

Terminal type

- 1** 6,3 x 0,8 mm quick connect terminals IEC 61210
- 4** 2,8 x 0,8 mm quick connect terminals IEC 61210
- 8** Soldering pins Ø 1 mm tinned, horizontal PCB mounting
rated current max. 12 A

Construction variants

- N** Shunt terminal only for rated currents <6,5 A
- R** Setting indication on reset button

* (N; R; NR)

Rated current

0,05	0,1	0,15	0,2	0,3	0,4	0,5	0,6	0,7	0,8	0,9	1,0
1,1	1,2	1,3	1,4	1,5	1,6	1,7	1,8	1,9	2,0	2,1	2,3
2,5	2,8	3,0	3,3	3,5	4,0	4,5	5,0	5,5	6,0	6,5	7,0
7,5	8,0	8,5	9,0	9,5	10	11	12	13	14	15	16

Other rated currents by request

T 1 1 - 2 1 1 N R - 0,15 Order example

Threaded neck type

T11-211 ≤7,5 A

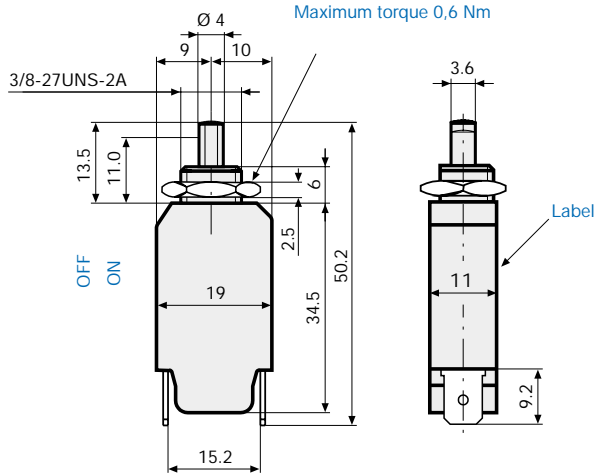

T11-211 >7,5 A

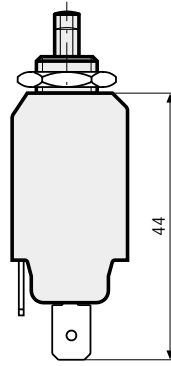

T11-211N

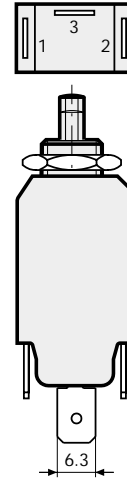

T11-214N

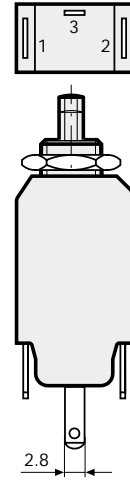

Cut-out

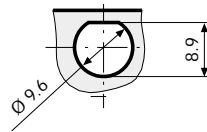

T11-311; T11-314

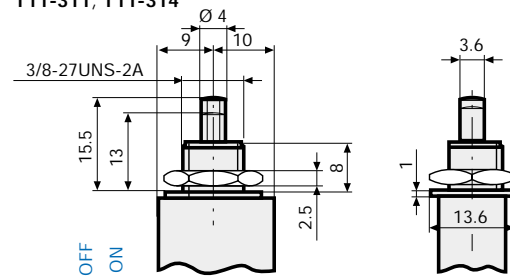

Snap-in type

T11-611 ≤7,5 A

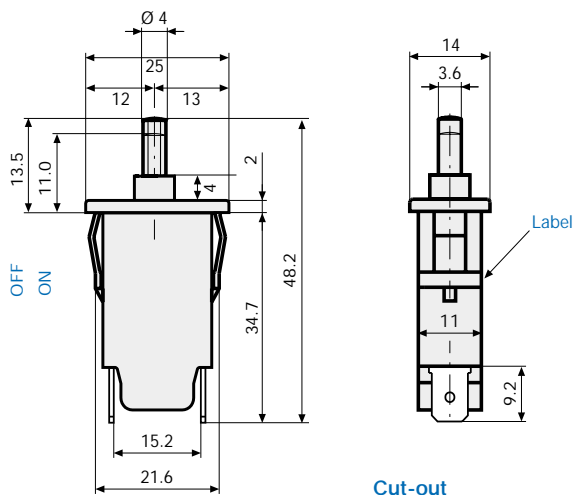

T11-611 >7,5 A

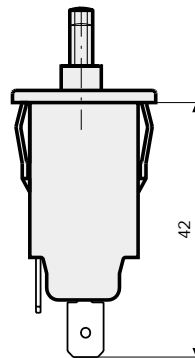

T11-611N

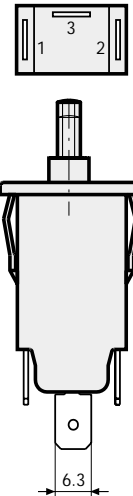

T11-614 N

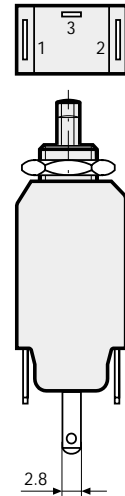

Cut-out

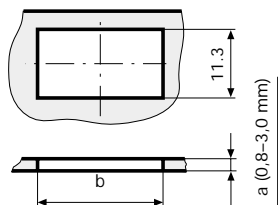

a	b
0,8	21,9
1,0	22,0
1,5	22,1
2,0	22,3
3,0	22,6

Drop-in type with quick connect terminal

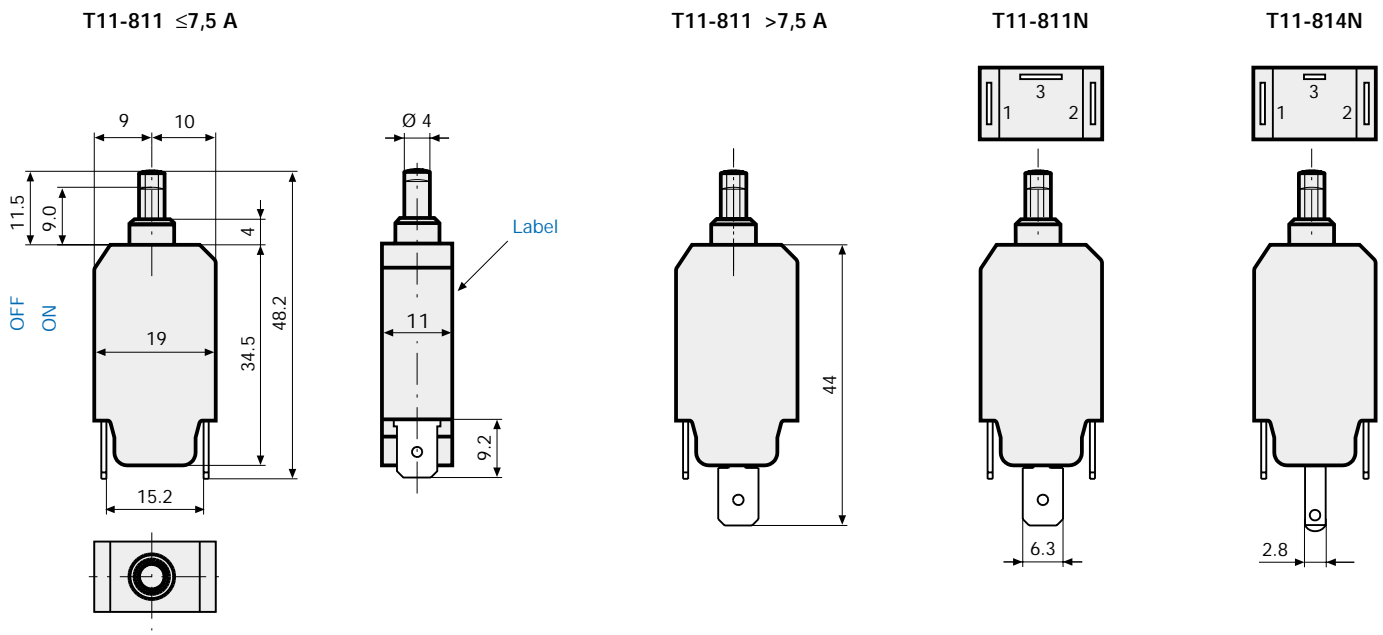

Drop-in type with soldering pins for PCB mounting

T11-818 $\leq 7,5$ A ($> 7,5 - 12$ A by request)

Drilling diagram

