

IEC Appliance Connector C14 with Line Switch 2-pole



C14

 70° C

**Description**

- Panel Mount:
Screw-on version from front or rear side, snap-in version from front side
- 2 Functions:
Appliance Inlet Protection class I, Line switch 2-pole
- Quick connect terminals 4.8 x 0.8 mm
- Alternative: version with line filter [KFB2](#)
- We recommend for new applications the new type [DC11](#)

Approvals

- VDE License Number: 40021945
- UL License Number: E96454
- CSA License Number: 38456

Characteristics

- All single elements are already wired
Unwired versions available on request
- Line switch non-illuminated or illuminated

Other versions on request

- Unwired versions
- Line switch with other rocker marking
- For protection class II

Weblinks

[Approvals](#), [RoHS](#), [CHINA-RoHS](#), [e-Store](#), [SCHURTER-Stock-Check](#), [Distributor-Stock-Check](#)

Technical Data

Ratings IEC	10A / 250VAC; 50Hz
Ratings UL/CSA	15A / 250VAC; 60Hz
Dielectric Strength	> 2.5kVAC between L-N > 3kVAC between L/N-PE (1 min/50Hz)
Allowable Operation Temp.	-25°C to 70°C
Degree of Protection	from front side IP 40 acc. to IEC 60529
Protection Class	Suitable for appliances with protection class I acc. to IEC 61140
Terminal	Quick connect terminals 4.8 x 0.8 mm
Panel Thickness s	Screw-on: max 6 mm Mounting screw torque max 0.5Nm Snap-in: 1.5/ 2/ 2.5 mm
Material: Housing	Thermoplastic, black, UL 94V-0

Appliance-Inlet/-Outlet	C14 acc. to IEC/EN 60320-1, UL 498, CSA C22.2 no. 42 (for cold conditions) pin-temperature 70 °C, 10A, Protection class I
Line Switch	Rocker switch 2-pole, non-illuminated or illuminated, acc. to IEC 61058-1 Technical details

Dimensions

Screw-on mounting

Length |-----| 59 mm
Snap-in mounting

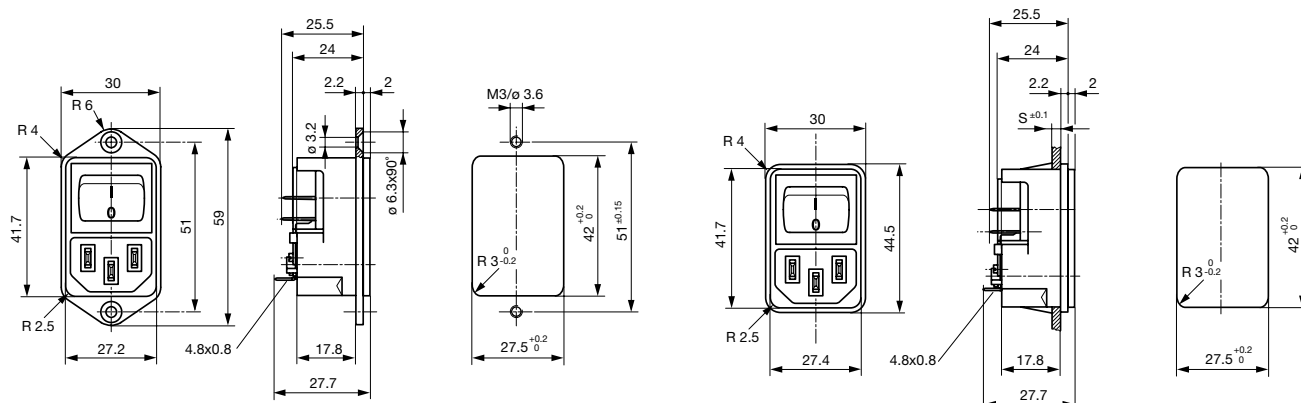

Diagrams

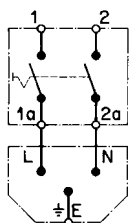

non-illuminated

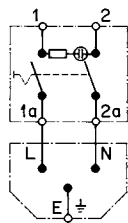

illuminated

Variants

with internal connections

Panel mounting	Panel Thickness s [mm]	Illumination	Rated voltage 125/250 [V]	Color	Order Number
Screw-on	-	●	250	red	4302.2101
Screw-on	-	●	250	green	4302.2141
Screw-on	-	-	-	-	4302.2001
		●	250	red	4302.2102
		●	250	green	4302.2142
		●	250	red	4302.2103
		●	250	green	4302.2143
		●	250	red	4302.2104
		●	250	green	4302.2144
Snap-in	1.5	-	-	-	4302.2002
Snap-in	2	-	-	-	4302.2003
Snap-in	2.5	-	-	-	4302.2004

Packaging unit

50 Pcs