

**BTA<sup>®</sup>**  
Rotary Actuators

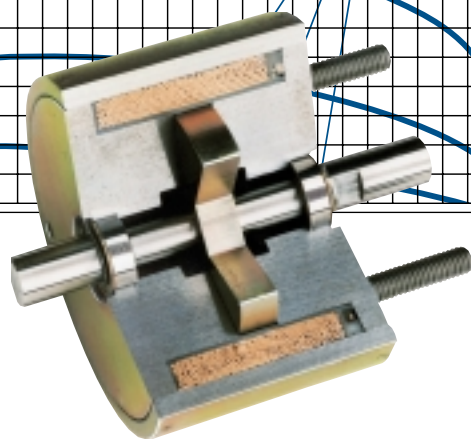

# BTA® Brushless Torque Actuators

ROTARY BTA

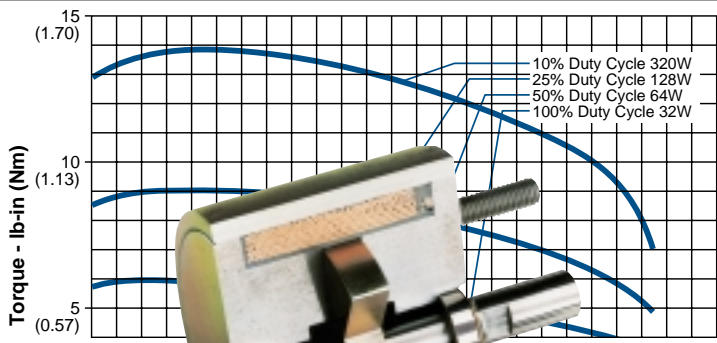

- Controllable velocity and position
- Quiet, shock-free operation
- 100+ million cycle life
- No axial stroke
- Adaptable to closed loop operation
- Completely enclosed construction
- Excellent unit-to-unit performance consistency
- Low power consumption

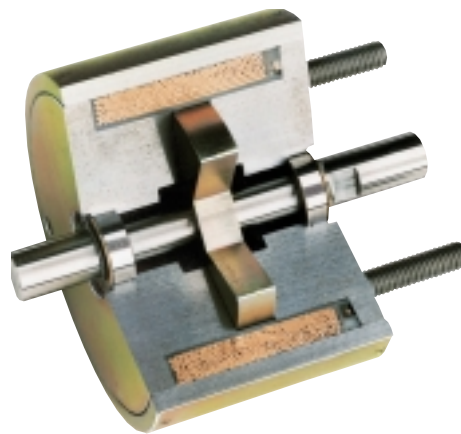

## BTA Principle of Operation

The BTA has a single phase coil with three stator poles and matching rotor poles. When the coil is energized, the poles align along the flux path. With the three pole design, it is possible to have a stroke of up to 45°. In practical usage, external stops should be used to attain maximum unit life. Subsequently, the stroke angle is slightly shorter. Use of such mechanical stops also serve to limit the actuator stroke to its optimum stroke/torque capacity. By not requiring full stroke actuation, the BTA offers maximum design flexibility across a wide range of stroke angles and torque requirements.

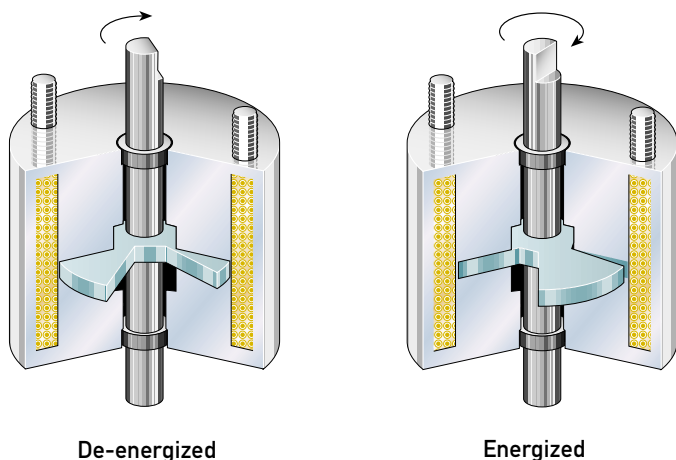

BTA rotary, non-axial stroke actuators are a good solution for applications requiring reliable, low hysteresis operation with a good torque profile as required for proportional operation.

Using simple pulse width modulation (PWM) to control coil current, the BTA allows open or closed loop velocity and position control. Such proportional control is ideal for silent, shock-free actuation applications. (In open loop applications, PWM improves hysteresis over variable DC voltage control.)

The addition of position feedback, and the subsequent improved system stiffness and accuracy, enables the BTA to be used in closed loop applications.

The bearing system consists of two ball-type bearings which are key to low hysteresis operation.

## Quiet

The BTA can operate virtually noise free. Electronically controlled, the BTA provides soft, shock-free cycling without the noise associated with end-of-stroke mechanical stops.

For machines such as the mail sorter pictured at right, which utilizes hundreds of these actuators, the BTA is used in conjunction with cushioned external stops to minimize noise and extend the unit's life to that of the precision ball bearings.

# BTA<sup>®</sup> Brushless Torque Actuators

## Rapid Cycling

The BTA actuator requires only milliseconds to rotate through its entire stroke. It can maintain this extremely fast operating speed repetitively without diminishing accuracy or repeatability, or reducing the overall life of the unit.

## Rugged

The BTA design eliminates the axial travel associated with conventional rotary actuators. In so doing, the BTA eliminates loading on associated mechanical linkages, and reduces the number of moving parts and the wear they receive. The BTA is self-contained in an industry standard size which enables easy mounting and interchangeability. The unit is permanently lubricated and requires no adjustment or maintenance over its entire life.

## Powerful . . . with Less Power

The BTA actuator offers considerably more torque than comparable sized rotary actuator designs.

Even with its high torque output, the BTA requires 40% less power input than competitive units. On high volume applications such as this mail sorter, the BTA conserves as much as 18.9 watts per actuator cycle.

## Design Considerations

### Performance Curves

The torque curves on the following pages are typical data taken with a 20°C coil and have not been derated. Typical derating factors are 30% due to coil heating.

### Duty Cycle

Duty cycle is determined by: ON time/(ON + OFF time).

For example: an actuator operated for 30 seconds, then off for 90 seconds.  
 $30 \text{ sec ON} / (30 \text{ Sec ON} + 90 \text{ sec OFF}) = 30/120 = 1/4 \text{ or } 25\% \text{ duty cycle}$

BTA actuators are rated for various duty cycles ranging from continuous to 10% duty.

### Life

When selecting a BTA actuator, as with any other style, it is important to consider the effects of heat on life. When used with a constant voltage supply, an increase in coil temperature reduces the work output and the life of the unit. Standard life is more than 100,000,000 cycles.

## Power Requirements

Voltage applied to the actuator must be matched to the coil wire size for proper operation. Actuators are cataloged in coil awgs ranging from #23 up to #35 to accommodate your input power. Refer to the individual model specification pages for coil wire awg recommendations. Many other coil awg sizes are available. Please feel free to contact our application engineering department for availability.

## Options and Modified Designs

Even though our standard BTAs are in stock, our customers often require a product with unique features or performance capabilities. In fact, almost 80% of all products that we make are either modified or custom built to meet our customers' exact application requirements.

So, if you don't find what you're looking for in the catalog, give us a call to discuss your needs with one of our application engineers.

## Typical Examples of Custom Features

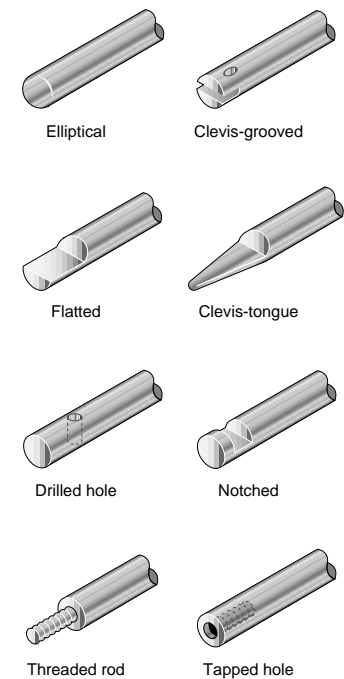

ROTARY BTA

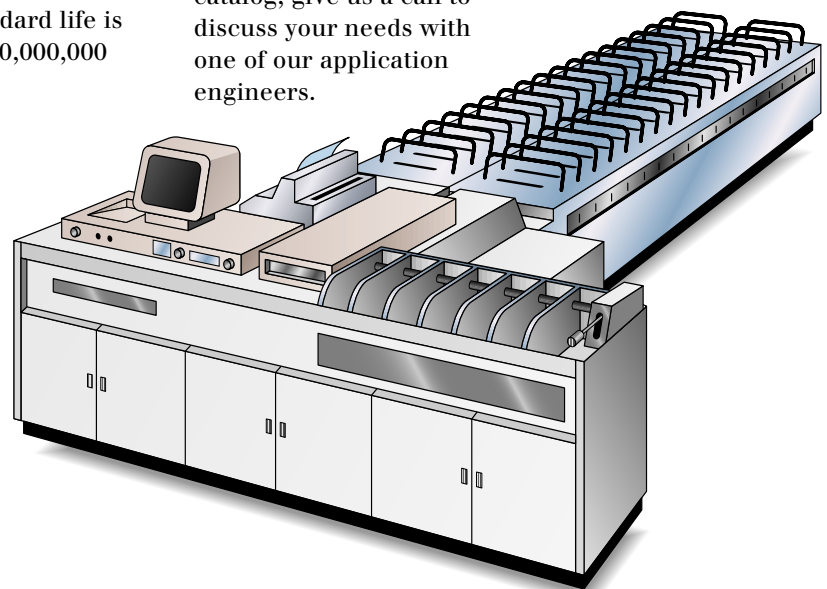

# BTA® Selection

Brushless Torque Actuators are available in five sizes. Use the selection overview chart to determine which size offers the desired performance and mechanical specifications. Refer to the individual size specification pages for complete performance and mechanical data.

## BTA Selection Overview

Size	Package Dimensions (in)		Maximum Stroke (degrees)	Gross Starting Torque (lb-in)				Gross Ending Torque (lb-in)			
	Dia.	Length		@ Specified Duty Cycle				@ Specified Duty Cycle			
				100%	50%	25%	10%	100%	50%	25%	10%
2EV	1.188	0.719	45	N/A*	0.28	0.50	1.00	N/A*	0.19	0.33	0.58
3EV	1.375	0.890	45	0.28	0.45	0.84	1.66	0.22	0.31	0.53	0.88
4EV	1.625	1.055	45	0.40	0.92	1.60	2.85	0.36	0.64	1.00	1.60
5EV	1.937	1.265	45	1.36	2.36	3.72	6.00	1.04	1.64	2.60	4.20
6EV	2.312	1.625	45	3.40	5.80	8.60	12.90	2.00	3.70	5.00	7.00

All data is at 20°C coil temperature. Torque outputs degrade with elevated temperatures.

\* Not recommended for 100% duty.

## How to Use BTA Performance Charts

- Select one of the four columns which provides the appropriate duty cycle. (For example 50%.)
- Reading down this column provides a variety of performance and electrical data including maximum on time, watts, and amp turns.
- Following down the column further into the VDC ratings, select the voltage which most closely matches your supply voltage. (For example, 7.6 for an 8 VDC power supply.)
- Read across (to the left) to select the awg suffix to complete the part number when ordering. (In this example using our 2EV chart, 28 awg is required, thus to order, specify: 195190-028.)

## Performance

Maximum Duty Cycle	100%	50%	25%	10%
Maximum ON Time (sec) when pulsed continuously	∞	100	36	7
Maximum ON Time (sec) for single pulse	∞	162	44	8
Typical Energize Time (msec)	20	15	11	8
Watts (@ 20°C)	10	20	40	100
Ampere Turns (@ 20°C)	331	469	663	1048

## Coil Data

awg (0XX)*	Resistance (@20°C)	# Turns <sup>5</sup>	VDC (Nom)	VDC (Nom)	VDC (Nom)	VDC (Nom)
24	0.47	72	2.2	3.1	4.3	6.9
25	0.67	82	2.6	3.7	5.2	8.2
26	0.94	92	3.1	4.3	6.1	9.7
27	1.33	104	3.6	5.2	7.3	11.5
28	2.86	174	5.4	7.6	10.7	16.9
29	4.01	195	6.3	9.0	12.7	20.0
30	7.69	292	8.8	12.4	17.5	27.7
31	10.80	328	10.4	14.7	20.8	32.9
32	19.26	460	13.9	19.6	27.8	43.9
33	26.96	515	16.4	23.2	32.8	52.0
34	45.82	690	21.4	30.3	42.8	68.0
35	63.76	768	25.3	35.7	50.0	80.0

All specifications subject to change without notice.

Part Numbers: Clockwise Rotation 195190-0XX  
Counter-Clockwise Rotation 195622-0XX

## Performance

Maximum Duty Cycle*	50%	25%	10%
Maximum ON Time (sec) when pulsed continuously <sup>1</sup>	15	6	2
Maximum ON Time (sec) for single pulse <sup>2</sup>	44	15	4
Typical Energize Time (msec) <sup>3</sup>	15	11	8
Watts (@ 20°C)	20	40	100
Ampere Turns (@ 20°C)	469	663	1048

### Coil Data

awg (0XX) <sup>4</sup>	Resistance (@20°C)	# Turns <sup>5</sup>	VDC (Nom)	VDC (Nom)	VDC (Nom)
24	0.47	72	3.1	4.3	6.9
25	0.67	82	3.7	5.2	8.2
26	0.94	92	4.3	6.1	9.7
27	1.33	104	5.2	7.3	11.5
28	2.86	174	7.6	10.7	16.9
29	4.01	195	9.0	12.7	20.0
30	7.69	292	12.4	17.5	27.7
31	10.80	328	14.7	20.8	32.9
32	19.26	460	19.6	27.8	43.9
33	26.96	515	23.2	32.8	52.0
34	45.82	690	30.3	42.8	68.0
35	63.76	768	35.7	50.0	80.0

\*Not recommended for 100% duty cycle.

## Specifications

Dielectric Strength	1000 VRMS
Recommended Minimum Heat Sink	Maximum watts dissipated by solenoid are based on an unrestricted flow of air at 20°C, with solenoid mounted on the equivalent of an aluminum plate measuring 3-3/8" square by 1/8" thick
Thermal Resistance	10.8 (°C/watt)
Rotor Inertia	2.56 (gm-cm <sup>2</sup> )
Weight	3.0 oz (85 gms)
Dimensions	Ø1.188" x 0.719" (See page B10)

## How to Order

Add the coil awg number (0XX) to the part number (for example: to order a 25% duty cycle clockwise rotation unit rated at 12.7 VDC, specify 195190-029).

Please see [www.ledex.com](http://www.ledex.com) (click on Stock Products tab) for our list of stock products available through our North American distributors.

- Continuously pulsed at stated watts and duty cycle
- Single pulse at stated watts (with coil at ambient room temperature 20°C)
- Typical energize time based on a 0.5 oz-in torque load including 14 gm-cm<sup>2</sup> of inertia
- Other coil awg sizes available — please consult factory
- Reference number of turns

## Size 2EV — Typical Torque @ 20°C

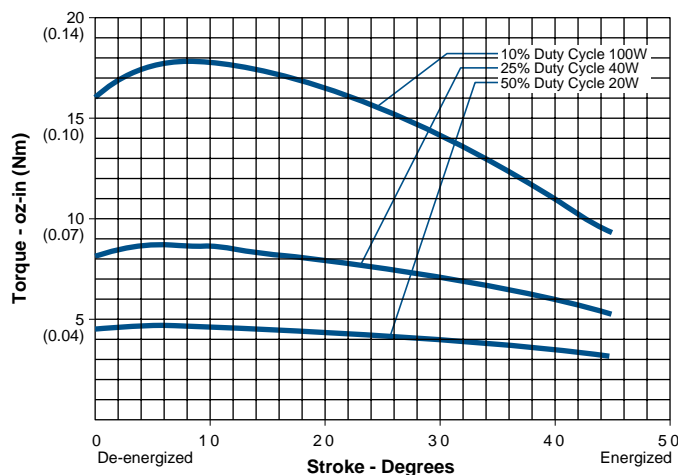

### Notes:

Torque curves shown are without spring.

Typical standard spring has a torque of 1.0 oz-in.

Torque values are for reference only.

All specifications subject to change without notice.

# BTA® Size 3EV

Part Numbers: Clockwise Rotation 195191-0XX

Counter-Clockwise Rotation 195623-0XX

ROTARY BTA

## Performance

Maximum Duty Cycle	100%	50%	25%	10%
Maximum ON Time (sec) when pulsed continuously <sup>1</sup>	∞	10	3	1
Maximum ON Time (sec) for single pulse <sup>2</sup>	∞	26	10	4
Typical Energize Time (msec) <sup>3</sup>	25	17	12	9
Watts (@ 20°C)	13	26	52	130
Ampere Turns (@ 20°C)	362	512	729	1,144

### Coil Data

awg (0XX) <sup>4</sup>	Resistance (@20°C)	# Turns <sup>5</sup>	VDC (Nom)	VDC (Nom)	VDC (Nom)	VDC (Nom)
23	0.26	44	1.9	2.6	3.7	5.9
24	0.38	50	2.2	3.1	4.4	7.0
25	0.53	56	2.6	3.7	5.2	8.3
26	1.54	126	4.5	6.3	9.0	14.2
27	2.15	140	5.3	7.5	10.6	16.7
28	3.04	158	6.3	8.9	12.6	19.9
29	4.24	176	7.4	10.5	14.9	23.5
30	9.16	297	10.9	15.4	21.8	34.5
31	12.90	333	12.9	18.3	25.9	40.9
32	18.04	372	15.3	21.6	30.6	48.4
33	34.10	552	21.0	29.8	42.1	66.5
34	47.70	616	25.0	35.2	49.8	78.7

## Specifications

Dielectric Strength	1,000 VRMS (23-28 awg); 1,200 VRMS (29-34 awg)
Recommended Minimum Heat Sink	Maximum watts dissipated by solenoid are based on an unrestricted flow of air at 20°C, with solenoid mounted on the equivalent of an aluminum plate measuring 4-5/8" square by 1/8" thick
Thermal Resistance	8.53 (°C/watt)
Rotor Inertia	9.14 (gm-cm <sup>2</sup> )
Weight	5.0 oz (142 gms)
Dimensions	Ø1.375" x 0.890" (See page B10)

## How to Order

Add the coil awg number (0XX) to the part number (for example: to order a 25% duty cycle clockwise rotation unit rated at 25.9 VDC, specify 195191-051).

Please see [www.ledex.com](http://www.ledex.com) (click on Stock Products tab) for our list of stock products available through our North American distributors.

- Continuously pulsed at stated watts and duty cycle
- Single pulse at stated watts (with coil at ambient room temperature 20°C)
- Typical energize time based on a 0.8 oz-in torque load including 14 gm-cm<sup>2</sup> of inertia
- Other coil awg sizes available — please consult factory
- Reference number of turns

## Size 3EV — Typical Torque @ 20°C

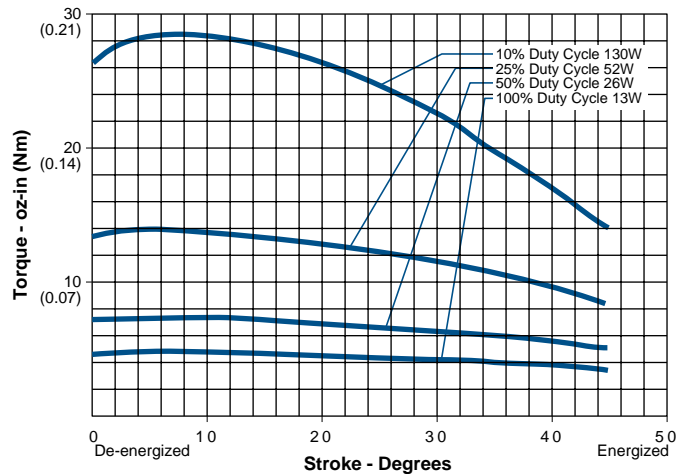

### Notes:

Torque curves shown are without spring.

Typical standard spring has a torque of 1.9 oz-in.

Torque values are for reference only.

All specifications subject to change without notice.



# BTA® Size 4EV

Part Numbers: Clockwise Rotation 190834-0XX  
Counter-Clockwise Rotation 195624-0XX

## Performance

Maximum Duty Cycle	100%	50%	25%	10%
Maximum ON Time (sec) when pulsed continuously <sup>1</sup>	∞	40	15	4
Maximum ON Time (sec) for single pulse <sup>2</sup>	∞	108	34	9
Typical Energize Time (msec) <sup>3</sup>	27	19	14	10
Watts (@ 20°C)	14.5	29	58	145
Ampere Turns (@ 20°C)	510	721	1020	1613

### Coil Data

awg (0XX) <sup>4</sup>	Resistance (@20°C)	# Turns <sup>5</sup>	VDC (Nom)	VDC (Nom)	VDC (Nom)	VDC (Nom)
23	0.71	104	3.2	4.5	6.4	10.1
24	1.54	174	4.7	6.7	9.4	14.9
25	2.15	195	5.6	7.9	11.2	17.6
26	3.01	219	6.6	9.3	13.2	20.9
27	5.78	328	9.2	12.9	18.3	28.9
28	8.09	368	10.8	15.3	21.7	34.3
29	14.40	515	14.5	20.4	28.9	45.7
30	20.11	575	18.9	26.7	37.7	59.6
31	34.40	774	22.3	31.6	44.6	71.0
32	56.60	1008	28.7	40.5	57.0	91.0
33	91.40	1288	36.0	52.0	73.0	115.0

## Specifications

Dielectric Strength	1000 VRMS (23-24 awg); 1200 VRMS (25-33 awg)
Recommended Minimum Heat Sink	Maximum watts dissipated by solenoid are based on an unrestricted flow of air at 20°C, with solenoid mounted on the equivalent of an aluminum plate measuring 6-1/4" square by 1/8" thick
Thermal Resistance	7.63 (°C/watt)
Rotor Inertia	13.92 (gm-cm <sup>2</sup> )
Weight	8.0 oz (227 gms)
Dimensions	Ø1.625" x 1.055" (See page B10)

## How to Order

Add the coil awg number (0XX) to the part number (for example: to order a 25% duty cycle clockwise rotation unit rated at 15.2 VDC, specify 190834-026).

Please see [www.ledex.com](http://www.ledex.com) (click on Stock Products tab) for our list of stock products available through our North American distributors.

- Continuously pulsed at stated watts and duty cycle
- Single pulse at stated watts (with coil at ambient room temperature 20°C)
- Typical energize time based on a 2.4 oz-in torque load including 14 gm-cm<sup>2</sup> of inertia
- Other coil awg sizes available — please consult factory
- Reference number of turns

## Size 4EV — Typical Torque @ 20°C

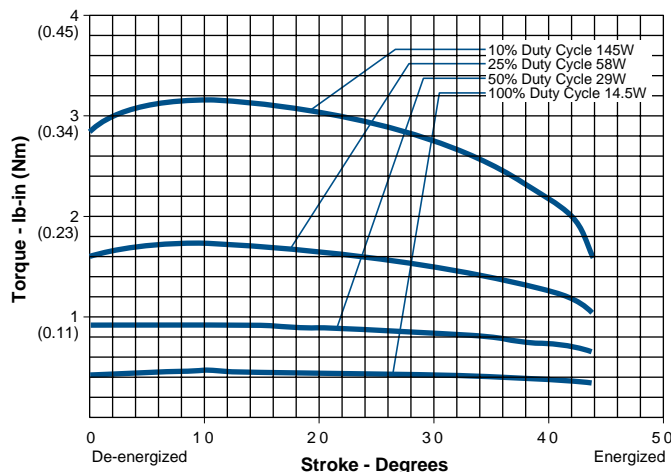

### Notes:

Torque curves shown are without spring.

Typical standard spring has a torque of 3.0 oz-in.

Torque values are for reference only.

All specifications subject to change without notice.

# BTA® Size 5EV

Part Numbers: Clockwise Rotation 190835-0XX  
Counter-Clockwise Rotation 195625-0XX

ROTARY BTA

## Performance

Maximum Duty Cycle	100%	50%	25%	10%		
Maximum ON Time (sec) when pulsed continuously <sup>1</sup>	∞	40	15	4		
Maximum ON Time (sec) for single pulse <sup>2</sup>	∞	109	36	10		
Typical Energize Time (msec) <sup>3</sup>	27	18	14	10		
Watts (@ 20°C)	21	42	84	210		
Ampere Turns (@ 20°C)	621	878	1242	1964		
Coil Data						
awg (0XX) <sup>4</sup>	Resistance (@20°C)	# Turns <sup>5</sup>	VDC (Nom)	VDC (Nom)	VDC (Nom)	VDC (Nom)
23	1.05	128	4.7	6.6	9.4	14.8
24	2.24	213	6.9	9.7	13.7	21.7
25	3.16	240	8.1	11.5	16.3	25.8
26	4.45	270	9.7	13.7	19.3	30.6
27	8.50	404	13.4	18.9	26.7	42.2
28	11.90	452	15.8	22.3	31.6	50.0
29	21.10	630	21.0	29.7	42.1	67.0
30	29.50	705	24.9	35.2	49.8	78.7
31	50.30	948	32.5	46.0	65.0	103.0
32	82.70	1232	41.7	59.0	83.0	132.0
33	134.00	1576	53.0	75.0	106.0	168.0

## Specifications

Dielectric Strength	1000 VRMS (23 awg); 1200 VRMS (24-33 awg)
Recommended Minimum Heat Sink	Maximum watts dissipated by solenoid are based on an unrestricted flow of air at 20°C, with solenoid mounted on the equivalent of an aluminum plate measuring 7-1/2" square by 1/8" thick
Thermal Resistance	5.36 (°C/watt)
Rotor Inertia	30.36 (gm-cm <sup>2</sup> )
Weight	13.5 oz (382 gms)
Dimensions	Ø1.937" x 1.265" (See page B10)

## How to Order

Add the coil awg number (0XX) to the part number (for example: to order a 25% duty cycle clockwise rotation unit rated at 26.7 VDC, specify 190835-027).

Please see [www.ledex.com](http://www.ledex.com) (click on Stock Products tab) for our list of stock products available through our North American distributors.

- Continuously pulsed at stated watts and duty cycle
- Single pulse at stated watts (with coil at ambient room temperature 20°C)
- Typical energize time based on a 5.0 oz-in torque load including 14 gm-cm<sup>2</sup> of inertia
- Other coil awg sizes available — please consult factory
- Reference number of turns

## Size 5EV — Typical Torque @ 20°C

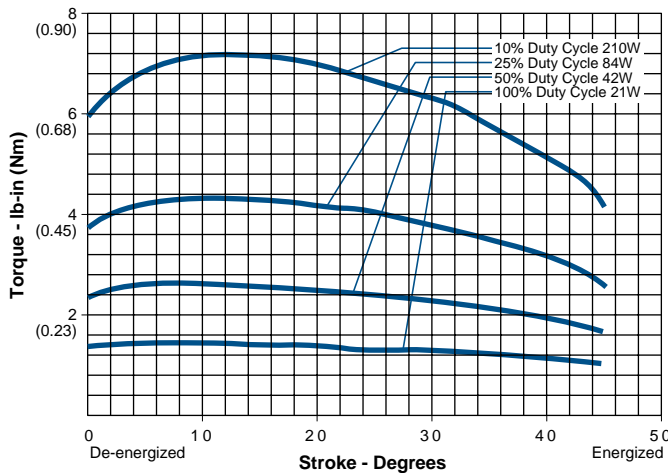

### Notes:

Torque curves shown are without spring.

Typical standard spring has a torque of 4.0 oz-in.

Torque values are for reference only.

All specifications subject to change without notice.



# BTA® Size 6EV

Part Numbers: Clockwise Rotation 190836-0XX  
Counter-Clockwise Rotation 195626-0XX

## Performance

Maximum Duty Cycle	100%	50%	25%	10%
Maximum ON Time (sec) when pulsed continuously <sup>1</sup>	∞	40	15	5
Maximum ON Time (sec) for single pulse <sup>2</sup>	∞	143	47	11
Typical Energize Time (msec) <sup>3</sup>	48	21	15	11
Watts (@ 20°C)	32	64	128	320
Ampere Turns (@ 20°C)	980	1386	1960	3100

### Coil Data

awg (0XX) <sup>4</sup>	Resistance (@20°C)	# Turns <sup>5</sup>	VDC (Nom)	VDC (Nom)	VDC (Nom)	VDC (Nom)
23	2.65	267	9.2	13.0	18.4	29.1
24	5.02	396	12.7	17.9	25.4	40.1
25	7.03	444	15.0	21.2	30.0	47.4
26	12.60	625	20.1	28.4	40.2	63.5
27	17.60	700	23.8	33.6	47.5	75.1
28	29.90	936	30.9	43.7	61.9	97.8
29	49.50	1225	39.8	56.0	80.0	126.0
30	79.70	1560	51.0	71.0	101.0	160.0
31	126.50	1962	64.0	90.0	127.0	201.0
32	198.30	2440	80.0	113.0	159.0	252.0
33	306.20	2992	99.0	140.0	198.0	313.0

## Specifications

Dielectric Strength	1,000 VRMS (23 awg); 1200 VRMS (24-33 awg)
Recommended Minimum Heat Sink	Maximum watts dissipated by solenoid are based on an unrestricted flow of air at 20°C, with solenoid mounted on the equivalent of an aluminum plate measuring 12-3/8" square by 1/8" thick
Thermal Resistance	3.58 (°C/watt)
Rotor Inertia	67.15 (gm-cm <sup>2</sup> )
Weight	25.0 oz (709 gms)
Dimensions	Ø2.312" x 1.625" (See page B10)

## How to Order

Add the coil awg number (0XX) to the part number (for example: to order a 25% duty cycle clockwise rotation unit rated at 25.4 VDC, specify 190836-024).

Please see [www.ledex.com](http://www.ledex.com) (click on Stock Products tab) for our list of stock products available through our North American distributors.

- Continuously pulsed at stated watts and duty cycle
- Single pulse at stated watts (with coil at ambient room temperature 20°C)
- Typical energize time based on a 14.0 oz-in torque load including 14 gm-cm<sup>2</sup> of inertia
- Other coil awg sizes available — please consult factory
- Reference number of turns

## Size 6EV — Typical Torque @ 20°C

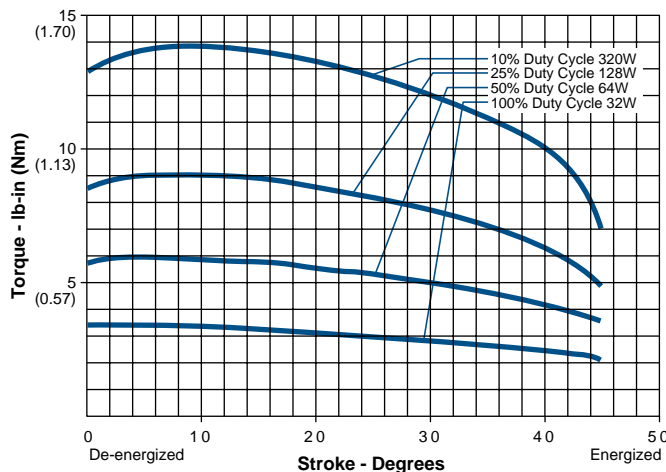

### Notes:

Torque curves shown are without spring.

Typical standard spring has a torque of 8.0 oz-in.

Torque values are for reference only.

All specifications subject to change without notice.

# BTA® Dimensions

inches (mm)

## Size 2EV

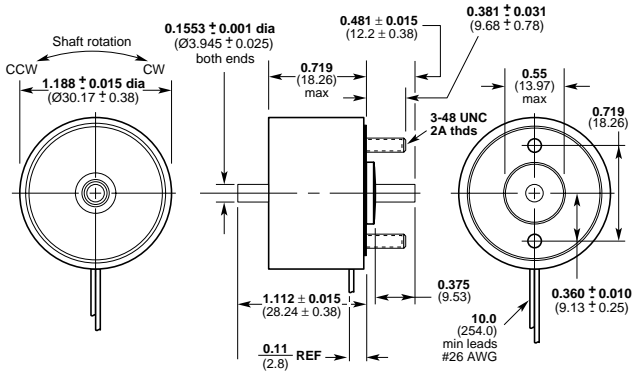

## Size 3EV

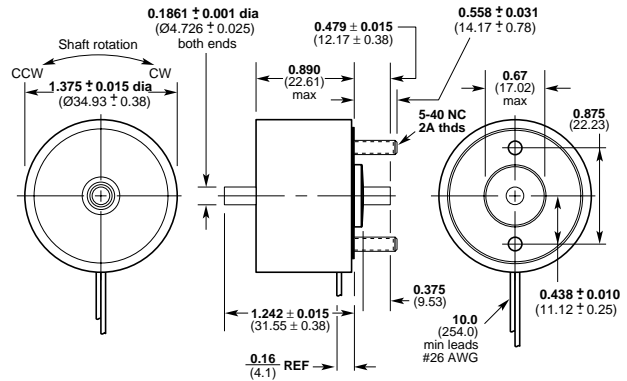

## Size 4EV

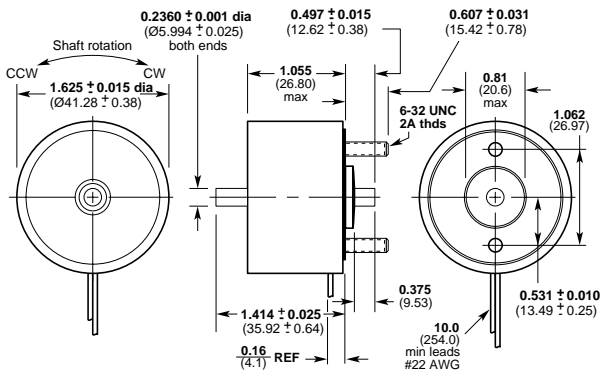

## Size 5EV

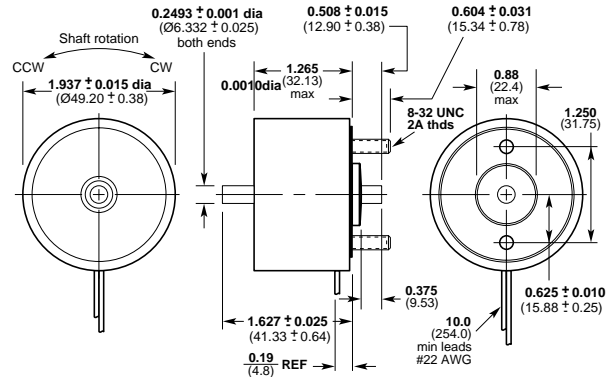

## Size 6EV

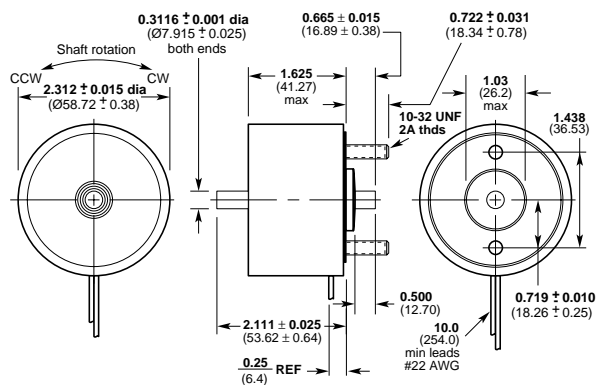

All specifications subject to change without notice.