

See "Part Drawing" for Details

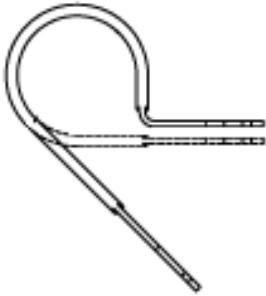

Part Number	Description
-------------	-------------

NE5	Clamp, Screw Mnt, Blk/Alum, 5/16" Hold
---------------------	--



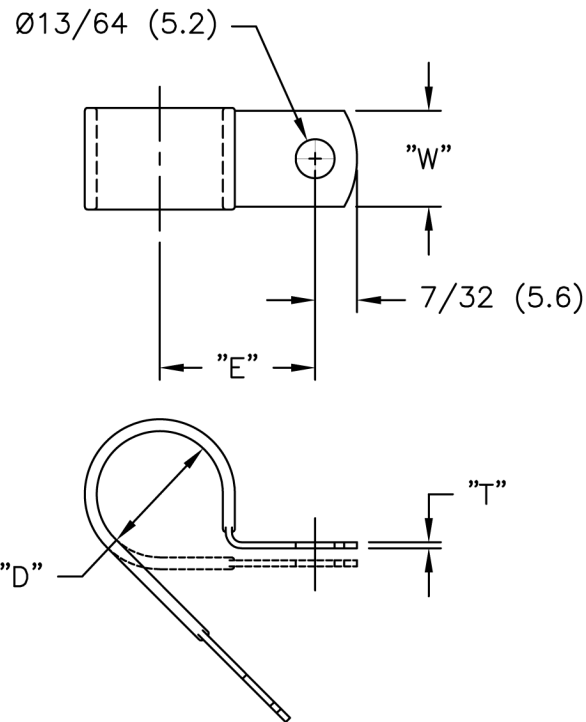

PART NO.	HOLDING DIA. "D"	"E" REF.	"T"	"W"		
NE3	3/16 (4.8)	.50 (12.7)	1/32 (0.8)	3/8 (9.5)		
NE4	1/4 (6.4)	.53 (13.5)				
NE5	5/16 (7.9)	.56 (14.2)				
NE6	3/8 (9.5)	.59 (15.0)				
NE7	7/16 (11.1)	.62 (15.7)				
NE8	1/2 (12.7)	.65 (16.5)				
NE9	9/16 (14.3)	.75 (19.1)				
NE10	5/8 (15.9)	.78 (19.8)				
NE11	11/16 (17.5)	.81 (20.6)			1/16 (1.6)	1/2 (12.7)
NE12	3/4 (19.1)	.84 (21.3)				
NE14	7/8 (22.2)	.90 (22.9)				
NE16	1 (25.4)	.96 (24.4)				
NE18	1-1/8 (28.6)	1.05 (26.7)				
NE20	1-1/4 (31.8)	1.11 (28.2)				

NOTES:

- MAT'L: ALUMINUM ALLOY 5052 H-32 (RMS-199).
- PLASTISOL DIPPED (RMS-200), NOMINAL THICKNESS 1/32 (0.8).
- COLOR: BLACK.

TITLE: CABLE CLAMPS, PLASTISOL DIPPED		DWG IN IN (MM)		FINAL			
TOLERANCES UNLESS NOTED .XX=±.010 .XXX=±.005 FRAC=±1/64 ANG=±1'	FILE # NE	DWN: P.B.	APP:	PART #		PRINT TYPE	
	MAT'L: SEE NOTES	DT: 01-18-95	DT:	NE SERIES		CA	
	RE: RICHCO, INC.	RICHCO INC.					

REV	DESCRIPTION	ENGR	DATE
D	SEE CO 200143 FOR CHANGES	SK	03.25.08
C	SEE ECN #927 FOR CHANGES	SK	01.31.05
B	DRAWING UPDATED AND CHANGED FILE NO.	SM	09.26.01
A	CONVERTED TO ACAD	PB	01.18.95