

NYLON 6/6 UL 94 V-2 (RMS-01). COLOR: NATURAL PART NO.	NYLON 6/6 UL 94 V-0 (RMS-75). COLOR: NATURAL PART NO.	NYLON 6/6 UL 94 V-2 (RMS-01). COLOR: BLACK PART NO.	"D" HOLDING DIA.	"E" REF.
N-2B	----	N-2B-BK	1/8 [3.2]	21/64 [8.3]
N-3B	N-3B-75	N-3B-BK	3/16 [4.8]	25/64 [9.9]
N-4B	N-4B-75	N-4B-BK	1/4 [6.4]	27/64 [10.7]
N-5B	N-5B-75	N-5B-BK	5/16 [7.9]	29/64 [11.5]
N-6B	N-6B-75	N-6B-BK	3/8 [9.5]	31/64 [12.3]
N-7B	----	N-7B-BK	7/16 [11.1]	17/36 [13.5]
N-8B	N-8B-75	N-8B-BK	1/2 [12.7]	9/16 [14.3]
N-9B	----	N-9B-BK	9/16 [14.3]	19/32 [15]
N-10B	N-10B-75	N-10B-BK	5/8 [15.9]	5/8 [15.9]
N-11B	----	N-11B-BK	11/16 [17.5]	21/32 [16.6]
N-12B	*N-12B-75	N-12B-BK	3/4 [19.1]	49/64 [19.5]
N-14B	*N-14B-75	N-14B-BK	7/8 [22.2]	13/16 [20.6]
N-16B	*N-16B-75	N-16B-BK	1 [25.4]	29/32 [23]
N-18B	*N-18B-75	N-18B-BK	1-1/8 [28.6]	31/32 [24.6]

*PARTS AVAILABLE BY SPECIAL ORDER ONLY

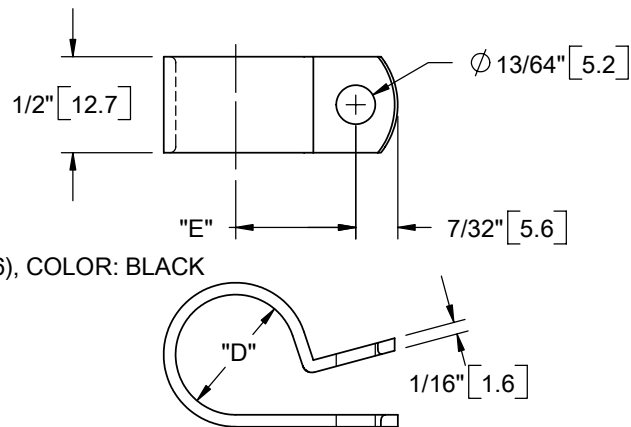

NOTES:

- MATERIAL: NYLON 6/6 UL 94 V-2, UV STABILIZED, (RMS-46), COLOR: BLACK AVAILABLE BY SPECIAL ORDER ONLY. TO ORDER ADD "-UVB" TO PART NO.

TITLE: CABLE CLAMPS, NB SERIES					DWG IN IN [MM]	
CREATED USING SOLIDWORKS	FILE #: NB	DWN: SK	APP: SK	FINAL		
TOLERANCES UNLESS NOTED .XX=±.010 .XXX=±.005 FRAC.=±1/64 ANG.=±1°	SHEET: 1 OF 1	SHEET SIZE: A	DT: 09/13/06	CHKD: SJ	PART #	PRINT TYPE
M	SEE ECN #1215 FOR CHANGES	SK	09/13/06		SEE TABLE	CA
-	SEE ENGINEERING FOR REV A-L	-	----			
REV.	DESCRIPTION	ENGR.	DATE			
RE: RICHCO, INC.				RICHCO, INC. ENG@RICHCO-INC.COM (773) 539-4060		