

Part Number

Description

[KKU-6-RT](#)

Clip,U Style,Adh Mnt,Grey,3/8" Hold



PART NO.	HOLDING CAPACITY "A"	"B" ±.015(0.4)	"C" ±.02 (±0.5)	"D" AT MAX CAPACITY REF.
KKU-2-RT	1/8 (3.2)	3/4 (19.1)	3/4 (19.1)	9/32 (7.1)
KKU-4-RT	1/4 (6.4)			15/32 (11.9)
KKU-6-RT	3/8 (9.5)			19/32 (15.1)
KKU-8-RT	1/2 (12.7)	1 (25.4)	1 (25.4)	11/16 (17.5)
KKU-9-RT	9/16 (14.3)			3/4 (19.1)
KKU-12-RT	3/4 (19.1)			29/32 (23.0)
KKU-14-RT*	7/8 (22.2)			31/32 (24.6)

*AVAILABLE BY SPECIAL ORDER ONLY

NOTES:

- MATERIAL: RIGID PVC (RMS-04).
AVAILABLE IN CLEAR PVC (RMS-32) BY SPECIAL ORDER.
- COLOR: GRAY
- TAPE: 1/16" THICK DOUBLE SIDED ADHESIVE (RMS-15), WHITE LINER.
- CUSTOM LENGTHS AVAILABLE BY SPECIAL ORDER.
- PARTS ALSO AVAILABLE WITHOUT THE ADHESIVE BY SPECIAL ORDER. TO ORDER REMOVE ""-RT" FROM THE PART NO.

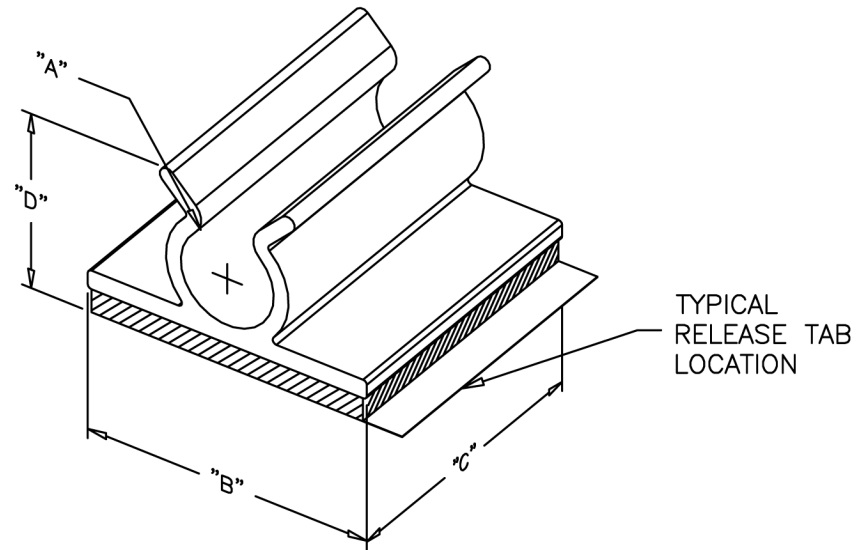

F	SEE CO 200133 FOR CHANGES	SK 02.26.08	TITLE: KWIK-KLIP, TYPE "U"				DWG IN IN(MM)	
E	SEE ECN #1130 FOR CHANGES	SJ 2.26.06					FINAL	
D	SEE ECN #491 FOR CHANGES	SM 10.16.02	TOLERANCES UNLESS NOTED	FILE # KKU	DWN: S.M.	APP:		
C	EDITED NOTE 1 & ADDED NOTE 4	SJ 03.14.02	.XX=±.020	MAT'L: SEE NOTES	DT: 11/20/00	DT:	PART #	PRINT TYPE
B	COMPLETELY RE-DRAWN & CHANGED FILE #	S.M.11.20.00	.XXX=±.015	RE: RICHCO INC.	RICHCO INC.		SEE TABLE	
A	ADDED NOTES, CORRECTED TAPE THICKNESS TO 1/16"	JK 2.10.00	FRAC=±1/64					
REV	DESCRIPTION	ENGR DATE	ANG=±1'					