

**See "Part Drawing" for Details**

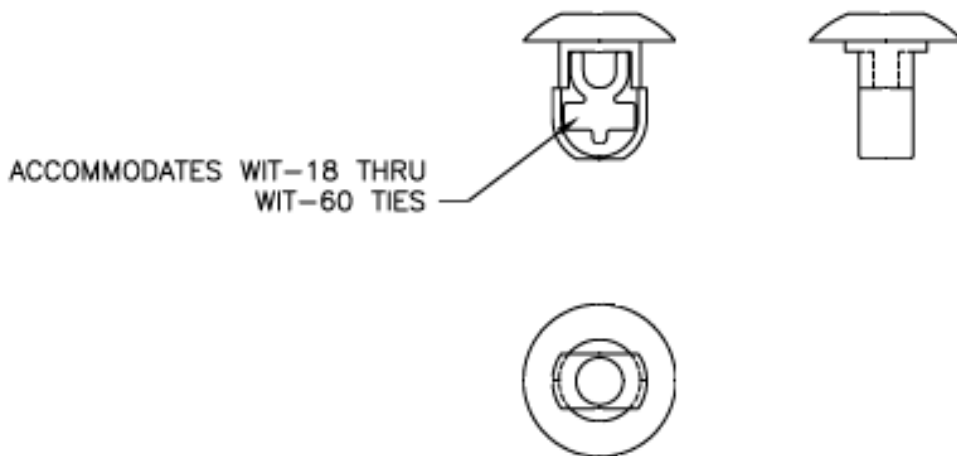

| Part Number                | Description  |
|----------------------------|--|
| <a href="#">FTH-9-01-M</a> | Cbl Tie Hldr,Arrow Mnt,Natural  |

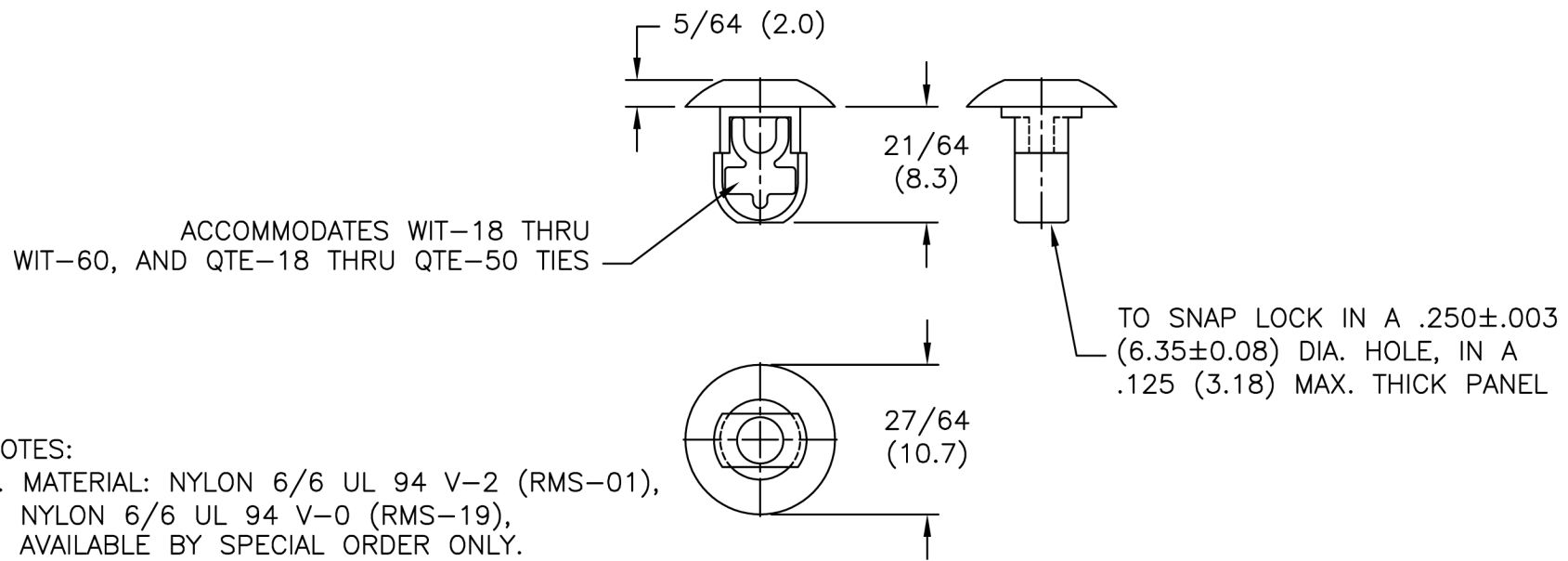

NOTES:

1. MATERIAL: NYLON 6/6 UL 94 V-2 (RMS-01),  
 NYLON 6/6 UL 94 V-0 (RMS-19),  
 AVAILABLE BY SPECIAL ORDER ONLY.  
 COLOR: NATURAL.
2. MATERIAL: UV STABILIZED NYLON (RMS-46),  
 COLOR BLACK.  
 AVAILABLE BY SPECIAL ORDER.  
 TO ORDER REPLACE "-01" WITH "-UVB"

|                        |                           |               |  |                  |              |      |            |    |  |
|------------------------|---------------------------|---------------|--|------------------|--------------|------|------------|----|--|
| TITLE: FLAT TIE HOLDER |                           |               | DWG IN IN (MM)   |                  | FINAL        |      |            |    |  |
| E                      | SEE CO 200091 FOR CHANGES | SK 12.18.07   | TOLERANCES UNLESS NOTED<br>.XX= $\pm .010$<br>.XXX= $\pm .005$<br>FRAC= $\pm 1/64$<br>ANG= $\pm 1^\circ$ | FILE # FTH-9     | DWN: P.B.    | APP: | PART #     |    |  |
| D                      | SEE ECN #1124 FOR CHANGES | SK 01.24.06   |  | MAT'L: SEE NOTES | DT: 06-29-94 | DT:  | FTH-9-01   |    |  |
| C                      | CHANGED FILE NO.          | SM 05.17.02   |  | RE: RICHCO, INC. | RICHCO INC.  |      | PRINT TYPE |    |  |
| B                      | FR NYLON (RMS-19) ADDED   | J.L. 01.07.00 |  |                  |              |      |            | CA |  |
| A                      | CONVERTED TO ACAD         | PB 06.29.94   |  |                  |              |      |            |    |  |
| REV                    | DESCRIPTION               | ENGR DATE     |  |                  |              |      |            |    |  |