

See "Part Drawing" for Details

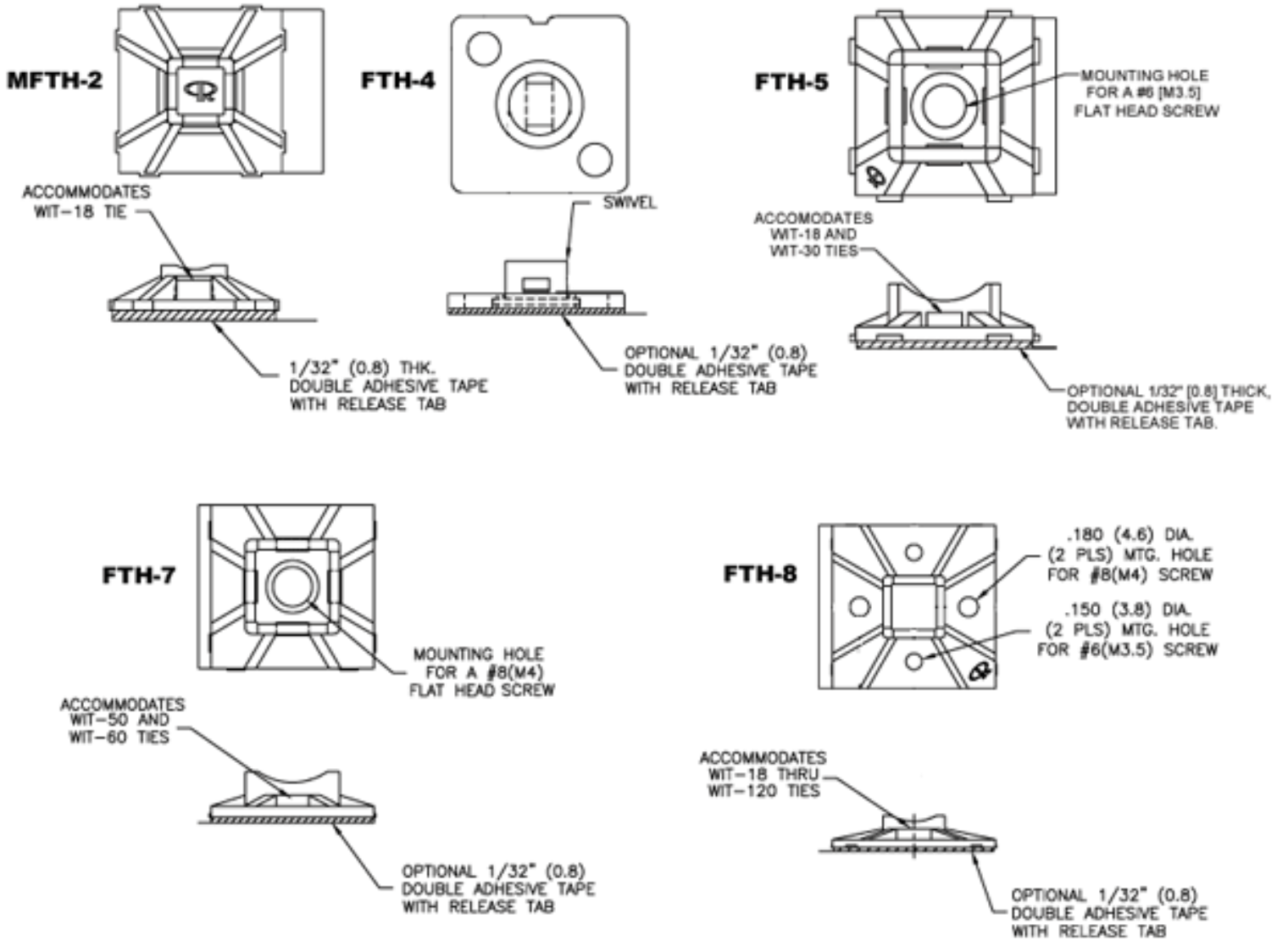

Part Number

Description

[FTH-7A-RT-C](#)

Cbl Tie Hldr,Adh Mnt,Natural,1x1"



PART NO.	MATERIAL	COLOR	ADHESIVE
FTH-7-01	NYLON 6/6 (RMS-01)	NATURAL	NONE
FTH-7A-RT			ACRYLIC TAPE (RMS-15), WHITE LINER
FTH-7A1-RT			RUBBER TAPE (RMS-102), BLUE LINER
FTH-7-UVB	*UVB NYLON (RMS-46)	BLACK	NONE
FTH-7A-RT-UVB			ACRYLIC TAPE (RMS-15), WHITE LINER

*UVB=UV STABILIZED NYLON, BLACK (RMS-46)

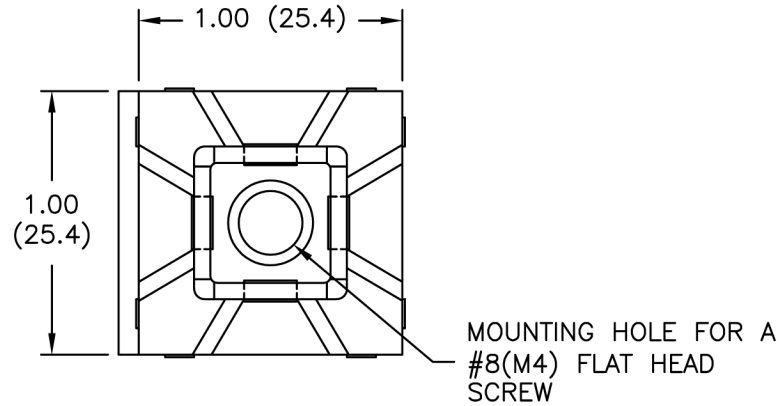

ACCOMMODATES WIT-50,
WIT-60, AND QTE-50 TIES

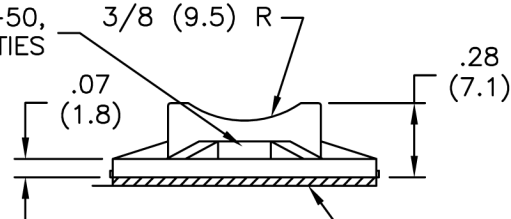

OPTIONAL 1/32" (0.8)
DOUBLE ADHESIVE TAPE
WITH RELEASE TAB

NOTES:

1. FLAME RETARDANT NYLON (RMS-19),
COLOR: NATURAL,
ACRYLIC ADHESIVE TAPE (RMS-15), WHITE LINER,
AVAILABLE BY SPECIAL ORDER ONLY;
TO ORDER USE P/N: FTH-7A-RT-19
OR FTH-7-19 (WITHOUT TAPE).

TITLE: FLAT TIE HOLDER			DWG IN IN (MM)		FINAL			
E	SEE ECN #1124 FOR CHANGES	SK 01.24.06	TOLERANCES UNLESS NOTED	FILE # FTH-7	DWN: P.B.	APP:	PART #	
D	COMPLETELY RE-DRAWN & CHANGED FILE#	SM 10.18.01	.XX=±.010	MAT'L: SEE NOTES	DT: 03-22-94	DT:	SEE TABLE	
C	RUBBER TAPE (RMS-102) ADDED	JL 08.22.00	.XXX=±.005	RE: RICHCO, INC.	RICHCO INC.		PRINT TYPE	
B	MAT'L NOTES UPDATED	JL 01.10.00	FRAC=±1/64					CA
A	CONVERTED TO ACAD	PB 03.22.94	ANG=±1°					
REV	DESCRIPTION	ENGR DATE						