

See "Part Drawing" for Details

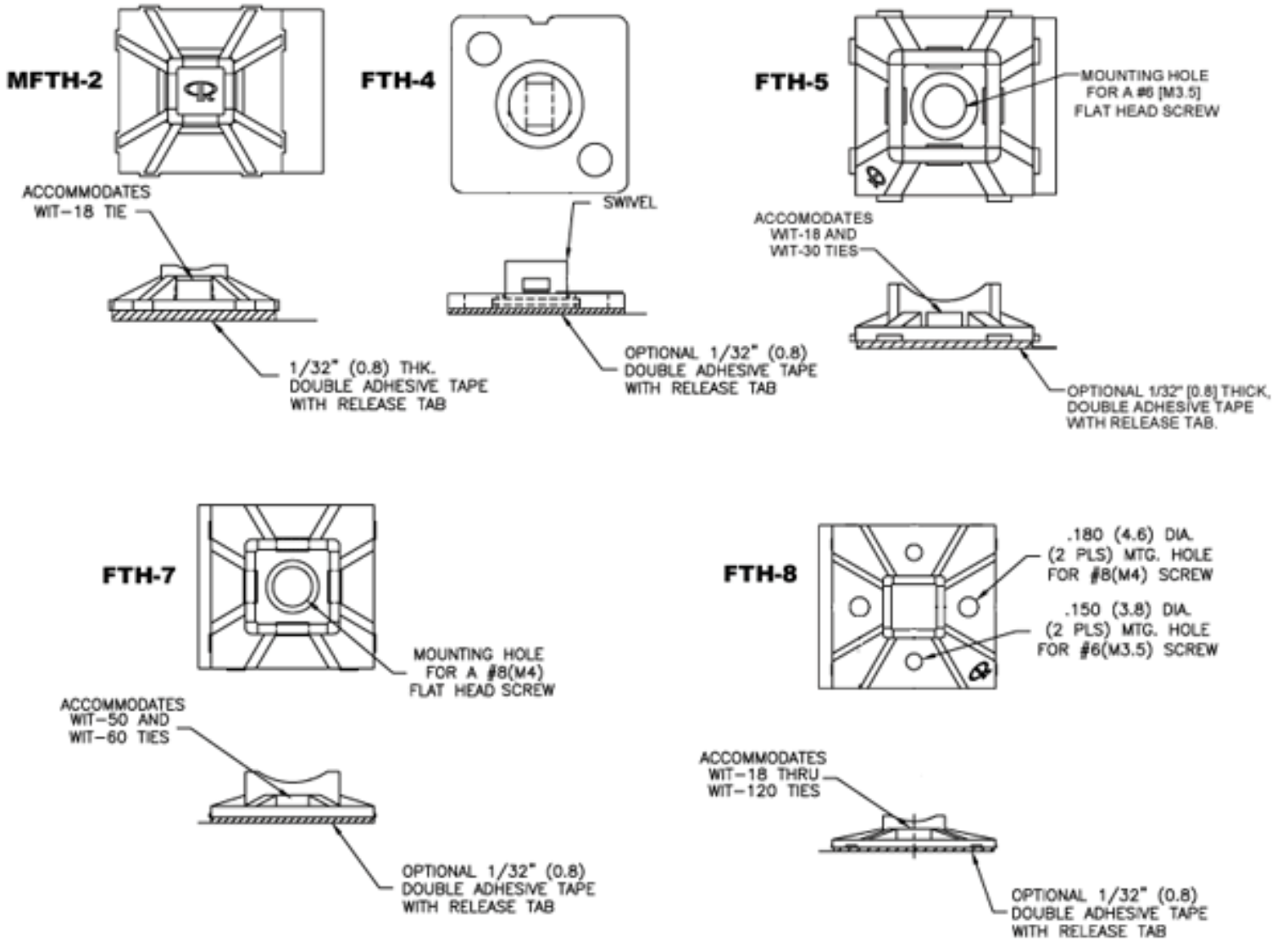

Part Number

Description

[FTH-5-01-C](#)

Cbl Tie Hldr, Screw Mnt, Nat., .75"



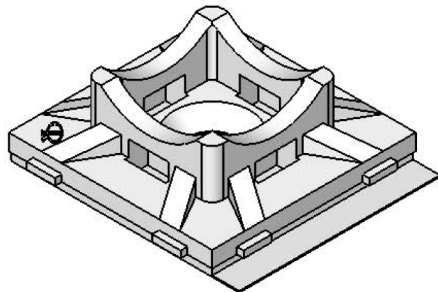

PART NO.	MATERIAL	COLOR	ADHESIVE
FTH-5-01	NYLON 6/6 (RMS-01)	NATURAL	NONE
FTH-5A-RT			ACRYLIC TAPE (RMS-15), WHITE LINER
FTH-5A1-RT			RUBBER TAPE (RMS-102), BLUE LINER
FTH-5-UVB	UVB STABILIZED NYLON (RMS-46)	BLACK	NONE
FTH-5A-RT-UVB			ACRYLIC TAPE (RMS-15), WHITE LINER
*FTH-5A1-RT-UVB			RUBBER TAPE (RMS-102), BLUE LINER

*AVAILABLE BY SPECIAL ORDER ONLY

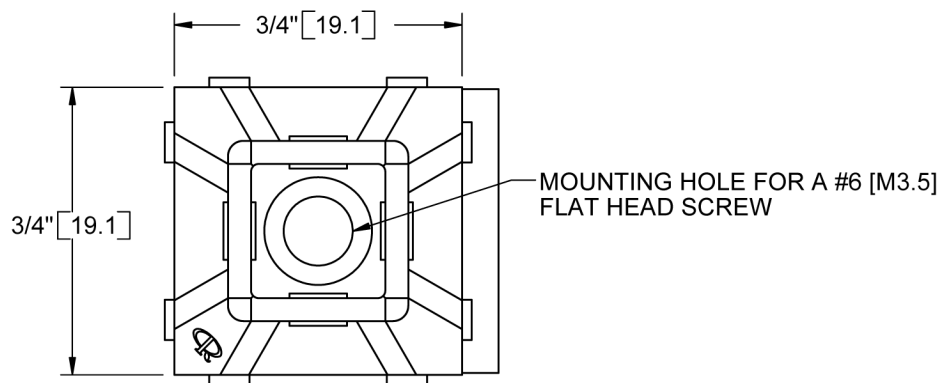

ACCOMODATES
WIT-18, WIT-30, AND QTE-18 TIES

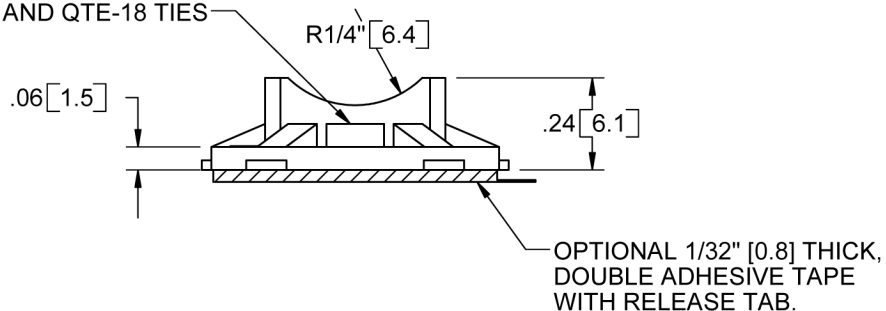

NOTES:
1. MATERIAL: FLAME RETARDANT NYLON 6/6 (RMS-19)
COLOR NATURAL.
AVAILABLE BY SPECIAL ORDER ONLY.

TITLE: FLAT TIE HOLDER				DWG IN IN [MM]		FINAL	
CREATED USING SOLIDWORKS	FILE #: FTH-5	DWN: SK	APP: -				
TOLERANCES UNLESS NOTED .XX=±.010 .XXX=±.005 FRAC.=±1/64 ANG.=±1°	SHEET: 1 OF 1	SHEET SIZE: A	DT: 03/10/05	CHKD: -	PART #		PRINT TYPE
	RE: RICHCO, INC.	RICHCO, INC.		SEE TABLE		CA	

REV.	DESCRIPTION	ENGR.	DATE
G	SEE ECN #1124 FOR CHANGES	SK	01/24/06
F	SEE ECN #962 FOR CHANGES	SK	03/10/05
-	SEE ENGINEERING FOR REV. A-E	-	----