

See "Part Drawing" for Details



**Part Number**

[AFCC-21](#)

**Description**

Clamp,Flat,Adh Mnt,Alum,1-5/16" Wd



PART NO.	CABLE WIDTH "A"	DIM "B"	DIM "C"
AFCC-08	1/2 (12.7)	1/4 (6.4)	.02 (0.5)
AFCC-12	3/4 (19.1)	1/4 (6.4)	
AFCC-16	1 (25.4)	5/16 (7.9)	
AFCC-20	1-1/4 (31.8)	3/8 (9.5)	
AFCC-21	1-5/16 (33.3)	.385 (9.8)	
AFCC-24	1-1/2 (38.1)	7/16 (11.1)	
AFCC-28	1-3/4 (44.5)	1/2 (12.7)	.03 (0.7)
AFCC-32	2 (50.8)	9/16 (14.3)	
AFCC-44	2-3/4 (69.9)	3/4 (19.1)	
AFCC-48	3 (76.2)	13/16 (29.6)	

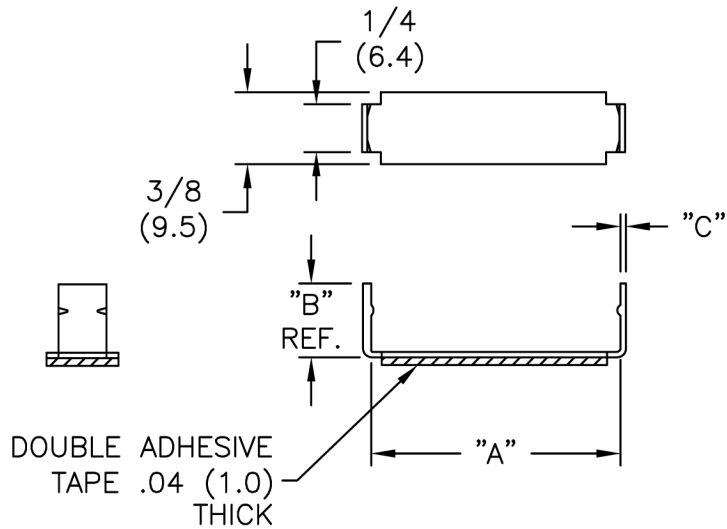

NOTES:

1. MATERIAL: ALUMINUM (RMS-194)
2. ADHESIVE: RUBBER (RMS-34)

TITLE: ALUMINUM FLAT CABLE CLAMP			DWG IN IN (MM)		FINAL		PRINT TYPE	
D	SEE CO 200041 FOR CHANGES	SK 09.28.07	FILE # AFCC	DWN: P.B.	APP:	PART #		CA
C	SEE ECN #1276 FOR CHANGES	SK 01.22.07	MAT'L: SEE NOTES	DT: 01-16-95	DT:	SEE TABLE		
B	CHANGED FILE NO. AND TITLE BLOCK	SM 03.22.02	RE: RICHCO, INC.	RICHCO INC.				
A	CONVERTED TO ACAD	PB 01.16.95						
REV	DESCRIPTION	ENGR DATE						

TOLERANCES  
UNLESS NOTED  
.XX=±.010  
.XXX=±.005  
FRAC=±1/64  
ANG=±1°

