

# 9234S006

Lo-Cog® DC Motor



Assembly Data	Symbol	Units	Value	
Reference Voltage	E	V	24	
No-Load Speed	S <sub>NL</sub>	rpm (rad/s)	6,151	(644)
Continuous Torque (Max.) <sup>1</sup>	T <sub>C</sub>	oz-in (N-m)	6.1	(4.3E-02)
Peak Torque (Stall) <sup>2</sup>	T <sub>PK</sub>	oz-in (N-m)	41	(2.9E-01)
Weight	W <sub>M</sub>	oz (g)	10	(286)
Motor Data				
Torque Constant	K <sub>T</sub>	oz-in/A (N-m/A)	5.17	(3.65E-02)
Back-EMF Constant	K <sub>E</sub>	V/krpm (V/rad/s)	3.82	(3.65E-02)
Resistance	R <sub>T</sub>	Ω	2.96	
Inductance	L	mH	2.51	
No-Load Current	I <sub>NL</sub>	A	0.16	
Peak Current (Stall) <sup>2</sup>	I <sub>P</sub>	A	8.11	
Motor Constant	K <sub>M</sub>	oz-in/√W (N-m/√W)	3.01	(2.13E-02)
Friction Torque	T <sub>F</sub>	oz-in (N-m)	0.60	(4.2E-03)
Rotor Inertia	J <sub>M</sub>	oz-in-s <sup>2</sup> (kg-m <sup>2</sup> )	5.9E-04	(4.2E-06)
Electrical Time Constant	τ <sub>E</sub>	ms	0.85	
Mechanical Time Constant	τ <sub>M</sub>	ms	9.3	
Viscous Damping	D	oz-in/krpm (N-m-s)	0.039	(2.6E-06)
Damping Constant	K <sub>D</sub>	oz-in/krpm (N-m-s)	6.7	(4.5E-04)
Maximum Winding Temperature	θ <sub>MAX</sub>	°F (°C)	311	(155)
Thermal Impedance	R <sub>TH</sub>	°F/watt (°C/watt)	62.8	(17.1)
Thermal Time Constant	τ <sub>TH</sub>	min	12.0	
Gearbox Data				
Encoder Data				

**Included Features**

- 2-Pole Stator
- Ceramic Magnets
- Heavy-Gauge Steel Housing
- 7-Slot Armature
- Silicon Steel Laminations
- Stainless Steel Shaft
- Copper-Graphite Brushes
- Diamond Turned Commutator
- Motor Ball Bearings

---

**Customization Options**

- Alternate Winding
- Sleeve or Ball Bearings
- Modified Output Shaft
- Custom Cable Assembly
- Special Brushes
- EMI/RFI Suppression
- Spur or Planetary Gearbox
- Special Lubricant
- Optional Encoder
- Fail-Safe Brake

1 - Specified at max. winding temperature at 25°C ambient without heat sink. 2 - Theoretical values supplied for reference only.

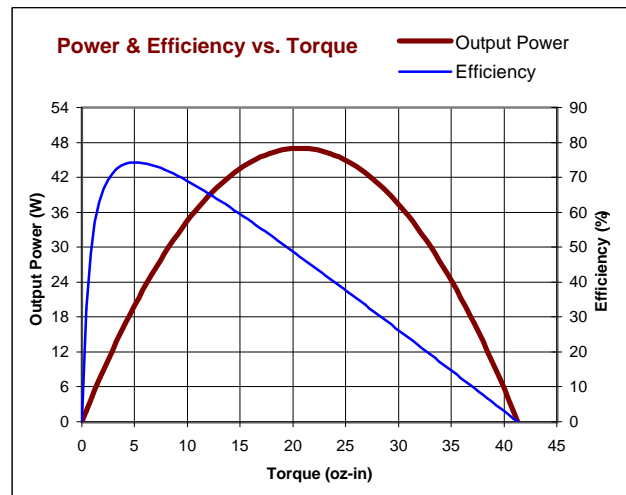
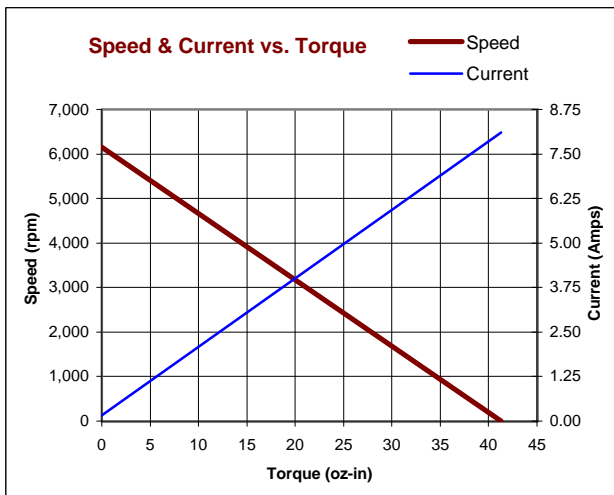

All values are nominal. Specifications subject to change without notice. Graphs are shown for reference only.

© 2001 Pittman.

NOTICE: CONFIDENTIAL PROPRIETARY INFORMATION THIS PRINT CONTAINS IDEAS, INFORMATION, AND INTELLECTUAL PROPERTY WHICH ARE THE EXCLUSIVE PROPERTY OF PITTMAN, DIVISION OF PENN ENGINEERING & MANUFACTURING CORP. RECIPIENT MUST KEEP THE INFORMATION DISCLOSED HEREIN CONFIDENTIAL AND RECIPIENT IS EXPRESSLY PROHIBITED FROM COPYING OR PUBLICATION OF THIS PRINT EXCEPT TO OTHERS IN THEIR ORGANIZATION ON A NEED-TO-KNOW BASIS.

REVISIONS				
LTR	DESCRIPTION	DRFT/ENGR	DATE	APPR
D	REDRAWN & REVISED	RJS/RJS	3/20/96	JRM
E	1/4" STRIP & TIN WAS "STRIP"	KUH/KUH		

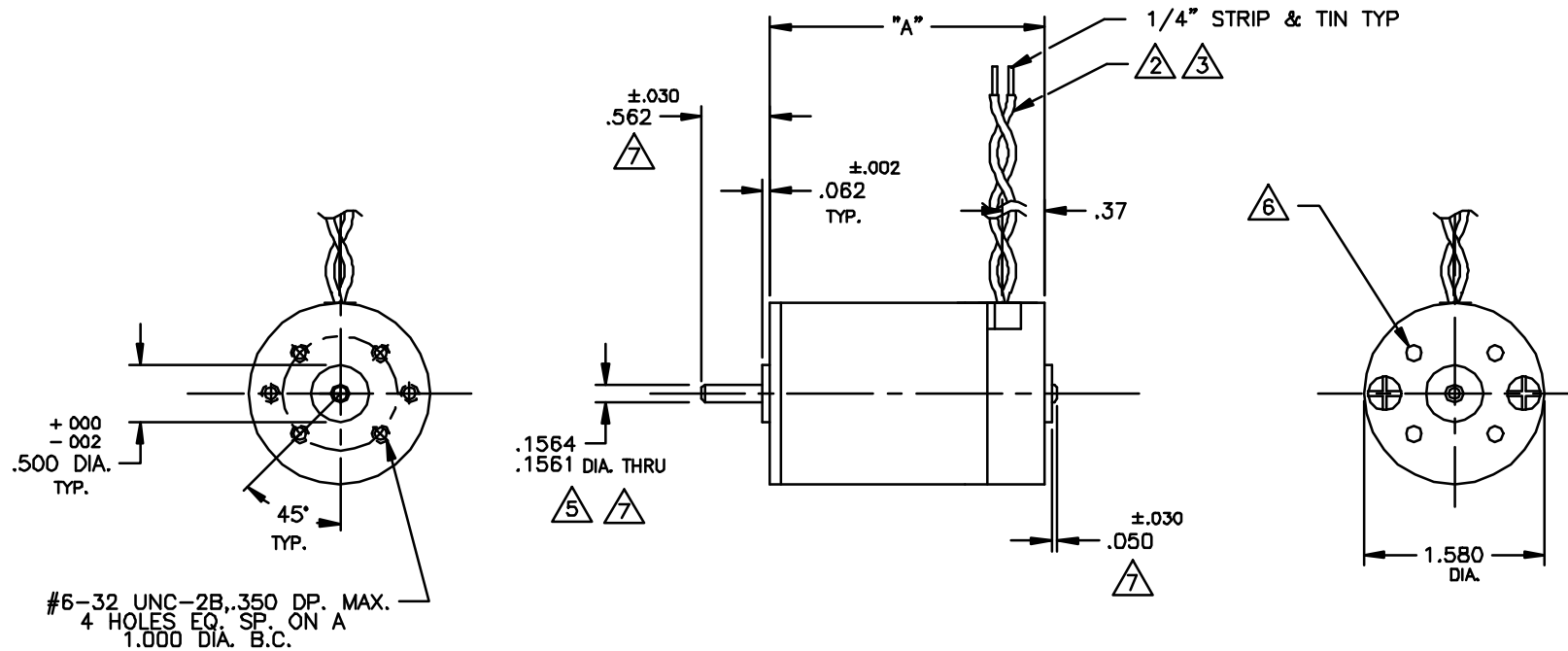

#6-32 UNC-2B,.350 DP. MAX.  
4 HOLES EQ. SP. ON A  
1.000 DIA. B.C.

NOTES:

- SHAFT ROTATION IS CW VIEWING MOUNTING END WITH POSITIVE (+) VOLTAGE APPLIED TO RED LEAD.
- LEADS ARE 22 AWG (7X30) PVC INSULATION, UL STYLE 1569/1007. RED AND BLACK
- STANDARD LEAD LENGTH IS  $18" \pm 1/2"$
- ENDPLAY-.015 MAX. FOR SLEEVE BEARING MOTORS. BALL BEARING MOTORS ARE PRE-LOADED PER SPEC. P-107
- OPTIONAL SHAFT DIA.  $.1246/.1243$  IS AVAILABLE ONLY WITH THE 94X2 AND 94X3 MOTOR LENGTHS.
- OPTIONAL REAR ENDBELL MOUNTING PATTERN #6-32 UNC-2B,  $.180$  MAX THREAD PENETRATION, 4 HOLES EQ. SP. ON A  $1.000$  DIA B.C.
- ALL SHAFT DIMENSIONS NOTED ARE STANDARD (10-631-00); FOR ALL OTHER SHAFT CONFIGURATIONS REFER TO DATA SHEET FOR PART #'S

3.053	92X6
2.703	92X5
2.403	92X4
2.203	92X3
1.828	92X2
"A" MAX	MODEL No.

UNLESS OTHERWISE SPECIFIED DIMENSIONS ARE IN INCHES TOLERANCES ARE: FRACTION DECIMAL ANGLES $\pm 1/84$ $\pm .015$ $\pm 1^\circ$ $\pm .010$ $\pm .005$		FILE:		
BREAK ALL SHARP EDGES		DRAFTED BY: RJS	DATE: 3/20/95	<b>TITLE:</b> OUTLINE AND MTG. DIMS. 92XX SERIES MOTOR
MATERIAL:		ENGINEERED BY: RJS	APPROVED BY:	
FINISH:		NEXT ASSY:		<b>DWG. NO.</b> B- 150-409
		USED ON:		<b>SCALE:</b> NONE <b>SHEET</b> 1
				<b>REV.</b> E