



GM8724S018

Lo-Cog® DC Gearmotor

| Assembly Data | Symbol | Units | Value | |
|---------------------------------------|------------------|---|---------|------------|
| Reference Voltage | E | V | 12 | |
| No-Load Speed | S _{NL} | rpm (rad/s) | 146 | (15.3) |
| Continuous Torque (Max.) ¹ | T _C | oz-in (N-m) | 61 | (4.3E-01) |
| Peak Torque (Stall) ² | T _{PK} | oz-in (N-m) | 168 | (1.2E+00) |
| Weight | W _M | oz (g) | 8.4 | (239) |
| Motor Data | | | | |
| Torque Constant | K _T | oz-in/A (N-m/A) | 3.09 | (2.18E-02) |
| Back-EMF Constant | K _E | V/krpm (V/rad/s) | 2.29 | (2.18E-02) |
| Resistance | R _T | Ω | 4.33 | |
| Inductance | L | mH | 2.34 | |
| No-Load Current | I _{NL} | A | 0.18 | |
| Peak Current (Stall) ² | I _P | A | 2.77 | |
| Motor Constant | K _M | oz-in/√W (N-m/√W) | 1.49 | (1.05E-02) |
| Friction Torque | T _F | oz-in (N-m) | 0.35 | (2.5E-03) |
| Rotor Inertia | J _M | oz-in-s ² (kg-m ²) | 2.3E-04 | (1.6E-06) |
| Electrical Time Constant | τ _E | ms | 0.54 | |
| Mechanical Time Constant | τ _M | ms | 14.7 | |
| Viscous Damping | D | oz-in/krpm (N-m-s) | 0.020 | (1.4E-06) |
| Damping Constant | K _D | oz-in/krpm (N-m-s) | 1.6 | (1.1E-04) |
| Maximum Winding Temperature | θ _{MAX} | °F (°C) | 311 | (155) |
| Thermal Impedance | R _{TH} | °F/watt (°C/watt) | 70.5 | (21.4) |
| Thermal Time Constant | τ _{TH} | min | 10.7 | |
| Gearbox Data | | | | |
| Reduction Ratio | | | 30.9 | |
| Efficiency ³ | | | 0.80 | |
| Maximum Allowable Torque | | oz-in (N-m) | 175 | (1.24) |
| Encoder Data | | | | |
| | | | | |
| | | | | |

1 - Specified at max. winding temperature at 25°C ambient without heat sink. 2 - Theoretical values supplied for reference only.
 3 - Effective gearbox efficiency for this unit improved by use of ball bearings.

- ### Included Features
- 2-Pole Stator
 - Ceramic Magnets
 - Heavy-Gauge Steel Housing
 - 7-Slot Armature
 - Silicon Steel Laminations
 - Stainless Steel Shaft
 - Copper-Graphite Brushes
 - Diamond Turned Commutator
 - Motor Ball Bearings
 - Output Ball Bearing
 - Wide Face Gears

- ### Customization Options
- Alternate Winding
 - Sleeve or Ball Bearings
 - Modified Output Shaft
 - Custom Cable Assembly
 - Special Brushes
 - EMI/RFI Suppression
 - Alternate Gear Material
 - Special Lubricant
 - Optional Encoder
 - Fail-Safe Brake

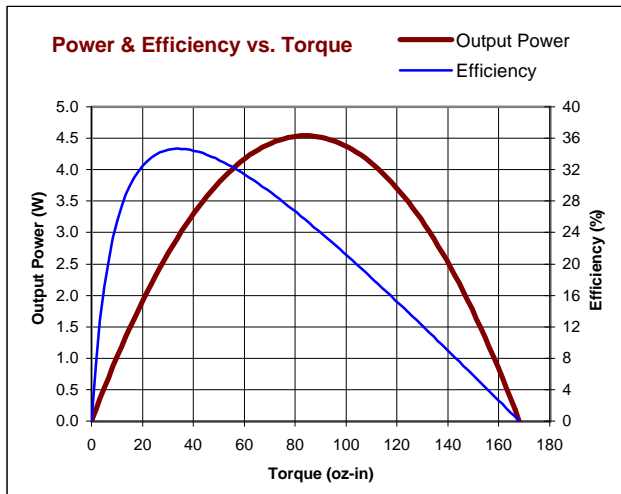
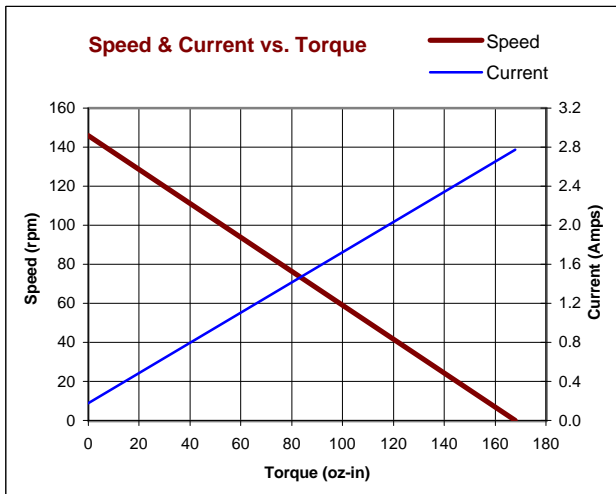

All values are nominal. Specifications subject to change without notice. Graphs are shown for reference only.

© 2001 Pittman.

NOTICE: CONFIDENTIAL PROPRIETARY INFORMATION THIS PRINT CONTAINS IDEAS, INFORMATION, AND INTELLECTUAL PROPERTY WHICH ARE THE EXCLUSIVE PROPERTY OF PITTMAN, DIVISION OF PENN ENGINEERING & MANUFACTURING CORP. RECIPIENT MUST KEEP THE INFORMATION DISCLOSED HEREIN CONFIDENTIAL AND RECIPIENT IS EXPRESSLY PROHIBITED FROM COPYING OR PUBLICATION OF THIS PRINT EXCEPT TO OTHERS IN THEIR ORGANIZATION ON A NEED-TO-KNOW BASIS

| REVISIONS | | | | |
|-----------|----------------------------------|-----------|---------|------|
| LTR | DESCRIPTION | DRFT/ENGR | DATE | APPR |
| H | REDRAWN, UPDATED TO CURRENT STD. | DLF | 6/28/94 | JVM |
| J | UPDATED TO CURRENT STD. | RJS/RJS | | |

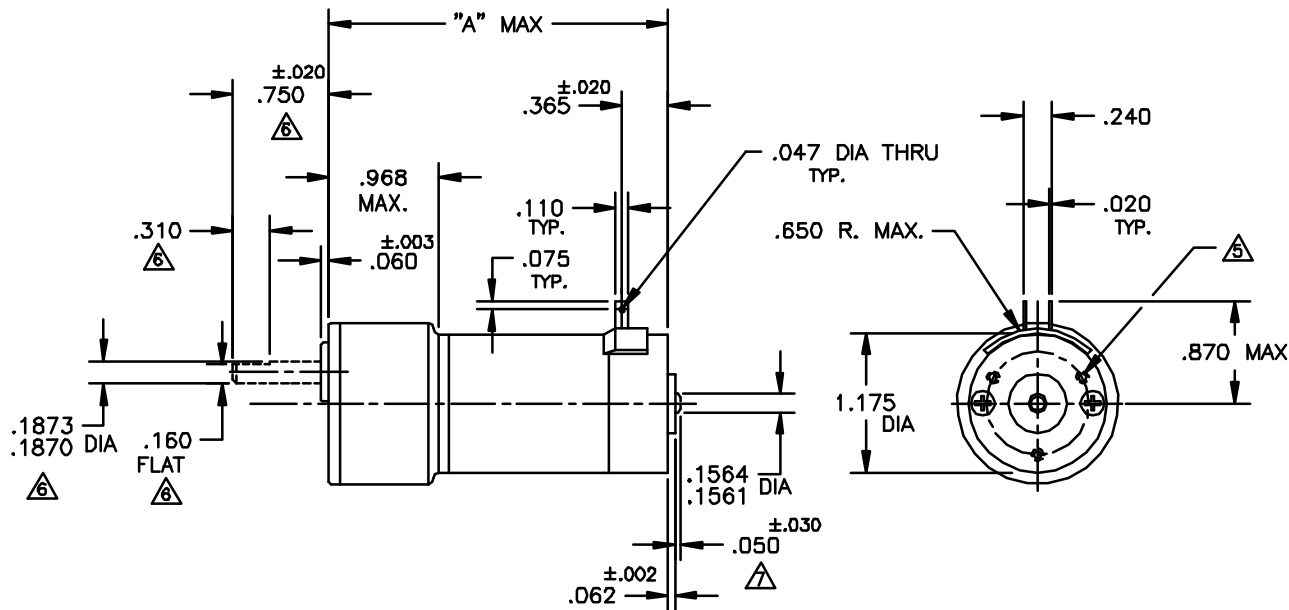
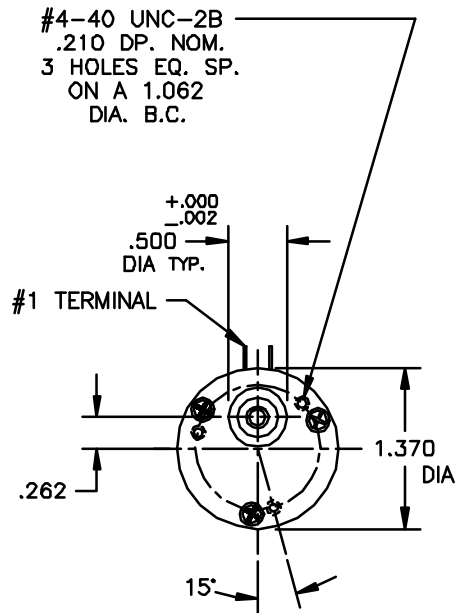

NOTES:

- SHAFT ROTATION IS SHOWN WHILE VIEWING MOUNTING END, WITH POSITIVE (+) VOLTAGE APPLIED TO # 1 TERMINAL.
 - TERMINALS ARE PLATED FOR SOLDERING.
 - MAX. GEARBOX TORQUE RATING IS 100 OZ.IN., STANDARD SINTERED GEARS. MAX. GEARBOX TORQUE RATING IS 160 OZ.IN., CUT STEEL GEARS.
 - ENDPLAY .020 MAX. ON OUTPUT SHAFT, .015 MAX. ON MOTOR SHAFT.
- △ OPTIONAL MOUNTING PATTERN #2-56 UNC-2B, (3) HOLES EQUALLY SPACED ON A .875 DIA. B.C., .125 MAX. THREAD DEPTH.
- △ ALL SHAFT DIMENSIONS SHOWN ARE STD. (10-385). FOR ALL OTHER CONFIGURATIONS REFER TO DATA SHEET FOR PART NUMBERS.
- △ OPTIONAL REAR SHAFT EXTENSIONS AVAILABLE.

| GEAR RATIO | DIRECTION | | |
|------------|-----------|----------|-----------|
| 187/96:1 | CCW | 3.285 | GM87X4 |
| 60.5/31:1 | CW | 3.035 | GM87X3 |
| 19.5/10:1 | CCW | 2.910 | GM87X2 |
| 6.3:1 | CW | "A" MAX. | MODEL NO. |

| | | |
|--|----------------------------------|----------------------------|
| UNLESS OTHERWISE SPECIFIED DIMENSIONS ARE IN INCHES TOLERANCES ARE: FRACTION DECIMAL ANGLES ±1/64 .0015 ±1° XX ±0.015 XXX ±0.005 BREAK ALL SHARP EDGES | FILE: 150/28 | |
| | DRAFTED BY: DLF DATE: 6/24/94 | |
| MATERIAL: | ENGINEERED BY: DLF DATE: 6/24/94 | DWG. NO. 150-28 |
| FINISH: | APPROVED BY: JVM DATE: 6/28/94 | REV. J |
| | NEXT ASSY: | SCALE: D.N.S. SHEET 1 OF 1 |
| | USED ON: | |