

[Part Number Search](#)[Home](#)[Company Overview](#)[Products](#)[Technical Help](#)[Contact Us](#)[Order-On-Line,
Application Notes,
On-Line Services](#)**MOTORS**

[Brushless DC](#)
[Synchronous](#)
[Stepping](#)
[Hybrid Stepper](#)
[Induction](#)
[Brushed DC](#)
[Linear](#)

CONTROLLERS**CAPACITORS**

SYNCHRONOUS MOTOR FAMILY

Series A, AB Geared Synchronous Motor



These motors are among our most popular synchronous motors and are designed for heavy duty usage. The A and AB motors are widely used in computer peripheral equipment, chart drives, medical instruments and a great variety of industrial applications.

Standard motors are 115VAC for 60HZ operation. Other voltages and 50 Hz frequency may be specified. The motors are reversible, and output torque is up to 150 oz-in.

Standard and modified involute spur gearing is used in Motor Series beginning with the letters A, P, and T. All gears are hobbled to AGMA 7 quality. Pinions are extruded from special steel with a modified long addendum tooth form to provide higher strength. Pinions are held to the same AGMA 7 quality level as the gears. Both pinion and gear teeth are case hardened for wear resistance and rotate upon hardened and ground steel studs.

Output bearings are sintered bronze impregnated with synthetic E.P. oil. Other bearings are grease lubricated and are made from bearing grade phosphor bronze. Lubrication of the gear teeth and studs is provided by synthetic grease with extreme pressure qualities for long life.

Notes:

- Motors Listed below are 115V, 60 Hz models.
- Capacitors are required for operation and must be used in the circuit even if the motor is used in a unidirectional mode.

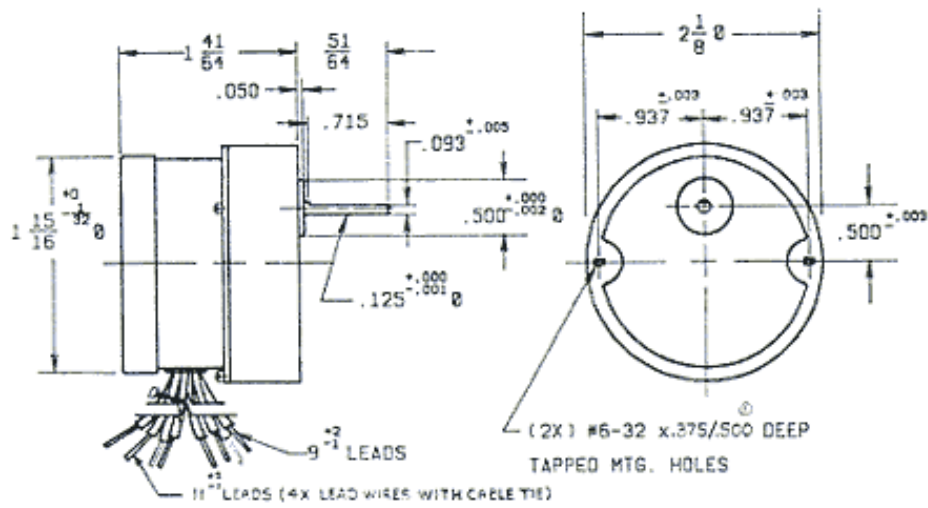

A, AB Geared

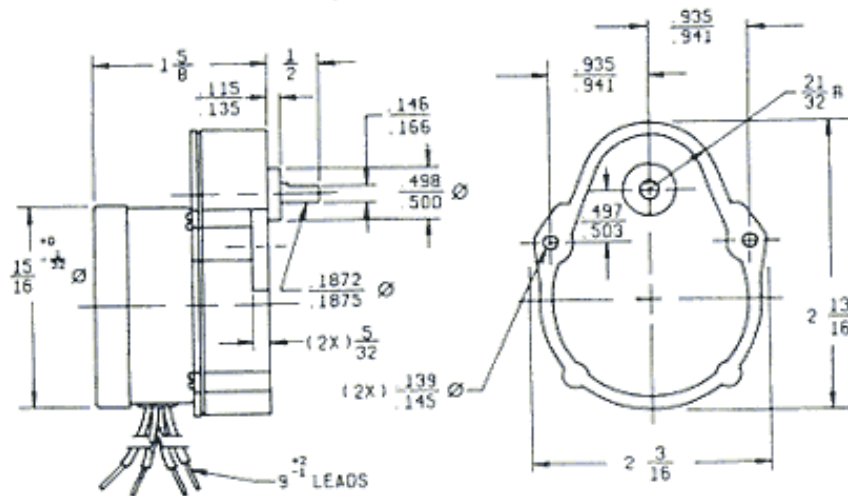

*Dimensions are in inches

WIRING DIAGRAM

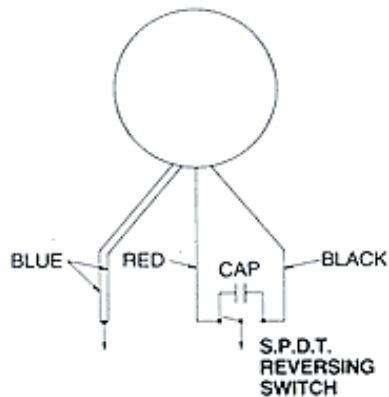

Current applied to the blue and red leads produces CW rotation. Switching the current to the blue and black leads produces CCW rotation.

[Change to Metric](#)

[View Printable Format \(Data Sheet\)](#)

[View Printable Format \(Parts Table\)](#)

To purchase one of the motors listed below, you must be logged into your MyHurst account, then simply click the part number to add the item to your Shopping Cart!

Model	Part Number	Reduction	Rated Torque @ 175 p/s (oz-in)	Holding Torque (oz-in)	Detent Torque (oz-in)	Output Speed (RPM)	Maximum gear train loading	Input Power (watts)	Voltage (VAC) 60HZ	Capacitor Value (mfd)	Shaft bearing	Weight (oz)
A	3002-005	75	110			4	X	3	115	0.25	sleeve	11