



SGABM20-A-C



- Low profile design keeps bundle close to mounting surface
- Small overall size allows use where space is limited
- Cable tie cross section sizes: SGM = Super-Grip™ Miniature, SGI = Super-Grip™ Intermediate, SGS = Super-Grip™ Standard, SGLH = Super-Grip™ Light Heavy, SGH = Super-Grip™ Heavy.

Part Number	SGABM20-A-C
RoHS Compliancy Status	Compliant
Part Description	Super Grip™ 4-Way Adhesive Backed Cable Tie Mount
Material	Nylon 6.6
Color	White
Height (In.)	.16
Height (mm)	4.0
Length (In.)	.75
Length (mm)	19.1
Width (In.)	.75
Width (mm)	9.1
Adhesive Type	Rubber
Environment	Indoor Use
Mounting Method	Rubber
Pricing Description	Super Grip Adhesive Mount, Adh., .75" x .75" (19.1mm x 19.1mm), NAT
Used With Cable Ties	SGM, SGI
Min. Order UOM	PC
Min. Order Qty.	100
BOM Qty. (# of Pkgs.)	

NO WARRANTY, EXPRESSED OR IMPLIED IS MADE BY PANDUIT WITH RESPECT TO ADHESIVE BOND PERFORMANCE. AMONG OTHER THINGS, THE CONDITIONS UNDER WHICH THESE MOUNTS MAY BE APPLIED AND / OR THE SURFACE TO WHICH THEY MAY BE APPLIED ARE BEYOND PANDUIT'S CONTROL.

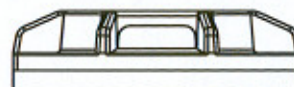
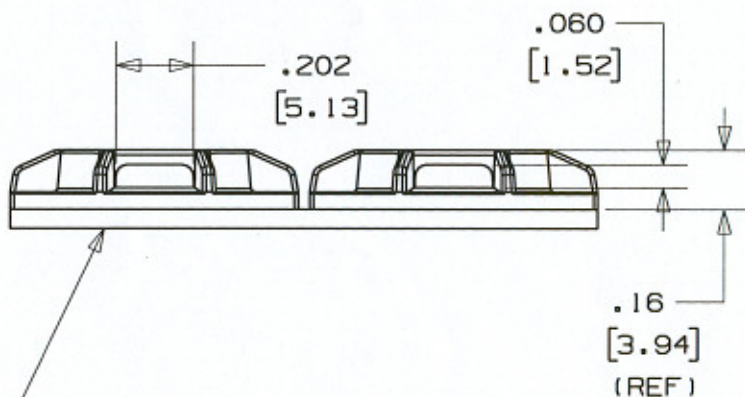
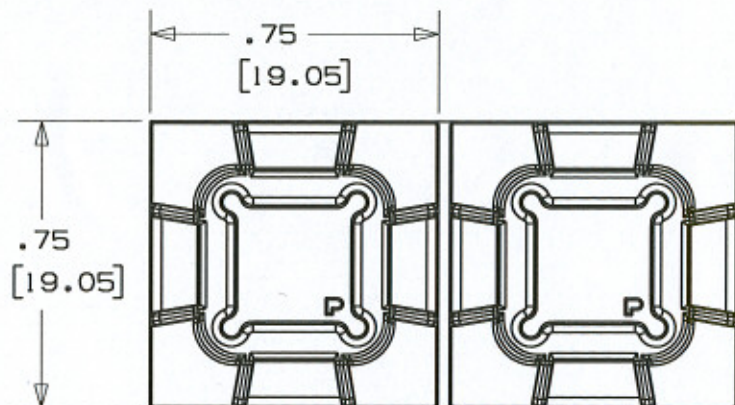

SCALE: FULL

ADHESIVE BACKING:

- *[-A] RUBBER BASED ADHESIVE PRESSURE SENSITIVE FOAM TAPE 0.04 (1.0) THICK WITH A PROTECTIVE LINER. MOUNT IS DESIGNED TO SUPPORT 0.28 lbs (127g) MAX. WEIGHT ON A CLEAN DRY SMOOTH SURFACE.
- *[-AT] ACRYLIC BASED ADHESIVE PRESSURE SENSITIVE FOAM TAPE 0.04 (1.0) THICK WITH A PROTECTIVE LINER. MOUNT IS DESIGNED TO SUPPORT 0.28 lbs (127g) MAX. ON A CLEAN DRY SMOOTH SURFACE.

PANDUIT PART NO. *	REC'M FASTENER	USE WITH THESE CABLE TIE CROSS SECTIONS	WEIGHT lbs / 100 (g) / pcs
SGABM20-A- ABM20 PAM075AB-A-	RUBBER ADHESIVE	M, I, SG100M, SG150I	0.142 (64.4)
SGABM20-AT- ABM20B PAM075AB-AT-	ACRYLIC ADHESIVE		

NOTES

- SEE CURRENT PRICE SHEET FOR PART NUMBER SUFFIX DESIGNATION FOR PACKAGE SIZE AND COLOR.
- PRODUCT IS SUPPLIED IN STRIPS OF TWO.
- [-A] MOUNT HAS A MAXIMUM CONTINUOUS OPERATING TEMPERATURE OF 120°F (49°C).
[-AT] MOUNT HAS A MAXIMUM CONTINUOUS OPERATING TEMPERATURE OF 180°F (82°C).

DIMENSIONS IN BRACKETS ARE METRIC (mm)

CAD FILENAME/LAYERS G03150FB_PB_SGABM20_00

PANDUIT CORP. TINLEY PARK, ILLINOIS

ADHESIVE BACKED MOUNT - SUPER GRIP COMPATIBLE (SGABM20-
20B); (PAM075AB-A, -AT)

UNLESS OTHERWISE SPECIFIED, DIMENSIONAL TOLERANCES ARE:
(.X) ±0.05 (1.3) (.XXX) ±0.010 (0.25)
(.XX) ±0.02 (0.5) ANGLES ±5°

UNLESS OTHERWISE SPECIFIED, ALL DIMENSIONS ARE GIVEN IN INCHES, THIRD ANGLE PROJECTION.

DRAWN BY JAD

MAT'L:

SCALE 2X

DATE 6/12/06

NYLON 6/6

DRAWING NO.

GB3150FB

DWG
A
SIZE

REV	DATE	BY	CHK	DESCRIPTION	ECN	R	CUST	SUP
R	6/12/06	JAD	SMY	INITIAL RELEASE	GB3150FB	R		