

Current refinements (click to remove)

[Search Tips](#) 
 [Region](#) **USA** [Product Family](#) **Ring Terminal, Nylon Insulated** [Text Search](#): 'PN18-8R-M'

Your search criteria matched only one product, shown below.

- Ring tongue design assures a secure connection in high vibration applications
- Metal insulation grip sleeve crimps to wire insulation, providing protection to the crimp joint during high vibration applications
- Internal barrel serrations assure good wire contact and maximum tensile strength
- UL Flammability UL 94V-2/HB, maximum insulation temperature 221°F (105°C)
- UL and CSA rated up to 600 V per UL 486

‡UL and CSA approved tooling/product combinations.

Note: Wire sizes #26 – #22 AWG, are not UL Listed or CSA Certified.

Related Products
[Hand Operated Plier Type Tools](#)
[Contour Crimp™ Control...](#)
[Pneumatic Crimping Tool](#)

Part Number:	PN18-8R-M
RoHS Compliancy Status:	Compliant
Part Description:	Ring Terminal, 22 – 18 AWG, #8 stud size, nylon insulated.
Product Type:	Terminals
CSA Certified:	Yes
Mil. Std. Part Number:	MS25036-149 (Class 1 & 2)
UL Listed:	Yes
Length (In.):	.86
Length (mm):	21.8
Width (In.):	.31
Width (mm):	7.87
Angle:	straight
Clearance:	.25
Max. Ins.:	.145
Panduit Color Code:	Red
Stock:	.03
Stud Size:	#8
Tool:	CT-100A‡, CT-600-A‡, CT-1550‡, CT-1551‡, CT-2500‡
Wire Range:	22 – 18 AWG
Wire Range (mm²):	4.0 - 6.0
Min. Order UOM:	PC
Min. Order Qty.:	1000
BOM Qty. (# of Pkgs.)	

[Add to My Catalog](#)

 Please [register](#) to utilize the 'Bill of Materials', 'Submit Quotes' and 'My Catalog' features.

PANDUIT PART NUMBER PREFIX	PK	MILITARY PART NO. AND CLASS	STUD SIZE	DIMENSIONS in.				
				A ±.03	W ±.01	C ±.02	G ±.03	H ±.01
PN18-4R	-C -M	-----	#4	.80 (20.3)	.25 (6.4)	.22 (5.6)	.67 (17.0)	.12 (3.1)
PN18-4RN	-C -M	MS25036-148 CLASS 1 & 2	#4	.74 (18.8)	.22 (5.6)	.18 (4.6)	.63 (16.0)	.12 (3.1)
PN18-6R	-C -M	MS25036-102 CLASS 1 & 2	#6	.80 (20.3)	.25 (6.4)	.22 (5.6)	.67 (17.0)	.15 (3.8)
PN18-6RN	-C -M	MS25036-101 CLASS 1 & 2	#6	.77 (19.6)	.22 (5.6)	.18 (4.6)	.63 (16.0)	.15 (3.8)
PN18-8R	-C -M	MS25036-149 CLASS 1 & 2	#8	.86 (21.8)	.31 (7.9)	.25 (6.4)	.70 (17.8)	.17 (4.3)
PN18-10R	-C -M	MS25036-103 CLASS 1 & 2	#10	.88 (22.4)	.31 (7.9)	.25 (6.4)	.70 (17.8)	.20 (5.1)
PN18-14R	-C -M	MS25036-150 CLASS 1 & 2	1/4"	1.09 (27.7)	.45 (11.4)	.38 (9.7)	.80 (20.3)	.27 (6.9)
PN18-56R	-C -M	MS25036-104 CLASS 1 & 2	5/16"	1.09 (27.7)	.46 (11.7)	.38 (9.7)	.84 (21.8)	.33 (8.4)
PN18-38R	-C -M	MS25036-105 CLASS 1 & 2	3/8"	1.17 (29.7)	.53 (13.5)	.43 (10.9)	.91 (23.1)	.39 (9.9)
PN18-12R	-C	-----	1/2"	1.35 (34.3)	.72 (18.3)	.53 (13.5)	.99 (25.1)	.52 (13.2)

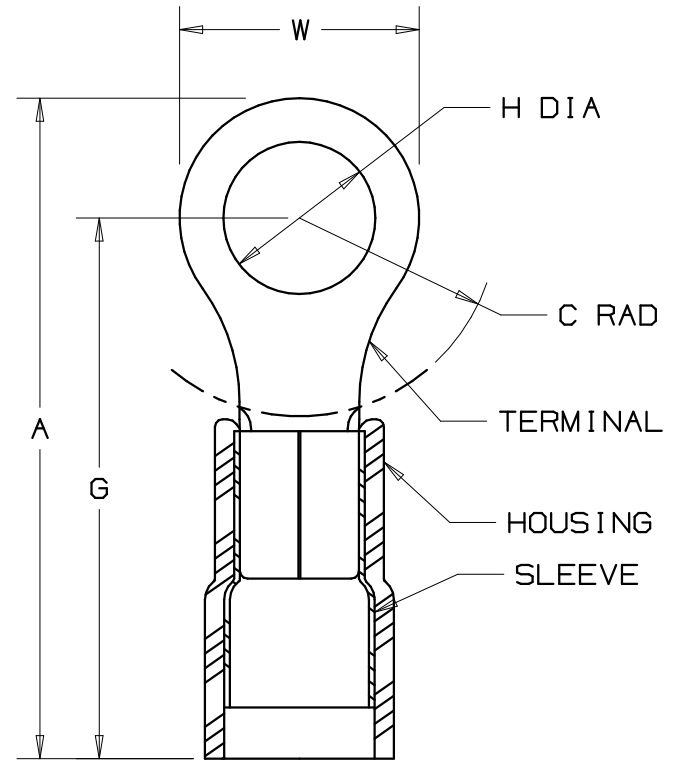

NOTES:

- UL LISTED AND CSA CERTIFIED FOR:
 - 600V. MAX. BLDG. WIRE (1000V. MAX. IN SIGNS, FIXTURES & LUMINARIES)
 - 221°F. (105°C) MAX. TEMP. RATING
 - #22-18 AWG (0.5-1.5mm²) SOLID OR STRANDED COPPER WIRE.
- MATERIAL:
 - STAMPING- .032" (.81) THK. COPPER, TIN PLATED
 - HOUSING- NYLON, RED
 - SLEEVE- BRASS, TIN PLATED
- WIRE STRIP LENGTH- 7/32" +1/32, -0 (5.6, +.8, -0)
- PACKAGE QUANTITY: -C = 100, -M = 1000

5) DIMENSIONS IN PARENTHESIS ARE IN MILLIMETERS

- INSTALLATION TOOLS:
 - UL LISTED AND CSA CERTIFIED: CT-100*, CT-400*, (UL, MIL CLASS 2), CT-500*, CT-550*, CT-1550*, CT-1551*
 - PANDUIT APPROVED: CT-160*, CT-250*
*APPROVED FOR EXPANDED WIRE RANGE #22-16 AWG

Panduit part numbers shown on this drawing meet the material requirements of RoHS (EUROPEAN DIRECTIVES 2002/95/EC) as proposed by the Technical Adaptation Committee



A41543_09

09	12/06	DAW	DAW	RED NYLON WAS INCORRECTLY LISTED AS BLUE IN NOTE 2, LINE B.	TR00188	LCA	TRO
08	8/06	DAW	DAW	ADDED MILITARY PART NO. & CLASS	TR00155	LCA	TRO
07	12/02	SAC	SKB	FOR PN18-12R DIM A WAS 1.34 & DIM G WAS .98 & MADE ALL METRIC DIMS ONE PLACE	10504	LA	TRO
06	11/02	SAC	SKB	ADDED NOTE 3	10489	LA	TRO
05	10/02	SAC	SKB	CHANGED DIM. M TO DIM. G	10480	LA	TRO
REV	DATE	BY	CHK	DESCRIPTION	ECN #	CUST	PM

PANDUIT CORP.

TINLEY PARK, ILLINOIS

3PC. NYLON INSULATED
22-18 BARREL, RING TERMINALS

DRAWN BY BDK CHK'D LA SCALE NONE DRAWING NO. A41543