

Current refinements (click to remove)

[Search Tips](#)
 Region [USA](#) Product Family [Fork Terminal, Nylon Insulated](#) Text Search: 'PN10-10F-D'

Your search criteria matched only one product, shown below.

- Fork design provides for fast and easy installation, without the need to remove fastener
- Metal insulation grip sleeve crimps to wire insulation, providing protection to the crimp joint during high vibration applications
- Internal barrel serrations assure good wire contact and maximum tensile strength
- UL Flammability UL 94V-2/HB, maximum insulation temperature 221°F (105°C)
- UL and CSA rated up to 600 V per UL 486

‡UL and CSA approved tooling/product combinations.

Note: Wire sizes #26 – #22 AWG, are not UL Listed or CSA Certified.

Part Number:	PN10-10F-D
RoHS Compliancy Status:	Compliant
Part Description:	Fork Terminal, nylon insulated, 12 – 10 AWG, #10 stud size.
Product Type:	Terminals
CSA Certified:	Yes
UL Listed:	Yes
Length (In.):	1.04
Width (In.):	.37
Clearance:	.22
Max. Ins.:	.225
Panduit Color Code:	Yellow
Stock:	.04
Stud Size:	#10
Tool:	CT-100A‡, CT-600-A‡, CT-1550‡, CT-1551‡, CT-2500‡
Wire Range:	12 – 10 AWG
Min. Order UOM:	PC
Min. Order Qty.:	500

BOM Qty. (# of Pkgs.)

[Add to My Catalog](#)

 Please [register](#) to utilize the 'Bill of Materials', 'Submit Quotes' and 'My Catalog' features.

THIS COPY IS PROVIDED ON A RESTRICTED BASIS AND IS NOT TO BE USED IN ANY WAY DETRIMENTAL TO THE INTERESTS OF PANDUIT CORP.

PANDUIT PART NUMBER	STUD SIZE	DIMENSIONS in.				
		A $\pm .04$	W $\pm .01$	C $\pm .02$	M $\pm .04$	H $\pm .01$
PN10-6F	#6	1.00 (25.40)	.31 (7.87)	.22 (5.59)	.81 (20.57)	.15 (3.81)
PN10-8F	#8	1.03 (26.16)	.37 (9.40)	.22 (5.59)	.81 (20.57)	.17 (4.32)
PN10-10F	#10	1.04 (26.42)	.37 (9.40)	.22 (5.59)	.81 (20.57)	.20 (5.08)
PN10-14F	1/4"	1.14 (28.96)	.49 (12.45)	.30 (7.62)	.90 (22.86)	.27 (6.86)

NOTES:

- UL LISTED AND CSA CERTIFIED FOR:
 - 600V. MAX. BLDG WIRE (1000 V. MAX IN SIGNS, FIXTURES & LUMINARIES)
 - #14-10 AWG SOLID OR STRANDED COPPER WIRE WITH THE CT-550 INSTALLATION TOOL.
 - #12-10 AWG STRANDED AND #12 AWG SOLID COPPER WIRE WITH THE CT-1550 AND CT-1551 INSTALLATION TOOLS.
 - #12-10 AWG SOLID OR STRANDED COPPER WIRE WITH THE CT-100 INSTALLATION TOOL.
 - 221°F (105°C) MAX TEMP. RATING
- MATERIAL:
 - STAMPING - .04" (1.02) THK COPPER, TIN PLATED
 - HOUSING - NYLON, YELLOW
 - SLEEVE - BRASS, TIN PLATED
- STRIP LENGTH - 9/32 $\begin{smallmatrix} +1/32 \\ -0 \end{smallmatrix}$
- PACKAGE QTY:
 - L=50
 - D=500
- DIMENSIONS IN BRACKETS ARE IN MILLIMETERS

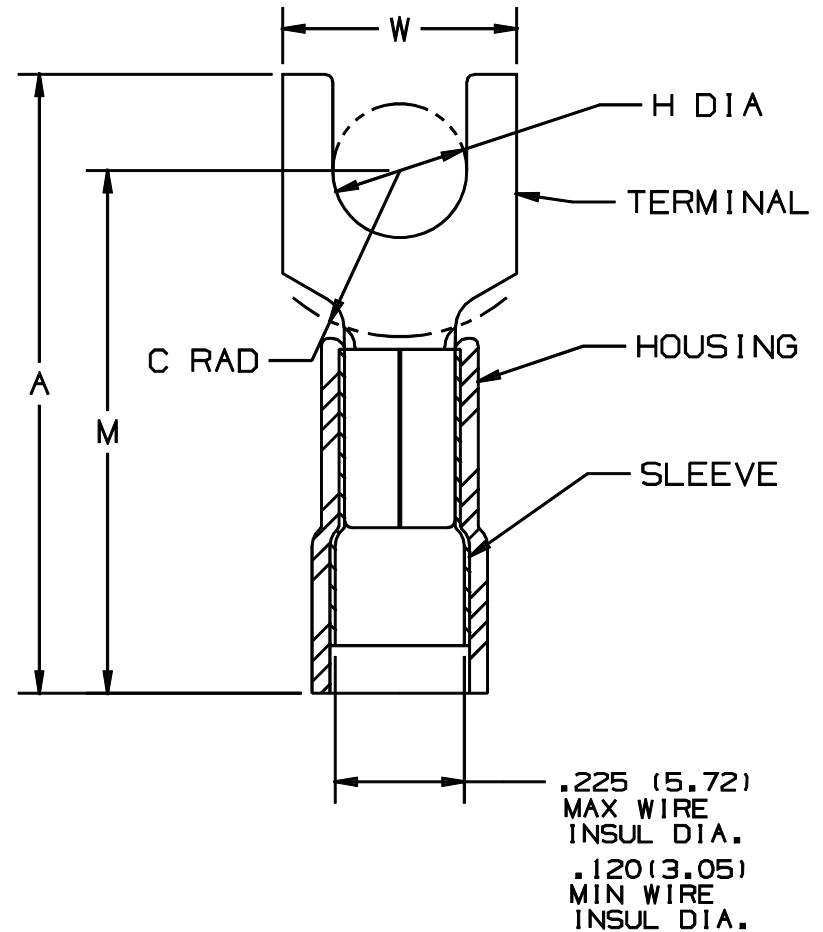

LISTED
587H
E52164



CERTIFIED
LR31212

A41190_04

04	1/01	KMD		CAD FILE SPEC. WAS N41190AA_PCD_03				<p>TINLEY PARK, ILLINOIS</p> <p>3PC. NYLON INSULATED, 12-10 BARREL, FORKS</p>
03	5/99	ED		UPDATED "A" & "M" DIM.S, AND MODIFIED DIMENSIONAL TOLERANCES	07662			
02	12/96	JAMB	RLS	ADDED DIM.. .120(3.05) MIN WIRE INSUL DIA. UPDATED NOTES	05428	LA	DBH	
01	10/94	TH	RLS	UPDATED NOTES AND DIMENSIONS	02583	LA	KRS	
REV	DATE	BY	CHK	DESCRIPTION	ECN #	CUST	PM	DRAWN BY FES CMT'D LA SCALE NONE DRAWING NO. A41190