



PLWP2S-C



- For indoor use
- Cable tie, mount, and fastener in a single part
- Used to attach bundles to another surface such as a flat panel
- Anchor is easily pressed into a pre-formed hole and locks in place
- Wings provide constant tension for a stable, secure and rattle-free installation
- Curved tip is easy to pick up from flat surfaces and allows faster initial threading to speed installation

■ Part Number	PLWP2S-C
■ RoHS Compliancy Status	Compliant
■ Part Description	Wing Push Mount Tie, 7.8", Standard cross section
■ Product Type	Cable Ties
■ Material	Nylon 6.6
■ Color	Natural
■ CSA Certified	Yes
■ UL Listed (File #E56854)	No
■ UL Recognized (File #E56854)	Yes
■ Length (In.)	7.8
■ Length (mm)	198
■ Width (In.)	.190
■ Width (mm)	4.8
■ CE Compliant	Yes
■ Cross Section	Standard
■ Head Height (In.)	.370
■ Head Height (mm)	9.4
■ Locking Style	Locking
■ Material Flammability Rating	UL 94V-2
■ Max. Bundle Diameter (In.)	1.75
■ Max. Bundle Diameter (mm)	45
■ Max. Continuous Use Temperature	185°F (85°C)
■ Max. Panel Thickness (In.)	.105
■ Max. Panel Thickness (mm)	2.7
■ Min. Loop Tensile Strength (Lbs.)	50
■ Min. Loop Tensile Strength (N)	222

■ Nominal Hole Diameter (In.)	.250
■ Nominal Hole Diameter (mm)	6.4
■ Pricing Description	Wing Push Mount Tie, 7.8"L (198mm), Standard, Nylon, Natural
■ Thickness (In.)	.052
■ Thickness (mm)	1.3
■ Tool	GTS, GTSL, GS2B, GTH, GS4H, PTS, PTH, PPTS, STS2, STH2
■ Min. Order UOM	PC
■ Min. Order Qty.	100
■ BOM Qty. (# of Pkgs.)	

THIS COPY IS PROVIDED ON A RESTRICTED BASIS AND IS NOT TO BE USED IN ANY WAY DETRIMENTAL TO THE INTERESTS OF PANDUIT CORP.

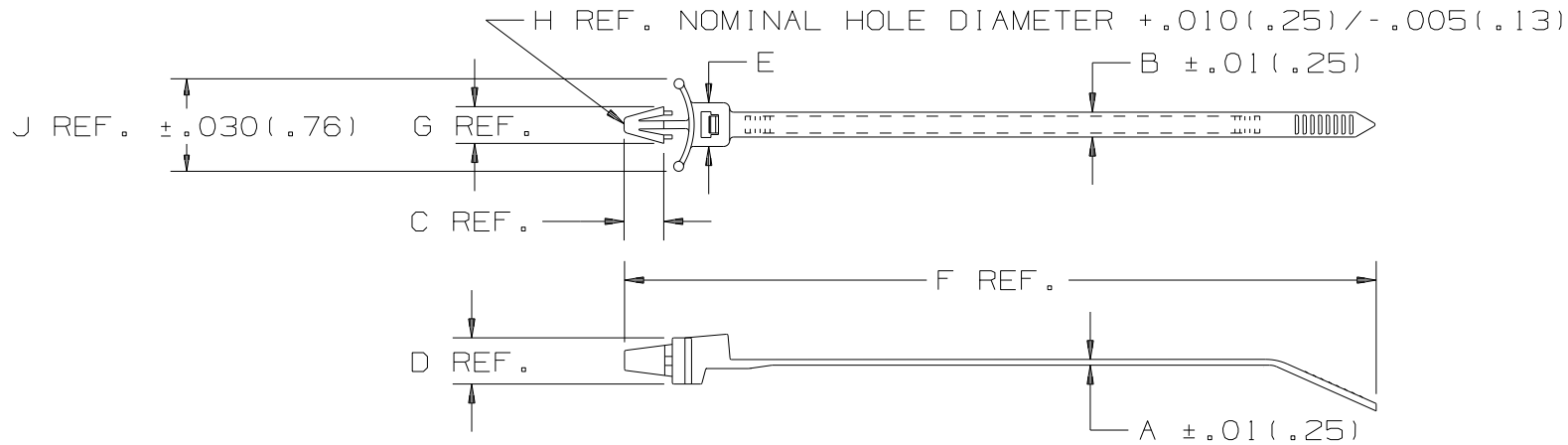

PANDUIT PART NO.	BUNDLE DIAMETER		A	B	C	D	E	F	G	H	J	MAX PANEL THICKNESS in (mm)	MIN. LOOP TENSILE lbs (N)	CROSS SECTION	WEIGHT 100 pcs. lbs (g)
	MIN. in (mm)	MAX. in (mm)													
PLWP1M	.06 (1.5)	.87 (22.1)	.044 (1.1)	.098 (2.5)	.230 (5.8)	.220 (5.6)	.180 (4.6)	4.3 (109)	.240 (6.1)	.187 (4.7)	.53 (13.5)	.093 (2.4)	18 (80)	MINIATURE	.11 (50)
PLWP1.5I	.06 (1.5)	1.25 (31.8)	.045 (1.2)	.135 (3.4)	.230 (5.8)	.280 (7.1)	.240 (6.1)	6.0 (152)	.240 (6.1)	.187 (4.7)	.450 (11.4)	.093 (2.4)	40 (178)	INTERMEDIATE	.17 (77)
PLWP1S	.06 (1.5)	1.00 (25.4)	.052 (1.3)	.190 (4.8)	.300 (7.6)	.370 (9.4)	.316 (8.0)	5.2 (132)	.330 (8.4)	.250 (6.4)	.74 (18.8)	.105 (2.7)	50 (222)	STANDARD	.29 (132)
PLWP1.5S	.06 (1.5)	1.50 (38.1)	.052 (1.3)	.190 (4.8)	.300 (7.6)	.370 (9.4)	.316 (8.0)	6.8 (173)	.330 (8.4)	.250 (6.4)	.74 (18.8)	.105 (2.7)	50 (222)	STANDARD	.34 (154)
PLWP2S	.06 (1.5)	1.75 (44.5)	.052 (1.3)	.190 (4.8)	.300 (7.6)	.370 (9.4)	.316 (8.0)	7.8 (198)	.330 (8.4)	.250 (6.4)	.74 (18.8)	.105 (2.7)	50 (222)	STANDARD	.37 (168)

NOTES:

1. RECOGNIZED UNDER THE COMPONENT PROGRAM OF UNDERWRITERS LABORATORIES INC.
2. SEE CURRENT PRICE SHEET FOR PART NUMBER SUFFIX DESIGNATION FOR PACKAGE SIZE AND PART COLOR.

DIMENSIONS IN PARENTHESES ARE IN METRIC UNITS

PANDUIT CORP. TINLEY PARK, ILLINOIS
 LOCKING WING PUSH MOUNT TIE
 PLWP SERIES

UNLESS OTHERWISE SPECIFIED,
 DIMENSIONAL TOLERANCES ARE:
 (.X) ± .1(2.5) (.XXX) ± .020(.51)
 (.XX) ± .02(.5) ANGLES ± -----

UNLESS OTHERWISE SPECIFIED,
 ALL DIMENSIONS ARE GIVEN
 IN INCHES, THIRD ANGLE PROJECTION.

---	----	---	REMOVED ASTERISKS CONNECTED WITH NOTES	----	---	DRAWN BY C. HARVELL	MAT'L: NYLON 6.6	SCALE NONE
13	6/5/07	JABO	CORRECTED TOLERANCE CONVERSION OF .1	17564	13	DATE 05/26/92		DRAWING NO. SS-17564
REV	DATE	BY	CHK	DESCRIPTION	ECN - R	CUST	SUP	DWG A SIZE
						CHK'D HVP		