

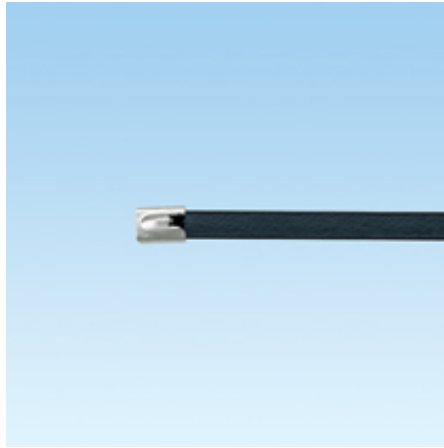

MLTFC2H-LP316



- Self-locking head design speeds installation and locks into place at any length along the tie body
- Polyester coating provides additional edge protection and prevents corrosion between dissimilar metals
- AISI 316 stainless steel for the most corrosive environments
- Available in standard, heavy, extra-heavy and super-heavy cross sections
- UV resistant, low smoke, halogen-free material
- Temperature tolerance -40°F (-40°C) to 302°F (150°C)
- Part thickness is base material less coating.

■ Part Number	MLTFC2H-LP316
■ RoHS Compliancy Status	Compliant
■ Part Description	Polyester coated stainless steel tie, AISI 316, heavy, 7.9" length.
■ Product Type	Stainless Steel Cable Ties
■ Material	Stainless Steel Type 316
■ Color	black
■ Length (In.)	7.9
■ Length (mm)	201
■ Width (In.)	.31
■ Width (mm)	7.9
■ Cross Section	Heavy
■ Max. Bundle Diameter (In.)	2.0
■ Max. Bundle Diameter (mm)	51
■ Min. Bundle Diameter (In.)	.50
■ Min. Bundle Diameter (mm)	12.7
■ Min. Loop Tensile Strength (Lbs.)	250
■ Min. Loop Tensile Strength (N)	1112
■ Pricing Description	MLT Tie, 316 SS, Fully Coated, Heavy, 7.9" (201mm), .010" (.25mm) thk
■ Thickness (In.)	.010
■ Thickness (mm)	.25
■ Tool	GS4MT, HTMT, PPTMT, ST2MT
■ Min. Order UOM	PC
■ Min. Order Qty.	50
■ BOM Qty. (# of Pkgs.)	

THIS COPY IS PROVIDED ON A RESTRICTED BASIS AND IS NOT TO BE USED IN ANY WAY DETRIMENTAL TO THE INTERESTS OF PANDUIT CORP.

PANDUIT PART NO.	PACKAGE QTY.	MAX BUNDLE DIA	"LENGTH" ±.3 [7]
MLTFC2H-LP316	50	2" [51]	7.9"[201]
Ⓐ MLTFC2.7H-LP316	50	2.7" [69]	10.15"[258]
MLTFC4H-LP316	50	4" [102]	14.3"[362]
MLTFC6H-LP316	50	6" [152]	20.5"[521]
MLTFC8H-LP316	50	8" [203]	26.8"[679]

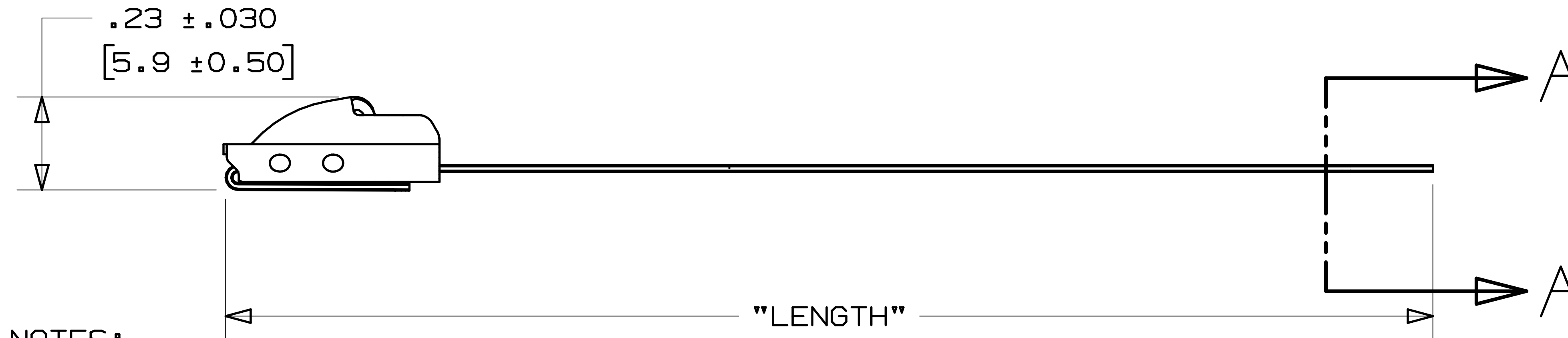
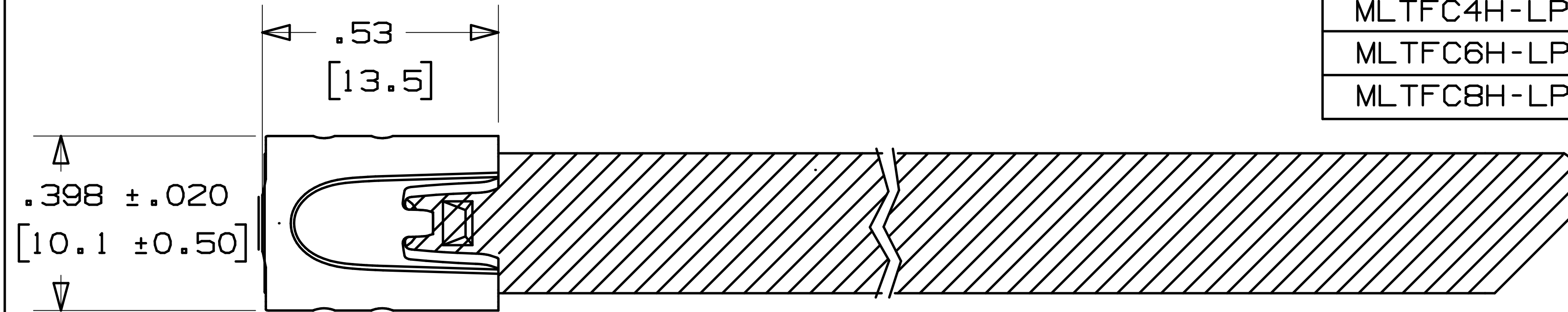

NOTES:

- 1.) APPLICATION TOOLS - GS4MT, PPTMT, ST2MT, HTMT OR ST3MT
- 2.) MINIMUM LOOP TENSILE STRENGTH - 250 LBS. (1112 NEWTONS) WHEN TESTED ON A 1.5" MANDREL.
- 3.) [] DENOTES DIMENSION IN MILLIMETERS
- 4.) TOLERANCES:
 .XXX = ±.010 [.25]
 .XX = ±.02 [.5]
 .X = ±.03 [.8]
 ANGLES = ±2°
- 5.) MATERIAL: 316 STAINLESS STEEL
- 6.) COATING - POLYESTER
 COATING THICKNESS: .002 MIN./ .005 MAX. PER SIDE

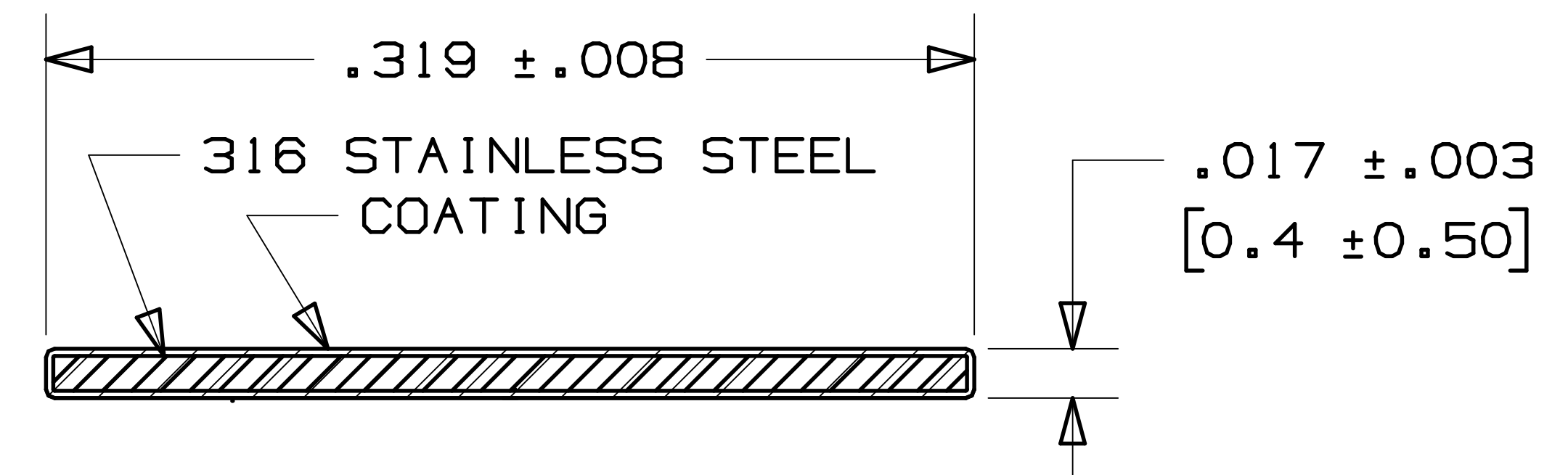

SECTION A - A
SCALE: 10x

S41193_02

REV	DATE	BY	CHK	DESCRIPTION	ECN #	PM	CUST	DRAWN BY	CHK'D	SCALE	DRAWING NO.
02	11/05	JMMR	EJD	Ⓐ ADDED MLTFC2.7H-LP316 TO TABLE	SS00112	---	---	PANDUIT CORP. TINLEY PARK, ILLINOIS METAL LOCKING TIE - COATED HEAVY SERIES 316 STAINLESS STEEL (CUSTOMER DRAWING)			
01	3/05	JAMB	PAB	DRAWING REVISED TO REFLECT CURRENT COATED HEAVY SERIES PRODUCT	12501	CCH	JJB				
00	11/04	JAMB	PAB	RELEASED	12169	CCH	JJB				
								DRAWN BY	CHK'D	SCALE	DRAWING NO.
								JAMB	PAB	2x	S41193