

Current refinements (click to remove)

[Search Tips](#) 
 [Region](#) **USA** [Product Family](#) **Flex Conductor, One-Hole, Standard Barrel with Window Lug** [Text Search:](#) 'LCAX1-14-X'

For Use with Flexible, Extra-Flexible, and Code Stranded Copper Conductors

- Can be used with code conductor and flex conductor class: G, H, I, K, M and Diesel Locomotive
- Generously beveled wire entry prevents bent back strands when inserting conductor into barrel
- Color-coded barrels marked with *PANDUIT* and specified competitor die index numbers for proper crimp die selection
- Inspection window to visually assure full conductor insertion
- Tin-plated to inhibit corrosion
- UL Listed and CSA Certified to 35 KV** and temperature rated to 90°C when crimped with *PANDUIT* and specified competitor crimping tools and dies
- American Bureau of Shipping Approved

Related Products

- [Contour Crimp™ Control...](#)
- [Die Type, Battery Powered Hydraulic...](#)
- [Die Type, Battery Powered Hydraulic...](#)
- [CD-2001 Crimping Dies](#)
- [Die Type, Manual Hydraulic, 14 Ton,...](#)
- [Die Type, Remote Hydraulic, 14 Ton,...](#)
- [More...](#)

Part Number:	LCAX1-14-X
RoHS Compliancy Status:	Compliant
Part Description:	Flex Lug, #1 AWG, 1/4" Stud Hole
Length (In.):	1.67
Length (mm):	42.4
Class G,H, I, K, M:	#1 AWG
Diesel Locomotive:	#1 AWG
Stud Hole Size (In.):	1/4
Tongue Width (In.):	.76
Barrel Length (In.):	.66
Angle:	Straight
Figure No.:	1
Panduit Color Code:	Green
Panduit Die Index No.:	P37
Tongue Thickness:	.12
Tongue Type:	Standard
Tongue Width (mm):	19.3
Wire Strip Length (In.):	3/4
Min. Order UOM:	PC
Min. Order Qty.:	1
Burndy Die Index No.:	11
T&B Die Index No.:	37
BOM Qty. (# of Pkgs.)	

[Add to My Catalog](#)

 Please [register](#) to utilize the 'Bill of Materials', 'Submit Quotes' and 'My Catalog' features.

THIS COPY IS PROVIDED ON A RESTRICTED BASIS AND IS NOT TO BE USED IN ANY WAY DETRIMENTAL TO THE INTERESTS OF PANDUIT CORP.

Material	High Conductivity Seamless Copper Tube
Plating	Electro-Tin
Wire Size	1 STR/FLEX
Wire Type	Stranded Copper: Class B & C, Compact, Class G, H, I, K, M, Locomotive
Wire Strip Length	3/4 in.
Stud Size	1/4 in.
UL Listed Wire Connector	Yes, for applications up to 35kv. Consult cable manufacturer for voltage stress relief instructions with applications greater than 2000 volts.
UL Temperature Rating	90° C
C.S.A Certified Wire Connector	Yes
Panduit Color Code on Barrel	GREEN
Panduit Die Index No. on Barrel	P37
Alternate Industry Die Index No. () on Barrel	(11)

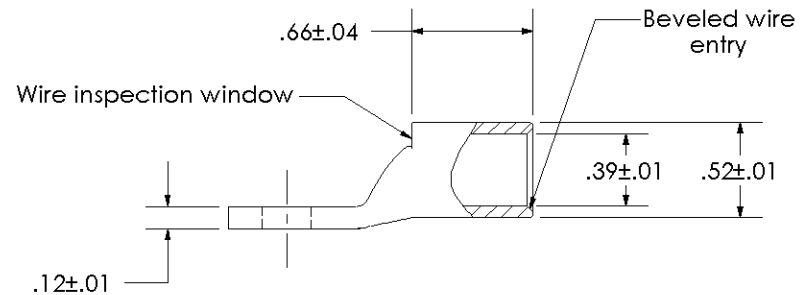
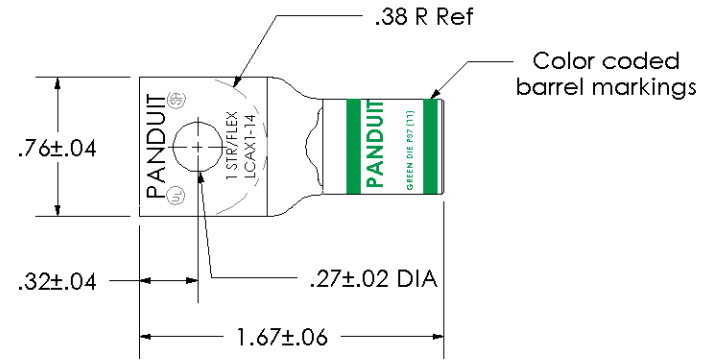

CERTIFIED



LISTED Wire Connector

PANDUIT CORP. TINLEY PARK, ILLINOIS

LCAX1-14-X
Copper Lug - One-Hole, Standard Flex Barrel

00 6/03 CJW SAC

RELEASED

10850

REV DATE BY CHK

DESCRIPTION

ECN

SCALE
N/A

DRAWING NO / CAD FILE

LCAX1-14-CUST