

Current refinements (click  to remove)

[Search Tips](#) 
 [Region](#)  [USA](#)  [Product Family](#)  [One-Hole, Single Barrel Lug](#)  [Text Search](#): 'LAMA250-56-QY'

**Your search criteria matched only one product, shown below.**
[Joint Compounds](#)

For Use with Stranded Aluminum or Copper Code Conductors

- Made from high strength, extruded aluminum alloy to provide premium electrical and mechanical performance
- Tin-plated to inhibit corrosion
- Compact design saves space
- Wide wire range-taking capability minimizes inventory requirements
- Inspection window to visually assure full conductor insertion
- Plated steel or aluminum set screw provides high strength, durable electrical contact between conductor and connector
- UL Listed and CSA Certified for use up to 600 V and UL temperature rated 90°C

Part Number:	LAMA250-56-QY
RoHS Compliancy Status:	Compliant
Note:	LAMA250-56-QY replaces LAMA250-56-Q
Part Description:	Aluminum, single barrel, one-hole tongue connector, type LAMA.
Product Type:	Mechanical Connectors - Lugs
CSA Certified:	Yes
UL Listed:	Yes
Height (In.):	1.06
Height (mm):	26.9
Length (In.):	2.00
Length (mm):	50.8
Stud Hole Size (In.):	5/16
Tongue Width (In.):	.90
Aluminum or Copper Conductor Size Range:	#6 AWG – 250 kcmil
Hex Key Size (In.):	3/8
Tightening Torque (In-Lbs):	375*
Tongue Length:	1.00
Tongue Thickness:	.22
Tongue Width (mm):	22.9
Min. Order UOM:	PC
Min. Order Qty.:	1

BOM Qty. (# of Pkgs.)

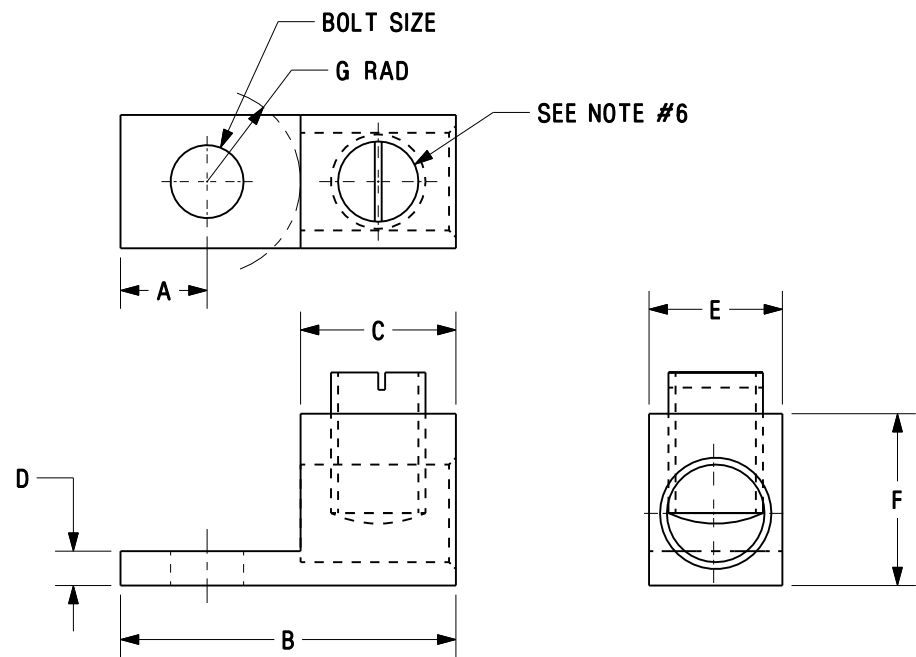

FIGURE #1

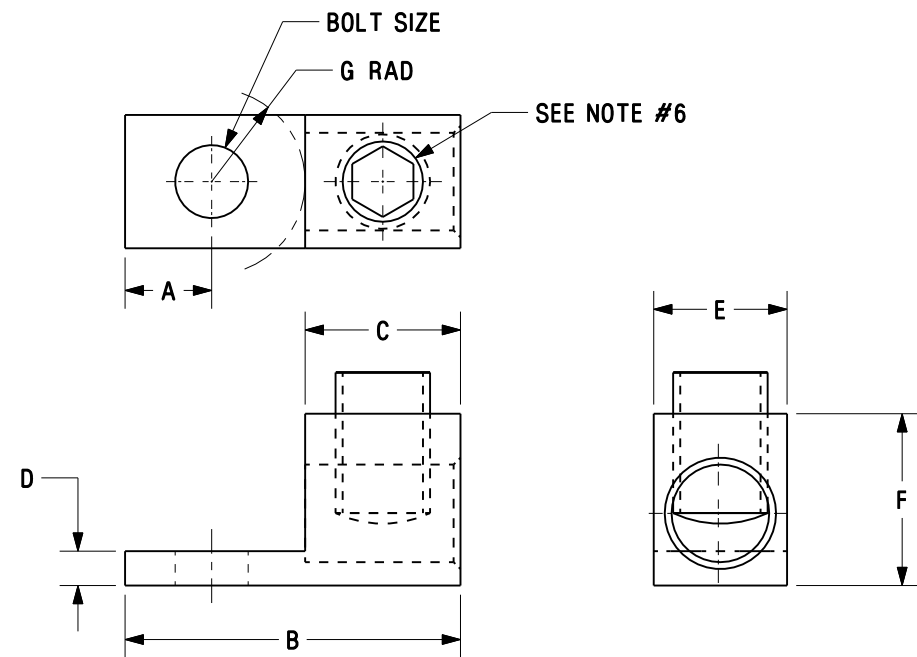

FIGURE #2

NOTES:

1. U.L. LISTED PER 486B UP TO 600V. TEMPERATURE RATED 90° C
2. C.S.A. CERTIFIED UP TO 600V.
3. ALUMINUM PARTS AND SCREWS ARE TIN PLATED. STEEL SCREWS ARE ZINC PLATED
4. TO BE USED WITH COPPER OR ALUMINUM STRANDED WIRE.
5. MADE IN U.S.A.
6. \*S - DESIGNATES SLOTTED SCREW.
7. PKG. QTY.: -Q=25
8. THIS PART IS RoHS COMPLIANT.

ALUMINUM MECHANICAL CONNECTORS TYPE: LAMA

\*PART WEIGHT INCLUDES SCREW AND BODY

CAT. NO.	FIGURE	WIRE RANGE COPPER/ALUMINUM	WIRE STRIP LENGTH IN. (mm)	BOLT SIZE IN.	DIM A IN.	DIM B IN.	DIM C IN.	DIM D IN.	DIM E IN.	DIM F IN.	DIM G IN.	INSTALLATION TORQUE in-lbs (N-m)	HEX KEY	SCREW MAT'L	PART WEIGHT lb [kg]
LAMA6-14-QY	1	6-14AWG	.38 (9.7)	1/4	.25	1.06	.38	.09	.38	.50	.43	45 (5.1)	*S	STEEL	.016 lb (.007 kg)
LAMA2-14-QY	1	2-14AWG	.47 (11.9)	1/4	.32	1.16	.47	.09	.50	.56	.37	12-14AWG-15 (1.7) 6-10AWG-40 (4.5) 2-4AWG-50 (5.6)	*S	STEEL OR AL	.020 lb (.009 kg)
LAMA1/0-14-QY	1	1/0-14AWG	.63 (16.0)	1/4	.44	1.47	.63	.19	.62	.81	.40	10-14AWG-35 (3.9) 8AWG-40 (4.5) 4-6AWG-45 (5.1) 1/0-3AWG-50 (5.6)	*S	AL	.036 lb (.016 kg)
LAMA2/0-14-QY	1	2/0-14AWG	.63 (16.0)	1/4	.44	1.47	.63	.19	.62	.81	.40	10-14AWG-35 (3.9) 8AWG-40 (4.5) 4-6AWG-45 (5.1) 2/0-3AWG-50 (5.6)	*S	AL	.036 lb (.016 kg)
LAMA250-56-QY	2	250MCM-6AWG	1.00 (25.4)	5/16	.44	2.00	1.00	.22	.90	1.06	.56	2-6AWG-275 (31.1) 250MCM-1AWG-375 (42.4)	3/8	AL	.092 lb (.042 kg)

CAD FILENAME/LAYERS		C41566_06	
PANDUIT		CORP TINLEY PARK, ILLINOIS	
LAMA SERIES 6AWG THRU 250kcmil ALUMINUM MECHANICAL LUGS			
UNLESS OTHERWISE SPECIFIED, DIMENSIONAL TOLERANCES ARE: (.X) ± .005 (.XX) ± .005		UNLESS OTHERWISE SPECIFIED, ALL DIMENSIONS ARE GIVEN IN INCHES, THIRD ANGLE PROJECTION	
DRAWN BY JHNU	MAT'L: SEE NOTES	SCALE NONE	
DATE 2/06	CHK'D	DRAWING NO. C41566	DWG SIZE B

REV	DATE	BY	CHK	DESCRIPTION	ECN #	CUST	GMBH
06	1/07	JHNU	JHNU	ADDED PART WEIGHT COLUMN TO TABLE	PC00639		
--	-----	---	---	ADDED VIEWS OF PART WITH SLOTTED SCREWS ADDED NOTE TO REFERENCE NOTE 6. ADDED FIGURE COLUMN TO TABLE.	-----		
05	1/07	JHNU	JHNU		PC00629		
04	11/06	JHNU	JHNU	REVISED NOTES 1 AND 2: ADDED 600V AND TEMPERATURE RATED 90° C.	PC00611		
03	7/06	JHNU	LEM	REVISED PART NUMBER: LAMA2/0-14-QY WAS LAMA2/0-14-Q	PC00487		
02	6/06	JHNU	LEM	REVISED PART NUMBERS: LAMA6-14-QY WAS LAM6-14-Q LAMA2-14-QY WAS LAMA2-14-Q	PC00485		
01	3/06	JHNU	LEM	REVISED ROHS NOTE	PC00334		
00	2/06	JHNU	LEM	DRAWING RELEASED - ROHS COMPLIANT	PC00299		