

Current refinements (click  to remove)

[Search Tips](#) 
 [Region](#) **USA** [Product Family](#) **Female Disconnect, Nylon Fully Insulated – Funnel Entry** [Text Search:](#) 'DNF10-250FIB-L'

Your search criteria matched only one product, shown below.
[DiscoGrip™ Male Discon...](#)

- Disconnect can be inserted and removed from the male tab without the use of tools for lower installed cost
- Premium nylon insulation retains its shape when crimped and provides a tight grip around the wire insulation for maximum strain relief
- Fully insulated design provides protection from electrical shorts
- Internal wire stop assures proper length of insertion into terminal barrel, providing a higher quality connection
- Disconnects available in common industry tab sizes
- UL and CSA rated up to 600 V per UL 310

Part Number:	DNF10-250FIB-L
RoHS Compliancy Status:	Compliant
Part Description:	Female disconnect, nylon fully insulated, funnel entry, 12 – 10 AWG, .250 X .032 tab size, butted seam.
Product Type:	Disconnects
CSA Certified:	Yes
UL Listed:	Yes
Height (In.):	.23
Length (In.):	.96
Width (In.):	.35
Max. Ins.:	.220
Panduit Color Code:	Yellow
Tab Size (In.):	.250 x .032
Tool:	CT-1525‡, CT-2500‡
Wire Range:	12 – 10 AWG
Min. Order UOM:	PC
Min. Order Qty.:	50
BOM Qty. (# of Pkgs.)	

[Add to My Catalog](#)

 Please [register](#) to utilize the 'Bill of Materials', 'Submit Quotes' and 'My Catalog' features.

THIS COPY IS PROVIDED ON A RESTRICTED BASIS AND IS NOT TO BE USED IN ANY WAY DETRIMENTAL TO THE INTERESTS OF PANDUIT CORP.

NOTES:

- UL LISTED AND CSA CERTIFIED FOR:
 - 600V MAX VOLTAGE RATING
 - 221°F (105°C) MAX TEMP RATING (CSA).
 - 257°F (125°C) MAX. TEMP. RATING (UL).
 - STRANDED COPPER WIRE ONLY.
 - 6-12 LBS. INITIAL INSERTION/WITHDRAWL FORCE.
- MATERIAL:
 - STAMPING-CDA 260 BRASS, TIN PLATED
 - HOUSING-TYPE 66 NYLON
- DIMENSIONS IN BRACKETS ARE IN mm OR mm²
- COLORS ARE TRANSLUCENT
- PACKAGING:
 - STD -C=100, -L=50
 - BULK -M=1000, -D=500

PART NUMBER	PK	TAB SIZE	WIRE RANGE AWG (mm ²)	COLOR (note 4)	MAX. INSUL.	DIMENSIONS in.			STRIP LENGTH +1/32 (.08) - 0	TOOL CHART
						A ±.03 (.8)	B ±.01 (.3)	C ±.02 (.5)		
DNF18-250F1B	-C -M	.250 X .032	22-18 (0.5-1.5)	RED	.136 (3.45)	.84 (21.3)	.35 (8.9)	.22 (5.6)	9/32 (7.1)	CT-520 CT-1525
DNF18-205F1B	-C -M	.205/.187 X .032	22-18 (0.5-1.5)	RED	.136 (3.45)	.78 (19.8)	.31 (7.9)	.22 (5.6)		
DNF18-206F1B	-C -M	.205/.187 X .020	22-18 (0.5-1.5)	RED	.136 (3.45)	.78 (19.8)	.31 (7.9)	.22 (5.6)		
DNF18-187F1B	-C -M	.187 X .032	22-18 (0.5-1.5)	RED	.136 (3.45)	.78 (19.8)	.29 (7.4)	.16 (4.1)		
DNF18-188F1B	-C -M	.187 X .020	22-18 (0.5-1.5)	RED	.136 (3.45)	.78 (19.8)	.29 (7.4)	.16 (4.1)		
DNF14-250F1B	-C -M	.250 X .032	16-14 (1.5-2.5)	BLUE	.160 (4.06)	.84 (21.3)	.35 (8.9)	.22 (5.6)		
DNF14-205F1B	-C -M	.205/.187 X .032	16-14 (1.5-2.5)	BLUE	.160 (4.06)	.78 (19.8)	.31 (7.9)	.22 (5.6)		
DNF14-206F1B	-C -M	.205/.187 X .020	16-14 (1.5-2.5)	BLUE	.160 (4.06)	.78 (19.8)	.31 (7.9)	.22 (5.6)		
DNF14-187F1B	-C -M	.187 X .032	16-14 (1.5-2.5)	BLUE	.160 (4.06)	.78 (19.8)	.29 (7.4)	.18 (4.6)		
DNF14-188F1B	-C -M	.187 X .020	16-14 (1.5-2.5)	BLUE	.160 (4.06)	.78 (19.8)	.29 (7.4)	.18 (4.6)		
DNF10-250F1B	-L -D	.250 X .032	12-10 (4.0-6.0)	YELLOW	.220 (5.59)	.96 (24.4)	.35 (8.9)	.23 (5.8)	3/8 (9.5)	CT-1525

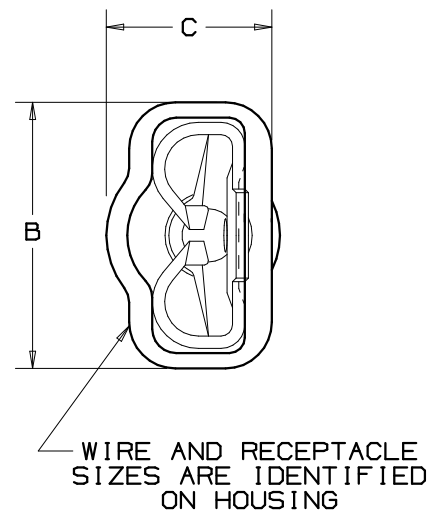
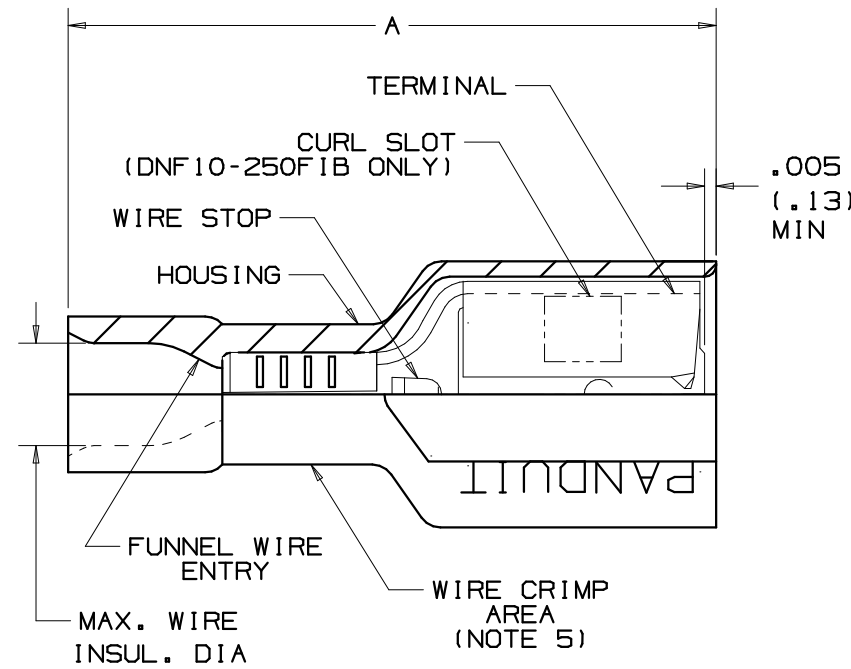

13	9/06	DAW	DAW	REVISED ILLUSTRATION TO SHOW DNF10-250F1B CURL SLOT	TR00160	TRO	LCA
12	8/05	RT	RT	ADDED WIRE STRIP LENGTH	TR00011	TRO	LCA
11	7/03	KLFU		ADDED INTERNAL SERRATIONS; NOTE 5 WAS NOTE 6			
10	5/01	KMD	SKB	REMOVED DNF10-250FI FROM TABLE.	09411	TRO	JAC
09	1/99	WB	SKB	ADDED 18/14 187 & 188 FIBS	07445	TRO	JCJ
08	6/98	TM	JW	ADDED CT-1525, AND DNF10-250F1B	06881	DBH	LA
07	4/95	MS	RS	REVISED SLOT NOTE	03167	KS	LA
06	4/95	MS	RS	ADDED NOTE TO SLOT	03133	KS	LA
05	10/94	MS	RS	UPDATED NOTES AND DIMENSIONS	02507	TFK	LA
REV	DATE	BY	CHK	DESCRIPTION	ECN #	PM	CUST

A41196_13

PANDUIT

CORP TINLEY PARK, ILLINOIS

FULLY INSULATED FEMALE DISCONNECTS
.250 X .032, .205/.187 X .187/.188 X .032/.020

UNLESS OTHERWISE SPECIFIED, DIMENSIONAL TOLERANCES ARE: (.X) ± (.XX) ±		UNLESS OTHERWISE SPECIFIED, ALL DIMENSIONS ARE GIVEN IN INCHES, THIRD ANGLE PROJECTION	
SCALE	NONE		
DRAWING NO.	A41196	DWG SIZE	B

UNLESS OTHERWISE SPECIFIED, DIMENSIONAL TOLERANCES ARE:
(.X) ±
(.XX) ±
ANGLES ±

DRAWN BY: WJB MAT'L:

DATE: 1/6/99

CHK'D: