

4
3
2
1

CONNECTOR PRO SERIES 205 MALE						
Contacts number nn	Length without Latches in mm		Contacts reference mark number			
	A	C	D	E	F	G
04	2	7.4	1	2	3	4
06	4	9.4	1	3	4	6
08	6	11.4	1	4	5	8
10	8	13.4	1	5	6	10
12	10	15.4	1	6	7	12
14	12	17.4	1	7	8	14
16	14	19.4	1	8	9	16
18	16	21.4	1	9	10	18
20	18	23.4	1	10	11	20
22	20	25.4	1	11	12	22
24	22	27.4	1	12	13	24
26	24	29.4	1	13	14	26
28	26	31.4	1	14	15	28
30	28	33.4	1	15	16	30
32	30	35.4	1	16	17	32
34	32	37.4	1	17	18	34
36	34	39.4	1	18	19	36
38	36	41.4	1	19	20	38
40	38	43.4	1	20	21	40
42	40	45.4	1	21	22	42
44	42	47.4	1	22	23	44
46	44	49.4	1	23	24	46
48	46	51.4	1	24	25	48
50	48	53.4	1	25	26	50

Latch separation tool P/N C14790

LF contacts insertion & withdrawal tool P/N C12935

Recommended hand crimp tool P/N MH800

Recommended positioner K1692 P/N C12929

AWG24 crimp tool setting Position 7

AWG26 & AWG28 crimp tool setting Position 6

Ce plan est la propriété exclusive de la société NICOMATIC. Il ne peut être reproduit sans son autorisation. Loi du 11.03.1902.

This document and drawings, sketches, and schematic drawings are the property of the NICOMATIC company. and no parts thereof may be reproduced and used without the written consent of the owner. Law dated 11.03.1902

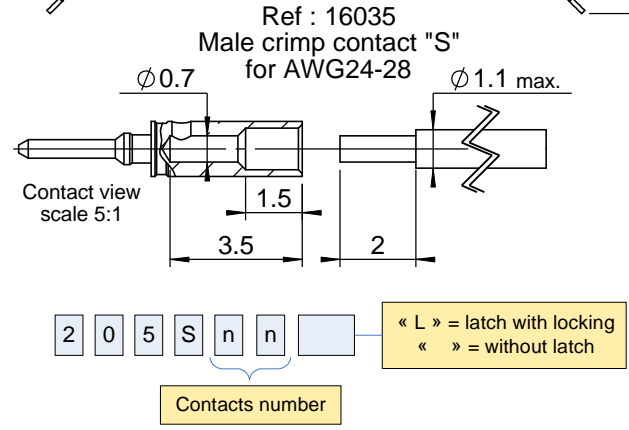
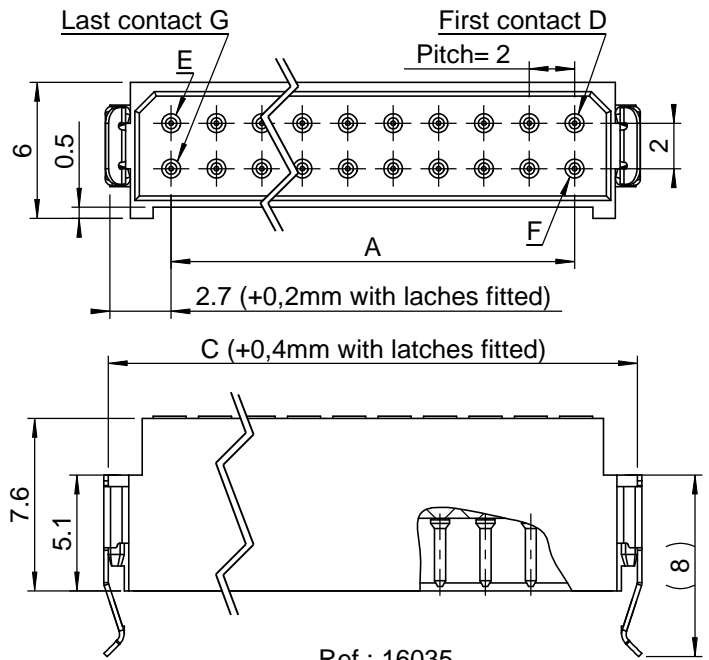

TECHNICAL FEATURES

MATERIALS

INSULATOR : Glass filled thermoplastic UL 94-V0

CRIMPING SIGNAL CONTACTS :
Male : Brass / 0.3µ gold plated

FIXING HARDWARE :

- Latch : Beryllium copper / Ni 2µ nickel plated

ELECTRICAL

- All contacts 3 A max. @ 25°C
2.2 A max. @ 85°C
- Working / Rated voltage (sea level) 300V AC/DC
- Proof / Withstanding voltage 400V AC/DC
- Contact resistance (initial) max. 20 mΩ
- Contact resistance (after conditioning) max. 25 mΩ
- Insulation resistance (initial) 1000 MΩ min

MECHANICAL

- Mechanical operations 500 cycles.
- Contact insertion and withdrawal force 2N max. / 0.2 N min.
- Contact retention in insulator 10N min.

ENVIRONMENTAL

- Temperature range From -55°C to +125°C
Peak Reflow Compatible 260°C Yes
- RoHS

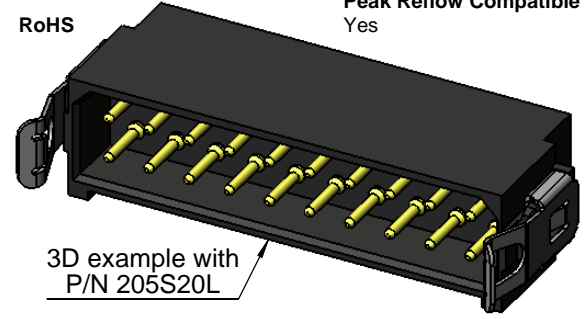

173, rue des fougères
Z.I. Les Bracots
F-74890 Bons-en-Chablais

Tel. : +33 (0)4.50.36.13.85
Fax : +33 (0)4.50.36.11.33
Web : www.nicomatic.com

Echelle/Scale
3:1

a	16/05/08	H.T.		D.Z.
Ind	Date	Drawn	Checked	Approved
Désignation : Connector CMM200 Pro series Male crimp AWG24-28				

205Snn(L)_cl	Réf. catalogue / Catalogue Reference	205Snn(L)	Tolérance générale / General tolerance ±0.2	Page 1/1	A4
--------------	---	------------------	---	----------	----

D A