

CUT A-A

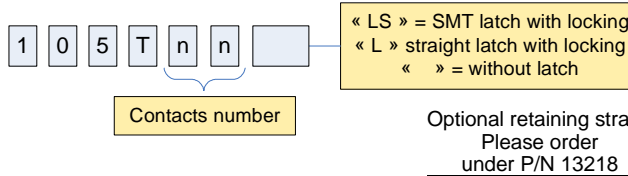
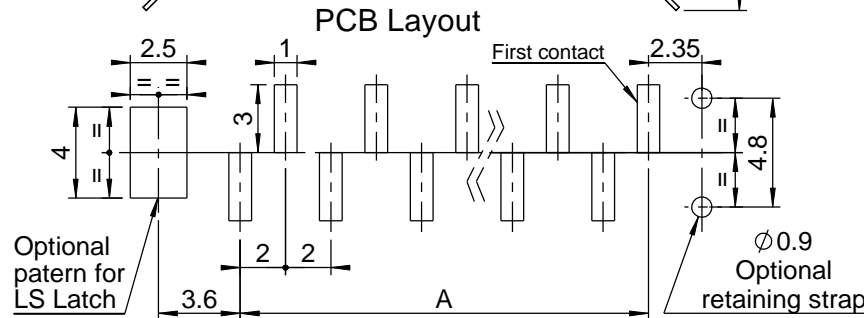
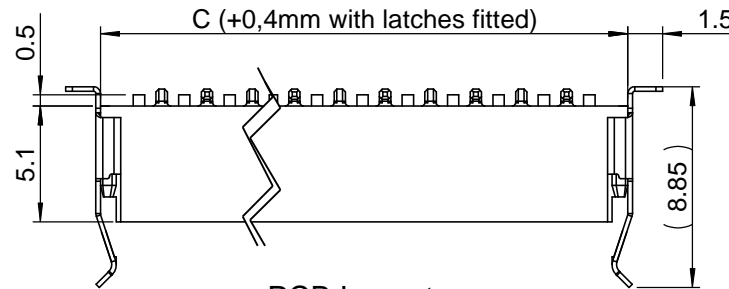
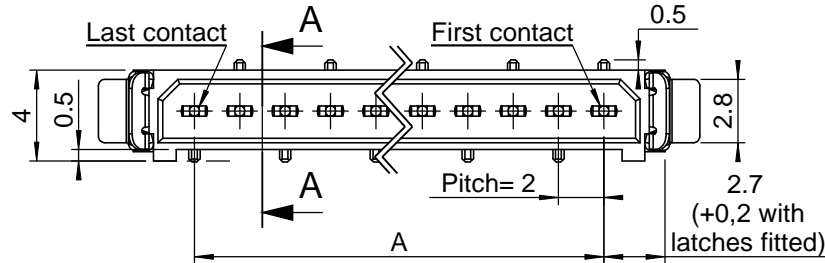
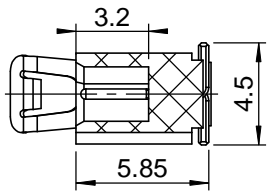

TECHNICAL FEATURES

MATERIALS

INSULATOR : Glass filled thermoplastic UL 94-V0

SIGNAL CONTACTS for PCB:

Male : Brass / 0.75µ gold on contact area
3µ to 5µ 100% tin on tails over Ni under plate

FIXING HARDWARE :

- Latch : Beryllium copper / 2µ nickel plated

ELECTRICAL

- All contacts: 3 A max. @ 25°C, 2.2 A max. @ 85°C
- Working / Rated voltage (sea level): 300V AC/DC
- Proof / Withstanding voltage: 400V AC/DC
- Contact resistance (initial): max. 20 mΩ
- Contact resistance (after conditioning): max. 25 mΩ
- Insulation resistance (initial): 1000 MΩ min

MECHANICAL

- Mechanical operations: 500 cycles.
- Contact insertion and withdrawal force: 2N max. / 0.2 N min.
- Contact retention in insulator: 10N min.

ENVIRONMENTAL

- Temperature range: From -55°C to +125°C
- RoHS: Peak Reflow Compatible 260°C Yes

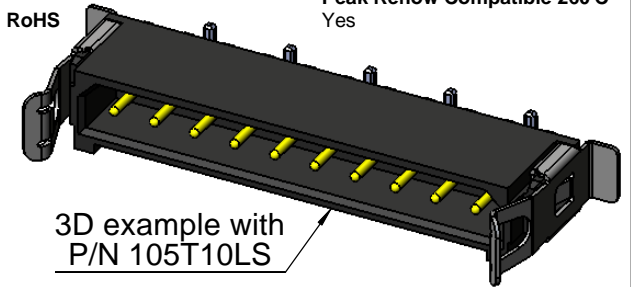

CONNECTOR PRO SERIES 105 MALE		
Contacts number nn	Length without latches in mm	
	A	C
02	2	7.4
03	4	9.4
04	6	11.4
05	8	13.4
06	10	15.4
07	12	17.4
08	14	19.4
09	16	21.4
10	18	23.4
11	20	25.4
12	22	27.4
13	24	29.4
14	26	31.4
15	28	33.4
16	30	35.4
17	32	37.4
18	34	39.4
19	36	41.4
20	38	43.4
21	40	45.4
22	42	47.4
23	44	49.4
24	46	51.4
25	48	53.4

Latch separation tool	P/N C14790
Strain relief straps	P/N 13218

Ce plan est la propriété exclusive de la société NICOMATIC. Il ne peut être reproduit sans son autorisation. Loi du 11.03.1902.

This document and drawings, sketches, and schematic drawings are the property of the NICOMATIC company, and no parts thereof may be reproduced and used without the written consent of the owner. Law dated 11.03.1902



173, rue des fougères
Z.I. Les Bracots
F-74890 Bons-en-Chablais
Tel. : +33 (0)4.50.36.13.85
Fax : +33 (0)4.50.36.11.33
Web : www.nicomatic.com

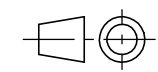

Echelle/Scale
3:1

a	23/05/08	H.T.		D.Z.
Ind	Date	Drawn	Checked	Approved

Désignation : Connector CMM100 Pro series Male straight SMT

105Tnn(LS)	Réf. catalogue / Catalogue Reference	105Tnn(LS)	Tolérance générale / General tolerance	±0.2	Page 1/1	A4
------------	---	-------------------	--	------	----------	----