

The Science of Reliable Control

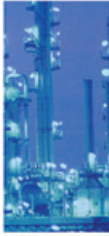

Timing Devices

Temperature Indicators & Controls

Dust Collector Controls

Custom Machine Controls

Solid State Relays

Liquid Level Controls

Voltage Monitors



CUSTOM CONTROLS CAPABILITY

AMETEK NCC:

- *Designs, engineers, and manufactures high-quality electronic controls for the value-driven and quality-conscious OEM customer.*
- *Provides solutions for the growing trend of corporate downsizing. Its fully turnkey, engineering and manufacturing solutions address the challenge and respond to rapid technological changes.*
- *Leads design and manufacture of custom electronic controls and assemblies through day-to-day interaction in design development in partnership with OEM customers.*
- *Increases customer satisfaction, confidence and loyalty through a multi-level, interactive organization that creates a high degree of mutual dependence.*
- *Emphasizes micro-controller hardware and software design in conjunction with analog and digital circuitry.*

Let AMETEK NCC be your partner in full-service design and manufacturing of custom electronic controls and assemblies.

ABOUT NATIONAL CONTROLS

National Controls Corporation (NCC) is a unit of AMETEK, Inc., a leading global manufacturer of electronic instruments and electric motors with annualized sales of more than \$1.4 billion. AMETEK has over 8,500 employees at more than 70 plants and facilities in the United States and 18 other countries.

Headquartered in suburban Philadelphia, AMETEK consists of two operating groups:

Electronic Instruments—*a leading manufacturer of advanced instruments for the aerospace, process and industrial markets.*

Electromechanical—*the world's leading producer of high-speed, air-moving electric motors for floor-care, aerospace, military, mass transit, business equipment and medical devices.*

AMETEK's Corporate Growth Plan is based on Four Growth Strategies: Strategic Acquisitions & Alliances, Global & Market Expansion, New Products and Operational Excellence.

NCC serves as an excellent example of AMETEK's Strategic Acquisitions & Alliances growth strategy. Acquired in January 1999, NCC enhanced AMETEK's position in electronic controls for industrial applications.

NCC is part of AMETEK's Dixon Division, which produces electronic controls for heavy-vehicle, foodservice, and industrial markets. AMETEK Dixon is the number-one U.S. supplier of electronic dashboard instruments for heavy trucks and other vehicles.

In addition to standard product industrial controls, AMETEK NCC provides its customers with innovative and proven product and service solutions. NCC partners with its customers to better meet their design needs, and satisfy their requirements for product quality, reliability, and cost competitiveness.





At National Controls, effective communication is the key to our success. Whether standard product or custom, NCC uses a team approach that involves our customer, sales, engineering, manufacturing, and quality assurance. We built our business by solving problems. The lead team member, our customer, defines the problem. NCC engineering, sales, and manufacturing will solve the problem.

Effective Electronic Controls and Effective Customer Support

Sales will understand and represent our customer's needs to ensure that they are communicated accurately, and that the price point and design continues to meet or exceed the customer's expectation.

Engineering will translate the customer's control requirements into a design that is reliable, manufacturable, and meets the customer's needs while complying with industry and safety agency standards. Our experience in electronic controls provides us with the ability to offer product enhancements to improve our customer's end product.

Manufacturing will build your product as efficiently as possible, maintaining cost structure, utilizing state-of-the-art manufacturing and process controls to ensure the highest quality product.

Effective communication between our customer and the NCC team ensures customer satisfaction.





Engineering Support

More than 20 engineers, circuit designers, software developers, and support staff quickly respond to your specific application with a standard or custom solution. National Controls provides in-house capability with:

- *Computer-aided design*
- *Programming for microprocessor-based designs*
- *Fully equipped model shop and prototyping capabilities*
- *On-site, certified testing facilities for UL and CUL. Equipment and facilities available for FCC and other agency testing*

Manufacturing Support

National Controls manufacturing team gives you:

- *Skilled and well-trained work force*
- *Computer controlled and monitored production processes*
- *Computer driven testing systems*
- *Manufacturing processes using the latest technology and equipment*
- *Fully air conditioned manufacturing and storage environment*
- *On site screening process*
- *JIT parts support for your products*
- *MRP Planning system to support timely production of your controls*
- *Quality built into the product*
- *Suppliers that enhance quality and customer service*
- *All products fully tested to verify specification compliance*

Custom Design and Assembly

- *Surface mount fabrication capability*
- *Automatic insertion equipment*
- *Semi-automated hand insertion stations*
- *Wave soldering equipment*
- *Application specific test and burn-in equipment*
- *Computer based test systems providing manufacturing defect analysis*
- *Silkscreen and labeling capability*
- *In-process inspection and test*
- *100% final testing*

Serving Diverse and Demanding Partners in Industry

- *Compressor*
- *Generator*
- *Batch Processing*
- *Pump/Dispensing*
- *Fire Protection*
- *Packaging*
- *Automotive*
- *Environmental*



Opportunity



Customer Focus



Quality, Reliability,
Cost Competitiveness



Value-added Products



Long-term Relationships

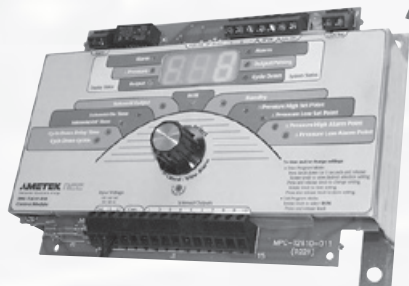
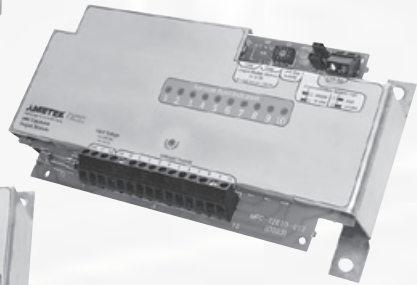

Our Quality System

AMETEK NCC has a Quality System that utilizes rigid control processes throughout the design, development, and manufacturing process to assure our customers of reliable products. AMETEK NCC justifies its claim of producing high quality products by placing emphasis on the following:

1. Design Review—As each product is conceived and its development is planned, detailed design criteria are thoroughly reviewed by Marketing, Design Engineering, Quality Assurance, Manufacturing, Product Test Engineering, and Product Service and Repair personnel to ensure all requirements are met.

2. Supplier Qualification—Every supplier of material that goes into AMETEK NCC products is evaluated for their capability to produce and deliver material according to specified requirements and must maintain an acceptable performance rating.

3. Incoming Inspection/Test—Materials received are inspected/tested to ensure they meet all required specifications.

4. In-Process Inspection/Testing—Inspection and testing occurs throughout the production process to verify the following:

- *Proper assembly and overall workmanship of products*
- *Products are calibrated, electrically tested for proper function and hi-pot per UL standards*
- *Life tested (products are burned-in to simulate actual operating conditions)*

5. Final Inspection/Test—Finished products are final inspected/tested to ensure compliance with all AMETEK NCC customer specifications.

6. Quality Audits—AMETEK NCC departments are audited for compliance with quality system requirements.

7. Standards Compliance—AMETEK NCC products are designed to comply with Underwriters Laboratory's, Canadian Standards Association's and the Federal Communications Commission's standard requirements for safety and emissions control. These activities are con-

ducted on a sample basis per MIL-STD-105E Sampling Standard. The measurement/test equipment used during all product stages are calibrated per AMETEK NCC's in-house process that conforms to MIL-STD-45662 Standard for Calibration Systems requirements.

8. Documentation—AMETEK NCC's Quality System is completely described in our Quality Assurance Manual which is available upon request along with our Product Workmanship Standard. Since all products are final inspected/tested after being 100% functionally tested during production, AMETEK NCC also offers a Certificate of Conformance, upon request, to customers desiring to minimize their internal process times by eliminating the need to perform an incoming inspection/test on AMETEK NCC products.

Total Quality Management

The above eight items highlight AMETEK NCC's Quality System. Together with marketing/sales, customer service, production planning, automated information systems, accounting/finance, corrective action, training, and statistical process control, they represent AMETEK NCC's **Total Quality Management** concept.

OVERVIEW	i
PRODUCT FINDER	vii
TIME DELAY RELAYS	1-1
Multi-Time Range/Function/Input Voltage	
Flatpak DMM Series.....	1-2
Multi-Time Range/Function/Input Voltage	
1/16 DIN TMM Series.....	1-3
Multi-Time Range/Function	
TMM Series.....	1-4
Multi-Time Range Delay On Make	
A1M Series	1-5
Delay On Make	
T1 Series	1-6
Delay On Make (Relay Output)	
Q1T Series.....	1-7
Delay On Make (Series Load)	
Q1T Series.....	1-8
Delay On Make (Series Load)	
Q1F Series.....	1-9
Delay On Make (Alarm Output)	
Q1F Alarm Series	1-10
Delay on Make (Series Load)	
Q1D Series	1-11
Delay On Make	
K1 Series	1-12
Delay On Make	
Z1 Series	1-13
Single Shot	
T2 Series	1-14
Single Shot	
Q2T Series.....	1-15
Single Shot	
Q2F Series.....	1-16
Single Shot	
K2 Series	1-17
Multi-Range Delay On Break (Retriggerable)	
T3M Series.....	1-18
Delay On Break (Retriggerable)	
T3 Series	1-19
Delay On Break (Retriggerable)	
Q3T Series.....	1-20
Delay On Break (Retriggerable)	
Q3F Series.....	1-21
Delay On Break (Retriggerable)	
K3 Series	1-22
Delay On Break (Retriggerable)	
Z3 Series	1-23
Interval	
S1 Series	1-24
Interval (Relay Output)	
Q4T Series.....	1-25
Interval	
Q4F Series.....	1-26
Interval	
Z4 Series	1-27
Repeat Cycle	
CKK Series.....	1-28
Repeat Cycle	
Q6F Series.....	1-29
Flasher	
Q8F Series.....	1-30
Repeat Cycle	
Z6 Series	1-31
Universal Voltage Input Buffer	
ASY-INPUT-BUFR	1-32
Fan and Light Control	
Model T1517	1-33
LIQUID LEVEL CONTROL SERIES	2-1
Resistance Sensors (Single Probe)	
05SLA and 05SLB Series.....	2-2
Resistance Sensors (Dual Probe)	
DLA and DLB Series.....	2-3

Resistance Sensors (Dual Probe)	
Models NS127, NS128 and NS143	2-4
Resistance Sensors (Pump Up Logic with Heater Burn Out Protection)	
Models NS210 and NS211	2-5
Resistance Sensors (Dual Probe)	
Models NS129, NS132 and NS139	2-6
Resistance Sensors (Dual Probe, Dual Logic)	
Model NS146	2-7
Resistance Sensors (Dual Probe, Dual Voltage)	
1hp Solid State Output	
Model NS141	2-8
Resistance Sensors (Single Probe, Pump Up Logic with Time Delayed Output)	
Models NS156 and NS159.....	2-9
Resistance Sensors (Low Water Detect Logic)	
Model NS157	2-10

TEMPERATURE MONITORS/CONTROLS 3-1	
Digital Temperature Controller	
TC140 Series.....	3-2
Digital Temperature Controller	
TC142 Series.....	3-4
Panel Mount Digital Thermometer	
Models TM165 and TM166	3-6
Digital Temperature Indicator	
TM110 Series	3-8
Digital Temperature Indicator	
TM200 Series	3-9
Electronic Temperature Controller	
TC280 Series.....	3-10

DUST COLLECTOR CONTROLS	4-1
Intermittent Use Collectors	
Model T2101	4-2
AC Input, Pulse Cleaning of Bag House Dust Collectors	
Models DNC-T2003 through DNC-T2032.....	4-4
DC Input, Pulse Cleaning of Bag House Dust Collectors	
Model DNC-T2010-ADC.....	4-6
Pulse Jet Dust Collector Control with Extended Cycle	
DNC-T2110 Series.....	4-8
DUSTRONIX™ Core-10/Expander-10 Dust Collector Controls	
Models DNC-T2610-010/020	4-10
DUSTRONIX™ Pressure Differential Meter*	
Model DNC-PS700-A10	4-12
Intelligent, AC-Input, Pulse Cleaning of Bag House Dust Collectors	
Models DNC-T2310 and DNC-T2320.....	4-14
Intelligent Dust Collector Controller Remote Input/Output Module	
Model DNC-T2300-I/O	4-20
Intelligent Dust Collector Controller Remote Annunciator Panel	
Model DNC-T2300-DSP	4-22

SOLID STATE RELAYS, VOLTAGE MONITORS, CURRENT MONITORS	5-1
Solid State Power Relays	
Model R2025	5-2
3-Phase Voltage Monitor	
Model 240T6	5-4
Single-Phase Undervoltage Monitors	
Models 120AZ and 240AZ.....	5-5
2-20 A Current Monitor	
IST-200T Series	5-6

GLOSSARY	6-1
-----------------------	------------

* May be purchased separately as an accessory to NCC Dust Collector Controls, as well as other controllers



Solid State Cube Timers and Time Delay Relays

OPERATING LOGIC	OUTPUT TYPE	PACKAGING CONSTRUCTION	MODEL	PAGE
Delay On Make	Relay SPDT	2" x 2" cube	Q1T Series (Relay Output)	1-7
	Solid state, Norm. Open	2" x 2" cube	Q1T Series (Series Load)	1-8
	Solid state, Norm. Open	2" x 2" cube	Q1D Series (Series Load)	1-11
	Solid state, Norm. Open	2" x 2" cube	Q1F Series (Series Load)	1-9
	Audible alarm	2" x 2" cube	Q1F Alarm Series	1-10
	Relay DPDT	8-pin plug in TDR housing	A1M Series	1-5
	Relay DPDT	8/11-pin plug in TDR housing	T1 Series	1-6
	Relay DPDT	Miniature spade plug in housing	K1 Series	1-12
Single Shot	Relay DPDT	Open board	Z1 Series	1-13
	Solid state, Norm. Open	2" x 2" cube	Q2T Series	1-15
	Solid state, Norm. Open	2" x 2" cube	Q2F Series	1-16
	Relay DPDT or SPDT	8/11-pin plug in TDR housing	T2 Series	1-14
Delay On Break (Retriggerable)	Relay DPDT	Miniature spade plug in housing	K2 Series	1-17
	Solid state, Norm. Open	2" x 2" cube	Q3T Series	1-20
	Solid state, Norm. Open	2" x 2" cube	Q3F Series	1-21
	Relay DPDT	11-pin plug in TDR housing	T3M Series	1-18
	Relay DPDT or SPDT	8/11-pin plug in TDR housing	T3 Series	1-19
	Relay DPDT	Miniature spade plug in housing	K3 Series	1-22
Interval	Relay DPDT	Open board	Z3 Series	1-23
	Relay SPDT	2" x 2" cube	Q4T Series	1-25
	Solid state, Norm. Open	2" x 2" cube	Q4F Series	1-26
	Relay DPDT	8-pin plug in TDR housing	S1 Series	1-24
Repeat Cycle	Relay DPDT	Open board	Z4 Series	1-27
	Solid state, Norm. Open	2" x 2" cube	Q6F Series	1-29
	Relay DPDT	8-pin plug in TDR housing	CKK Series	1-28
	Relay DPDT	Open board	Z6 Series	1-31
Multi-Function	Solid state, Norm. Open	2" x 2" cube	Q8F Series	1-30
	Relay DPDT	11-pin plug in TDR housing	TMM Series	1-4
	Relay DPDT	1/16 DIN panel mount, 11-pin spade type base	TMM Series	1-3
	Relay DPDT	DIN rail mount, Flatpak housing	DMM Series	1-2

Liquid Level Controls

OPERATING LOGIC	OUTPUT TYPE	PACKAGING CONSTRUCTION	MODEL	PAGE
Pump Down	Relay SPDT	Open board	NS127	2-4
	Relay SPDT	Open board	NS129	2-6
	Relay SPDT	Open board	NS139	2-6
	Solid state switch, Norm. Open, 16 A/1 hp	Open board	NS141 Series	2-8
	Relay SPDT	8-pin plug in TDR housing	DLA Series	2-3
Pump Up	Isolated relay SPDT	Open board	NS128	2-4
	Relay SPST, Norm. Open	Open board	NS143	2-4
	Relay SPDT	Open board	NS132	2-6
	Solid state switch, Norm. Open, 16 A/1 hp	Open board	NS141 Series	2-8
	Relay SPDT	8-pin plug in TDR housing	DLB Series	2-3
	Solid state switch, Norm. Open	Open board	NS156	2-9
	Relay SPST, Norm. Open	Open board	NS159	2-9
	Relay SPST	Open board	NS210	2-5
	Relay SPST	Open board	NS211	2-5
Relay SPDT	8-pin plug in TDR housing	05SLB Series	2-2	
Programmable Pump Down/Pump Up	Solid state switch, Norm. Open	Open board	NS146	2-7
Low Water Detect	Isolated relay SPDT	Open board	NS157	2-10

Temperature Controls

DESCRIPTION	OUTPUT TYPE	PACKAGING CONSTRUCTION	MODEL	PAGE
Digital Temperature Indicators	Digital display	Chassis mount	TM110 Series	3-8
		Panel mount	TM165/166	3-6
		Panel mount	TM200 Series	3-9
Digital Temperature Controllers/Timers	Relay SPST, Norm. Open, 1 A	Panel mount	TC140 Series	3-2
Digital Temperature Controllers	Relay SPST, Norm. Open, 1 A	Panel mount	TC142 Series	3-4
Electronic Temperature Controllers	Relay SPST, Norm. Open, 20 A	Back panel mount	TC280 Series	3-10

Dust Collector Controls

DESCRIPTION	MAX. OUTPUTS	INPUT VOLTAGE	MODEL	PAGE
Shaker, Intermittent Use	1	120 VAC	DNC-T2101-010/020	4-2
Pulse Cleaning, Continuous Mode or On Demand Mode	3	120 VAC	DNC-T2003-A10/B10	4-4
	6	120 VAC	DNC-T2006-A10/B10	
		220 VAC	DNC-T2006-A220/B220	
	10	120 VAC	DNC-T2010-A10/B10	
		220 VAC	DNC-T2010-A220/B220	
	20	120 VAC	DNC-T2020-A10/B10	
		220 VAC	DNC-T2020-A220/B220	
	32	120 VAC	DNC-T2032-A10/B10	
		220 VAC	DNC-T2032-A220/B220	
	10	12 to 24 VDC	DNC-T2010-ADC	
105 to 135 VAC		DNC-T2110 Series	4-8	
Main Control Module	10, expandable to 990	100 to 240 VAC	DNC-T2610-010	4-10
			DNC-T2610-020	
Pressure Differential Meter*	—	100 to 240 VAC	DNC-PS700-010	4-12
Pulse Cleaning, Intelligent Dust Collector Controller with Integral Pressure Sensor	10	105 to 135 VAC	DNC-T2310-A10/B10	4-14
		210 to 270 VAC	DNC-T2310-A220/B220	
	20	105 to 135 VAC	DNC-T2320-A10/B10	
		210 to 270 VAC	DNC-T2320-A220/B220	
Input/Output Board for use with Intelligent Dust Collector Controller	—	105 to 135 VAC	DNC-T2300-I/O	4-20
		210 to 270 VAC	DNC-T2301-I/O	
Remote Annunciator Panel with Intelligent Dust Collector Controller	1	105 to 135 VAC	DNC-T2300-DSP	4-22
		210 to 270 VAC	DNC-T2301-DSP	

* May be purchased separately as an accessory to NCC Dust Collector Controls, as well as other controllers

Solid State Relays, Voltage, and Current Monitors

DESCRIPTION	OUTPUT VOLTAGE	PACKAGING CONSTRUCTION	OUTPUT TYPE	MODEL	PAGE
Solid State Relay	48 to 300 VAC	1.75" x 2.25" x 1.0" encapsulated housing	Relay SPST, Norm. Open	SNC-R2025-501/507	5-2
			Relay SPST, Norm. Closed	SNC-R2025-511/517	
3-Phase Voltage Monitor	—	8-pin plug in TDR housing	Relay DPDT	PLC-240K6-44T	5-4
Single-Phase Undervoltage Monitor	—	2" x 2" cube	Relay SPDT	VNC-120AZ-341/ VNC-240AZ-345	5-5
2 to 20 A Current Monitor	—	2.5" x 3.5" x 1.375" encapsulated housing	Relay SPDT	IST-200T(A or Z)-141/145	5-6

Important Notice to Users

AMETEK NCC products are capable of use in a wide array of devices and in various applications. Any device or system incorporating an AMETEK NCC product should be so designed that, in the event of failure, malfunction, or normal wear-out of the product, the device or system will become inoperative in a manner which will prevent property damage or bodily injury.

In order to keep abreast of the latest technology, AMETEK NCC reserves the right to change components and/or design of controls without notice.

vii

PRODUCT FINDER

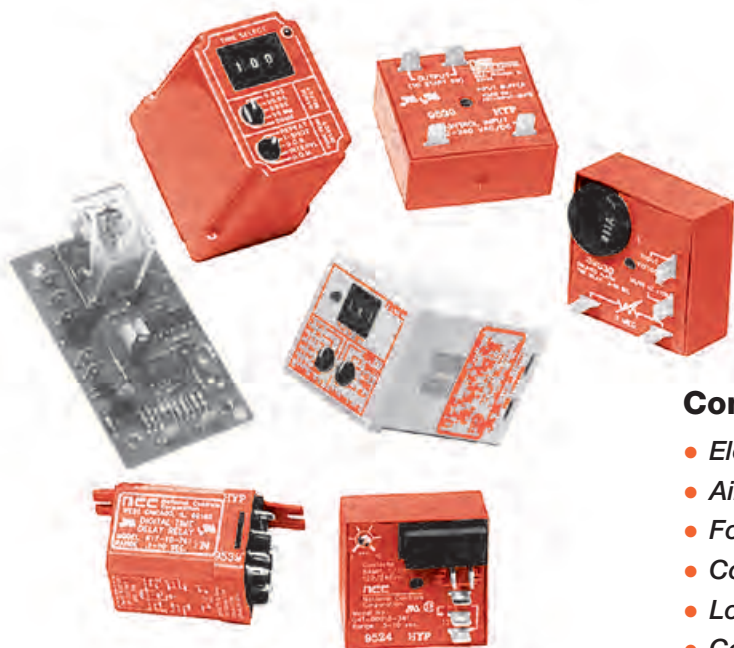

AMETEK NCC Time Delay Relays are versatile, reliable and available. These affordable solid state timers provide the MRO and OEM markets with dependable products that stand up to the rigorous demands of today's marketplace. The most common standard logic functions include the following: On Delay, Off Delay, Interval, One Shot and Repeat Cycle. Off-the-shelf ranges available are from 0.05 seconds to 999 hours with reliable load switching.

AMETEK NCC Time Delay Relays offer you a choice of sizes, shapes and terminations. Typical configurations are open-board, socket (8-pin, 11-pin and spade) and quick connect terminations. These highly accurate time delay relays are made for long-life, which is essential for your products performance.



In addition, AMETEK NCC offers impressive factory back-up support. Our parts inventory and product availability is unsurpassed. With over 250 stocking distributor outlets, serious downtime problems can virtually be eliminated. Technical assistance for design and engineering help is readily available through our **toll free number: 800-323-2593**.

Common Applications:

- *Electric Generator Sets*
- *Air Compressors*
- *Food Processing*
- *Compressed Air Dryers*
- *Loaders*
- *Conveyors*
- *Crushers and Pulverizers*
- *Dust Collection*
- *Home Alarm Systems*
- *Auto Alarm Systems*
- *Business Security Alarm Systems*
- *Packaging Equipment*
- *Injection Molding Equipment*
- *Coffee Brewers*
- *Commercial Air Conditioning*
- *Automated Animal Feeding*
- *Automated Fluid Spraying*
- *Aerators*
- *Agitators*
- *Bag/Box Dumping Equipment*
- *Bag Closing and Opening*
- *Batching Systems*
- *Compacting Equipment*
- *Extraction Equipment*
- *Extrusion Equipment*
- *Feed Mill Equipment*
- *Test Equipment*
- *Industrial Vacuum Cleaning*
- *Paper Shredders*
- *Medical Equipment*
- *Car Wash Equipment*
- *Crane and Hoist Operations*

Multi-Time Range/Function/Input Voltage Flatpak DMM Series

FEATURES

- 35mm DIN rail mount Flatpak enclosure
- Universal input voltage
- Microprocessor controlled timing circuit
- Five logic modes, user selectable
- Six time ranges, user selectable
- Time cycles from 0.05 seconds to 999 hours
- Easy 3-digit time cycle setting
- $\pm 0.1\%$ repeatability
- Timing light
- Superior transient protection
- UI 94VO plastic housing
-   File #E59090

The DMM Series offers selectable multiple time ranges, functional logic modes and universal input voltage range, all in one DIN rail mount space saving Flatpak enclosure.

Programming is accomplished by using two multi-position rotary switches. One switch selects one of six time ranges. The other switch selects one of five operating logic modes. A 3-digit push-button switch selects the amount of time required for a timing cycle.

SPECIFICATIONS

TIME DELAY

- Adjustment:** 3 digit push-button switch
- Range:** 50 ms to 999 hours in 6 ranges
- Repeatability:** $\pm 0.1\%$ of set time or ± 20 ms whichever is greater
- Accuracies:** All functions $\pm 1\%$ of set time or ± 20 ms whichever is greater

INPUT

- Operating Voltage:** 24 to 240 VAC $\pm 12\%$, 50/60 Hz; 24 to 240 VDC $\pm 12\%$, (DC unfiltered input voltage must be full-wave rectified)
- Power On Response:** 50 ms max.
- Power Off Reset Time:** Requires power interruption of 150 ms max. (50 ms typical)
- Start Switch Closure Time:** 50 ms. min. to initiate timing cycle; 50 ms. min. to reset delay during timing cycle
- Power Consumption:** 14 VA max. at 270 VAC, 2.5 VA max. at 24 VAC

OUTPUT

- Type:** Relay SPDT (1 form C)
- Rating:** 8 A max. resistive at 250 VAC, 5 A max. resistive at 30 VDC; 10 mA at 5 VDC min. load current
- Life:**
Mechanical: 10,000,000 operations
Full Load: 100,000 operations

ENVIRONMENTAL

- Storage Temperature:** -25°C to 70°C
- Operating Temperature:** -25°C to 55°C
- Humidity:** 95% relative

MECHANICAL

- Termination:** 6 screw terminals; Permissible wire size 22-12 gauge
- Mounting:** 35mm DIN rail mount
AMETEK NCC P/N for 3 foot section of 35 mm rail: MRL-SOCKET-011

Note: The DMM Series also mounts on 7.5 mm and 15 mm rails.

PROTECTION

- Transient Voltage:** 30 joule, 250 V metal oxide varistor
- Dielectric Breakdown:** 1800 VAC, RMS min. at 60 Hz between input and outputs and between outputs

TIMING LIGHT LOGIC

- Repeat Cycle:** Full on during OFF time; Flashing during ON time
- Other Logic Modes:** Flashing during timing; Full on after time out

TIMING

- Selectable Time Ranges:** 0.05 to 9.99 sec.; 0.1 to 99.9 sec.; 1 to 999 sec.; 0.1 to 99.9 minutes; 1 to 999 minutes; 1 to 999 hours (times less than 50 ms are not recommended due to the response time of the mechanical relay)

Selectable Operating Logic Modes:

- Repeat Cycle (50% fixed duty cycle)
- Single Shot (1 shot)
- Delay On Break (D.O.B.)
- Interval (Interval)
- Delay On Make (D.O.M.)

PROGRAMMING

To program the timer, remove voltage from the unit and select the operating logic mode and the time range; use the digital switches to select the required time (0 to 999)

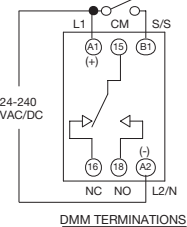
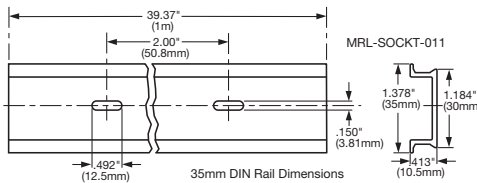
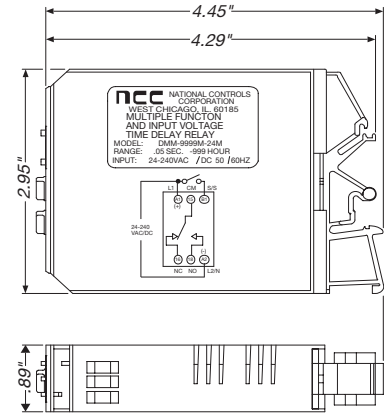
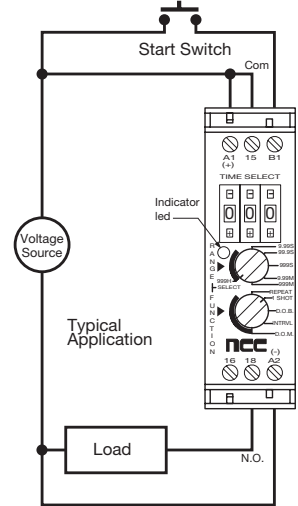
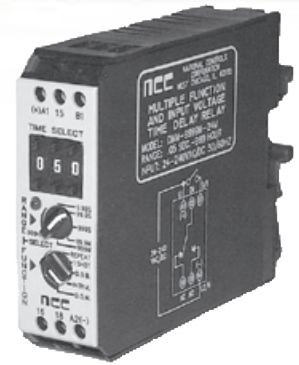



ORDERING INFORMATION

TIME RANGE	PART NUMBER	MOUNTING TYPE
0.05 sec. to 999 hrs.	DMM-9999M-24M	35 mm DIN rail
ACCESSORY	PART NUMBER	MOUNTING TYPE
35 mm, 3 ft DIN rail	MRL-SOCKET-011	Continuous screw slots

Multi-Time Range/Function/Input Voltage

1/16 DIN TMM Series

FEATURES

- 100% functionally tested
- 1/16 DIN panel mountable enclosure
- Universal input voltage
- Microprocessor controlled timing circuit
- Five logic modes, user selectable
- Six time ranges, user selectable
- Time cycles from 50 ms to 999 hours
- Easy 3-digit time cycle setting
- $\pm 0.1\%$ repeatability
- Timing light
- Superior transient protection
- Reinforced base locator pin
- Flame-retardant polycarbonate housing
-   File #E59090

The TMM Series offers selectable multiple time ranges, functional logic modes and universal input voltage range, all in one plug-in 1/16 DIN style panel mountable package.

Programming is accomplished by using two multi-position rotary switches. One switch selects one of six time ranges. The other switch selects one of five operating logic modes. A 3-digit push-button switch selects the amount of time required for a timing cycle.

Note: 1) Do not apply voltage or ground to the start switch, 2) Switch leads should be shielded when running close to other wires (Start switch supplied by customer)

SPECIFICATIONS

TIME DELAY

Adjustment: 3 digit push-button switch

Range: .05 seconds to 999 hours in 6 ranges

Repeatability: $\pm 0.1\%$ of set time or ± 20 ms whichever is greater

Accuracies: All functions $\pm 1\%$ of set time or ± 20 ms whichever is greater

INPUT

Operating Voltage: 24 to 240 VAC $\pm 15\%$, 50/60 Hz; 24 to 240 VDC $\pm 15\%$, (DC unfiltered input voltage must be full-wave rectified)

Power On Response: 50 ms max.

Power Off Reset Time: Requires power interruption of 150 ms max. (50 ms typical)

Start Switch Closure Time: 50 ms min. to initiate timing cycle; 50 ms min. to reset delay during timing cycle

Power Consumption: 14 VA max. at 276 VAC, 2.5 VA max. at 24 VAC

OUTPUT

Type: Relay DPDT (2 form C)

Rating: 10 A max. resistive at 240 VAC, 125 VDC
1/2 hp at 240 VAC; 10 mA at 5 VDC min. load current

Life:

Mechanical: 10,000,000 operations
Full Load: 500,000 operations

ENVIRONMENTAL

Storage Temperature: -25°C to 70°C

Operating Temperature: -25°C to 55°C

Humidity: 95% relative

MECHANICAL

Termination: 11-pin plug or spade type

Mounting:

Back Panel Mounting:

Spade Base use MSO-00KUP-012

11-pin Base use MSO-0011P-012

Front Panel Mounting: 1.78" sq. opening required

Front Panel Mounting Bracket MBK-1/16D-011

11-pin Base use MSO-0011P-013

PROTECTION

Transient Voltage: 7 joule, 250 V metal oxide varistor

Dielectric Breakdown: 1800 VAC, RMS min. at 60 Hz between input and outputs

TIMING LIGHT LOGIC

Repeat Cycle: Full On During OFF time

Flashing during ON time;

Other Logic Modes: Flashing during timing;

Full On after time out

TIMING

Selectable Time Ranges: .05 to 9.99 sec.; .1 to 99.9 sec.; 1 to 999 sec.; .1 to 99.9 minutes; 1 to 999 minutes; 1 to 999 hours (times less than 50 ms are not recommended due to the response time of the mechanical relay)

Selectable Operating Logic Modes:

Repeat Cycle (50% fixed duty cycle)

Single Shot (1 shot)

Delay On Break (D.O.B.)

Interval (Interval)

Delay On Make (D.O.M.)

PROGRAMMING

To program the timer, remove voltage from the unit and select the operating logic mode and the time range; use the digital switches to select the required time (0 to 999)

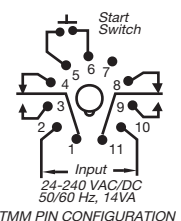
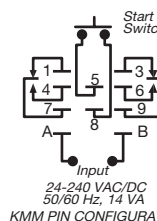
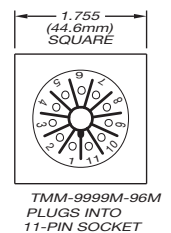
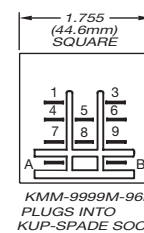
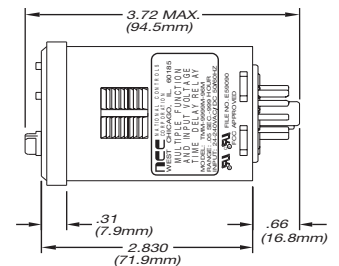
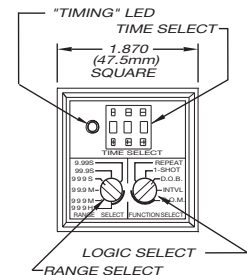



ORDERING INFORMATION

TIME RANGE	PART NUMBER	MOUNTING TYPE
0.05 sec. to 999 hrs.	TMM-9999M-96M	35 mm DIN rail
0.05 sec. to 999 hrs.	KMM-9999M-96M	Spade (.187" x .020" terminal) type plug-in base

Multi-Time Range/Function TMM Series

FEATURES

- 100% functionally tested
- Microprocessor controlled timing circuit
- Five logic modes, user selectable
- Five time ranges, user selectable
- Easy 3-digit time cycle setting
- $\pm 0.1\%$ repeatability
- Time cycles from 50 ms to over 16 hours
- Timing light
- Superior transient protection
- Reinforced base locator pin
- Flame-retardant polycarbonate housing
-   File #E59090

The TMM Series offers selectable multiple time ranges and functional logic modes all in one plug-in package.

Programming is accomplished by using two 5-position rotary switches. One switch selects one of five time ranges. The other switch selects one of five operating logic modes. A 3-digit push-button switch selects the amount of time required for a timing cycle.

SPECIFICATIONS

TIME DELAY

- Adjustment:** 3 digit push-button switch
Range: 50 ms to 999 minutes in 5 ranges
Repeatability: $\pm 0.1\%$, ± 0.02 seconds over specified timing range

ACCURACIES

- Delay On Make:** $\pm 1\%$ of set time, plus fixed error of 80 ms max. (40 ms typical including power-on response time)
Interval, One shot: $\pm 1\%$ of set time, plus fixed error of 35 ms max. (10 ms typical)
Delay On Break: $\pm 1\%$ of set time, plus fixed error of 75 ms max. (10 ms typical)
Repeat Cycle, On Time: $\pm 1\%$ of set time, plus fixed error of 35 ms max. (10 ms typical)
Repeat Cycle, Off Time: $\pm 1\%$ of set time, minus error of 65 ms max. (10 ms typical)

INPUT

Operating Voltage: 24, 120, 240 VAC; 12, 24, 48 VDC $\pm 10\%$ (DC models have reverse polarity protection. Unfiltered input voltage to them must be full-wave rectified)

- Power On Response:** .05 sec. max.
Power Off Reset Time: .15 sec. min.
Start Switch Closure Time: .020 sec. to initiate timing cycle; .050 sec. to reset delay during timing cycle
Power Consumption: 2 VA max.
Frequency: 50/60 Hz

OUTPUT

- Type:** Relay DPDT (2 form C)
Rating: 10 A max. resistive at 240 VAC; 100 mA at 5 VDC min. load current

- Life:**
 Mechanical: 10,000,000 operations
 Full Load: 500,000 operations

TIMING LIGHT LOGIC

- Repeat Cycle:** Flashing during ON time; Full On during OFF time
Other Logic Modes: Flashing during timing; continuously on after time out

PROTECTION

- Transient Voltage:** 12, 24, 48 V timers are protected by an 8.8 joule metal oxide varistor; 120, 240 V timers are protected by a 30 joule metal oxide varistor
Dielectric Breakdown: 1500 VAC, RMS min. at 60 Hz between input and outputs and between outputs

MECHANICAL

- Termination:** 11-pin plug
Mounting: Socket mount, part number MSO-0011P-012

ENVIRONMENTAL

- Storage Temperature:** -23°C to 70°C
Operating Temperature: -23°C to 55°C
Humidity: 95% relative

TIMING

- Selectable Time Ranges:** .05 to 9.99 seconds; .1 to 99.9 seconds; 1 to 999 seconds; .1 to 99.9 minutes; 1 to 999 minutes (times less than 50 ms are not recommended due to the response time of the mechanical relay)

Selectable Operating Logic Modes:

- Repeat Cycle (50% fixed duty cycle)
 Single Shot (1 shot)
 Delay On Break (D.O.B.)
 Interval (Interval)
 Delay On Make (D.O.M.)

PROGRAMMING

To program the timer, remove voltage from the unit and select the operating logic mode and the time range; use the digital switches to select the required time (0 to 999)

- Note: 1) Do not apply voltage or ground to the Start switch,
 2) Switch leads should be shielded when running close to other wires (Start switch supplied by customer)*

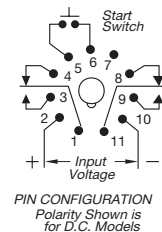
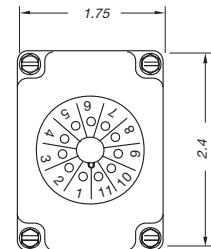
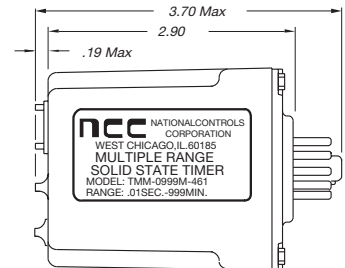
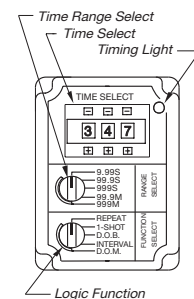

ORDERING INFORMATION

TIME RANGE	12 VDC	24 VDC	48 VDC	24 VAC	120 VAC	240 VAC
.05 sec. to 999 min.	TMM-0999M-466	TMM-0999M-462	TMM-0999M-464	TMM-0999M-467	TMM-0999M-461	TMM-0999M-465

Multi-Time Range Delay On Make A1M Series

FEATURES

- 100% functionally tested
- Microprocessor controlled timing circuit
- Five time ranges, user selectable
- Easy 3-digit time cycle setting
- $\pm 0.1\%$ repeatability
- Time cycles from 50 ms to over 16 hours
- Timing light
- Superior transient protection
- Reinforced base locator pin
- Flame-retardant polycarbonate housing
- File #E59090

The A1M Series is a Delay On Make time delay relay featuring easy to program multiple time ranges and digital time selection with extremely high accuracy and repeatability.

Programming is accomplished using a 5 position rotary switch to select one of five time ranges. A 3-digit push-button switch selects the amount of time delay required.

Operating Logic: Upon application of voltage to the input terminals, the time delay is initiated. At the end of the preset time delay, the relay coil is energized and the contacts transfer. Reset is accomplished by the removal of input voltage.

LOGIC FUNCTION DIAGRAM

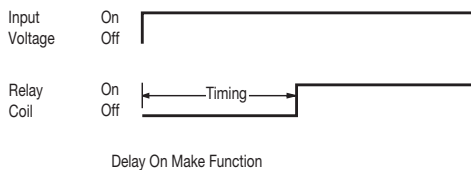

SPECIFICATIONS

TIME DELAY

- Adjustment:** 3 digit push-button switch
Range: 50 ms to 999 minutes in 5 ranges
Repeatability: $\pm 0.1\%$, ± 0.02 seconds over specified timing range

ORDERING INFORMATION

TIME RANGE	12 VDC	24 VDC	24 VAC	120 VAC	240 VAC
.05 sec. to 999 min.	A1M-0999M-466	A1M-0999M-462	A1M-0999M-467	A1M-0999M-461	A1M-0999M-465

Accuracy: $\pm 1\%$ of set time, plus fixed error of 80 ms max. (40 ms typical including power on response time)

INPUT

Operating Voltage: 24, 120, 240 VAC; 12, 24, VDC $\pm 10\%$ (DC models have reverse polarity protection. Unfiltered input voltage to them must be full-wave rectified)

Power On Response: .05 sec. max.

Power Off Reset Time: .15 sec. min.

Power Consumption: 2 VA max.

Frequency: 50/60 Hz

OUTPUT

Type: Relay DPDT (2 form C)

Rating: 10 A max. resistive at 240 VAC; 100 mA at 5 VDC min. load current

Life:

Mechanical: 10,000,000 operations

Full Load: 500,000 operations

TIMING LIGHT LOGIC

Repeat Cycle: Flashing during timing; continuously ON after time out

PROTECTION

Transient Voltage: 12V, 24V timers are protected by an 8.8 joule metal oxide varistor; 120, 240 V timers are protected by a 30 joule metal oxide varistor

Dielectric Breakdown: 1500 VAC, RMS min. at 60 Hz between input and outputs and between outputs

MECHANICAL

Termination: 8-pin plug

Mounting: Socket mount, part number MSO-0008P-012

ENVIRONMENTAL

Storage Temperature: -23°C to 70°C

Operating Temperature: -23°C to 55°C

Humidity: 95% relative

TIMING

Selectable Time Ranges: .05 to 9.99 seconds; .1 to 99.9 seconds; 1 to 999 seconds; .1 to 99.9 minutes; 1 to 999 minutes (times less than 50 ms are not recommended due to the response time of the mechanical relay)

PROGRAMMING

To program the timer, remove power from the unit and select the time range; use the digital switches to select the required time (0 to 999)

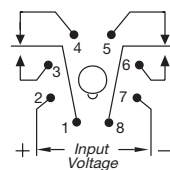
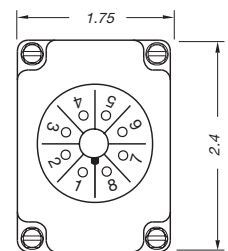
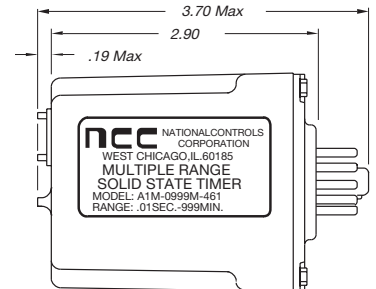
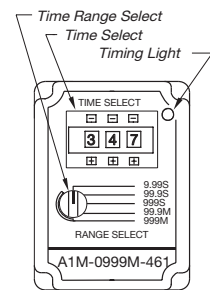

PIN CONFIGURATION
Polarity Shown is for D.C. Models

1-6 TIME DELAY RELAYS

Delay On Make T1 Series

FEATURES

- 100% functionally tested
- Digital timing circuit
- ±1% repeatability
- Time calibrated dial
- Superior transient protection
- Fiberglass reinforced circuit board
- Internal components supported by heavy-duty chassis
- Reinforced base locator pin
- Flame-retardant polycarbonate housing
- File #E59090

Operating Logic: Upon application of voltage to the input terminals, the time delay cycle starts. At the end of the preset time delay, the relay coil is energized and the contacts transfer. Reset is accomplished by the removal of input voltage.

Note: 1) Remote potentiometer leads should be shielded when running close to other wires; 2) The minimum time setting on external resistor-adjustable time delay relays is obtained by shorting together the external resistor terminals of the relay; 3) The maximum time setting within tolerance limits is obtained by using a 1 megohm resistor; 4) Timing values between the minimum and maximum limits are linear with resistance within 10%; 5) Recommend 1/4 W minimum resistor be used.

LOGIC FUNCTION DIAGRAM

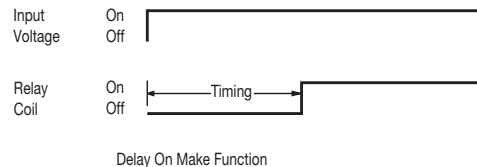

SPECIFICATIONS

TIME DELAY

Adjustment: Knob or external resistor, factory fixed on special order (min. order required)

Range: 50 ms to 1 hour in 8 ranges

Repeatability: ±1% at constant temperature

Accuracy: Maximum time -0%, +10%; Minimum time +0%, -50%

Reset Time: 50 ms max. (25 ms typical)

INPUT

Operating Voltage: 24, 120, 240 VAC; 12, 24 VDC ±10% (DC models have reverse polarity protection. Unfiltered input voltage to them must be full-wave rectified)

Power Consumption: 3 VA max.

Frequency: 50/60 Hz

OUTPUT

Type: Relay contacts, DPDT (2 form C)

Rating: 10 A max. resistive at 240 VAC; 100 mA at 5 VDC min. load current

Life:

Mechanical: 10,000,000 operations

Full Load: 500,000 operations

PROTECTION

Transient Voltage: 12, 24 V timers are protected by an 8.8 joule metal oxide varistor; 120, 240 V timers are protected by a 30 joule metal oxide varistor

Dielectric Breakdown: 1500 VAC, RMS min. at 60 Hz between input and outputs and between outputs

MECHANICAL

Termination: 8-pin or 11-pin plug

Mounting: Socket mount, 8-pin part number MSO-0008P-012; Socket mount, 11-pin part number MSO-0011P-012

ENVIRONMENTAL

Storage Temperature: -23°C to 70°C

Operating Temperature: -23°C to 55°C

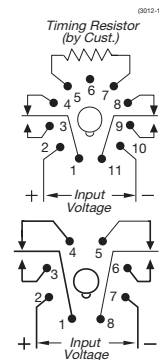
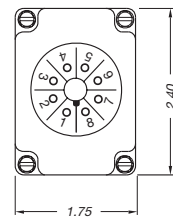
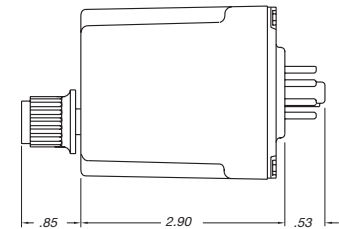

PIN CONFIGURATION
Polarity Shown is
for D.C. Models

ORDERING INFORMATION

TIME RANGE	12 VDC KNOB ADJST. 8-PIN BASE	24 VDC KNOB ADJST. 8-PIN BASE	24 VAC KNOB ADJST. 8-PIN BASE	120 VAC KNOB ADJST. 8-PIN BASE	120 VAC REMOTE POT 11-PIN BASE	240 VAC KNOB ADJST. 8-PIN BASE
.05 to 1 sec.	—	—	—	T1K-00001-461	—	—
.1 to 10 sec.	T1K-00010-466	T1K-00010-462	T1K-00010-467	T1K-00010-461	T1F-00010-461*	T1K-00010-465
.3 to 30 sec.	T1K-00030-466	—	—	T1K-00030-461	—	—
.6 to 60 sec.	T1K-00060-466	T1K-00060-462	T1K-00060-467	T1K-00060-461	T1F-00060-461*	T1K-00060-465
1.8 to 180 sec.	—	—	—	T1K-00180-461	—	—
3 to 300 sec.	—	—	—	T1K-00300-461	—	—
6 to 600 sec.	—	—	—	T1K-00600-461	—	—
36 to 3600 sec.	—	—	—	T1K-03600-461	—	—

* Optional Potentiometer: Part Number ASY-0001M-450

External Resistance/Time Delay Relationship

1 megohm external resistance is required to obtain the maximum time for all ranges. To determine the actual resistance needed to obtain the required time delay, use the following formula:

$$R_t = \frac{\text{Required} - \text{Tmininum}}{\text{Tmaximum} - \text{Tmininum}} \times 1,000,000 \text{ ohms}$$

Note: Due to component tolerances, the actual time obtained will normally be within 5% of desired time.

Consult factory for any special requirements not listed in catalog (minimum order requirement may apply).

Delay On Make (Relay Output)

Q1T Series

FEATURES

- Time delays to 10 hours standard
- Solid state digital timing
- 100% functionally tested
- 20:1 maximum to minimum timing ratio
- Sealed SPDT output contacts
- Compact size
- Superior transient protection
- Epoxy encapsulated
- Flame-retardant and solvent-resistant polyester thermoplastic housing
- Trimpot on-board with sealed cermet element
-  File #E65038

Operating Logic: Upon application of voltage to the input terminals L1, L2, the time delay is initiated. At the end of the preset time delay, the relay coil is energized and the contacts transfer. Reset is accomplished by removing voltage from the input terminals.

LOGIC FUNCTION DIAGRAM

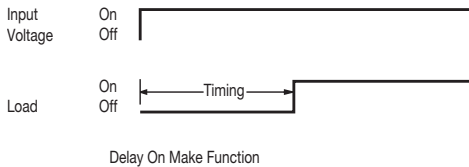

SPECIFICATIONS

TIME DELAY

Adjustment: On-board Trimpot
Range: 50 ms to 10 hours in 9 ranges
Repeatability: $\pm 5\%$ max. (0.25% typical) at constant temperature
Accuracy: Max. time +10%, -0%; Minimum time -30%, +0%
Reset Time: .25 seconds max., by removal of the input voltage

INPUT

Operating Voltage: 12 VDC, 24 VAC/DC, 120 VAC/DC $\pm 10\%$
Power Consumption: 3.5 VA max.
Frequency: 50/60 Hz

OUTPUT

Type: Relay contacts, SPDT (1 form C)
Rating: 8 A max. resistive at 250 VAC and 30 VDC; 100 mA at 5 VDC min. load current
Life:
 Mechanical: 10,000,000 cycles
 Electrical: 100,000 min. at full load

PROTECTION

Transient Voltage: 1000 P.I.V. components used
Isolation Resistance: 100 megohms min. between terminals and case
Dielectric Breakdown: 3000 VAC, RMS, terminals to mounting; 1500 VAC, RMS, input to output

MECHANICAL

Termination: .25" x .032" male fast-on terminals
Mounting: Surface mount with one #8 screw

ENVIRONMENTAL

Storage Temperature: -40°C to 70°C
Operating Temperature: -40°C to 70°C
Humidity: 95% relative

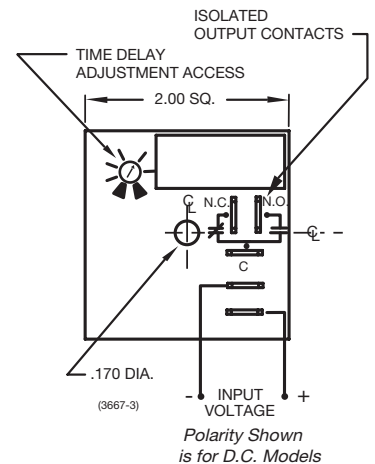
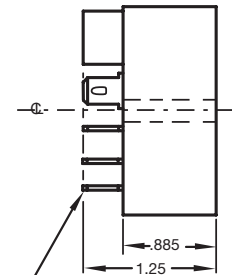

ORDERING INFORMATION

TIME RANGE	12 VDC $\pm 10\%$	24 VAC/DC $\pm 10\%$	120 VAC/DC $\pm 10\%$
.05 to 1 sec.	—	—	Q1T-00001-341
.25 to 5 sec.	—	—	Q1T-00005-341
.5 to 10 sec.	—	Q1T-00010-347	Q1T-00010-341
3 to 60 sec.	Q1T-00060-346	—	Q1T-00060-341
15 to 300 sec.	Q1T-00300-346	—	Q1T-00300-341
30 to 600 sec.	—	—	Q1T-00600-341
180 to 3600 sec.	—	—	Q1T-03600-341
.25 to 5 hrs.	—	—	Q1T-18000-341
.5 to 10 hrs.	—	—	Q1T-36000-341

Consult factory for any special requirements not listed in catalog (minimum order requirement may apply).

Delay On Make (Series Load)

Q1T Series

FEATURES

- 100% functionally tested
- Solid state digital timing
- 20:1 maximum to minimum timing ratio
- Compact size
- Low cost
- Superior transient protection
- Epoxy encapsulated
- Flame-retardant and solvent-resistant polyester thermoplastic housing
- Trimpot on-board with sealed cermet element
-  File #E65038

Operating Logic: Upon application of input voltage, the time delay starts. At the end of the time delay, the load is energized. Reset is accomplished by removing input voltage.

Note: The load may be located on either side of the line

LOGIC FUNCTION DIAGRAM

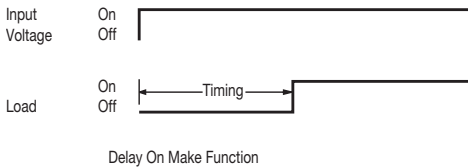

SPECIFICATIONS

TIME DELAY

Adjustment: On-board Trimpot

Range: 50 ms to 10 hours in 9 ranges

Repeatability: $\pm 0.5\%$ +8 ms max. (0.25% typical) at constant temperature

Accuracy: Maximum time -0%, +10%; Minimum time -30%, +0%

INPUT

Operating Voltage: 12, 24, 120, 240 VAC/DC $\pm 10\%$ (on DC models, unfiltered supply voltage must be full-wave rectified)

Frequency: 50/60 Hz

OUTPUT

Type: Solid state normally open series load

Rating: Maximum current -1 A AC/DC (resistive or inductive)

Life: 100,000,000 operations

PROTECTION

Transient Voltage: Metal oxide varistor (see ratings below)

Dielectric Breakdown: 3000 VAC, RMS, terminals to mounting

Isolation Resistance: 100 megohms min. between terminals and case

MECHANICAL

Termination: .25" x .032" male fast-on terminals

Mounting: Surface mount with one #8 screw

ENVIRONMENTAL

Storage Temperature: -40°C to 85°C

Operating Temperature: -40°C to 65°C

Humidity: 95% relative



.25 X .032 MALE FAST-ON TERMINALS (4 PL.)

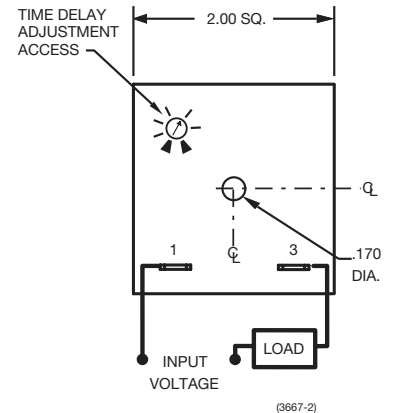
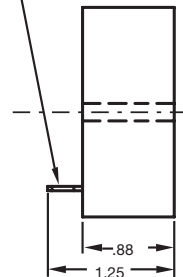

ORDERING INFORMATION

TIME RANGE	12 VAC/DC $\pm 10\%$	24 VAC/DC $\pm 10\%$	120 VAC/DC $\pm 10\%$	240 VAC/DC $\pm 10\%$
.05 to 1 sec.	Q1T-00001-316	Q1T-00001-317	Q1T-00001-311	Q1T-00001-315
.25 to 5 sec.	Q1T-00005-316	Q1T-00005-317	Q1T-00005-311	Q1T-00005-315
.5 to 10 sec.	Q1T-00010-316	Q1T-00010-317	Q1T-00010-311	Q1T-00010-315
3 to 60 sec.	Q1T-00060-316	Q1T-00060-317	Q1T-00060-311	Q1T-00060-315
15 to 300 sec.	Q1T-00300-316	Q1T-00300-317	Q1T-00300-311	Q1T-00300-315
30 to 600 sec.	Q1T-00600-316	Q1T-00600-317	Q1T-00600-311	Q1T-00600-315
180 to 3600 sec.	Q1T-03600-316	Q1T-03600-317	—	—
.5 to 10 hrs.	Q1T-36000-316	—	—	—

TIME RANGE	24 to 240 VAC/DC $\pm 10\%$
24 to 480 sec.	Q1T-00480-31M

	12 VAC/DC $\pm 10\%$	24 VAC/DC $\pm 10\%$	120 VAC/DC $\pm 10\%$	240 VAC/DC $\pm 10\%$
Reset time, during timing	125 ms	125 ms	125 ms	125 ms
Reset time, after timeout	10 ms	10 ms	10 ms	10 ms
Min. load	10mA DC, 60 mA AC	10mA DC, 40 mA AC	10 mA	10 mA
Max. leakage current	2 mA	4 mA	2 mA	2 mA
Voltage drop at 1 A	3.3 V max.	3.3 V max.	3.3 V max.	3.3 V max.
Power consumption	0.25 VA max.	0.25 VA max.	0.5 VA max.	0.5 VA max.
Peak 1 cycle surge	4 A	4 A	20 A	20 A
Protection	8.8j. MOV	8.8j. MOV	30j. MOV	30j. MOV

Consult factory for any special requirements not listed in catalog (minimum order requirement may apply).

Delay On Make (Series Load)

Q1F Series

FEATURES

- 100% functionally tested
- Time delays to 10 hours standard
- Solid state digital timing
- 20:1 maximum to minimum timing ratio
- Compact size
- Low cost
- Superior transient protection
- Flame-retardant and solvent-resistant polyester thermoplastic housing
- File #E65038

Operating Logic: Upon application of input voltage, the delay starts. At the end of the time delay, the load is energized. Reset is accomplished by removing input voltage.

Note: 1) The load may be located on either side of the line; 2) Remote potentiometer leads should be shielded when running close to other wires; 3) The minimum time setting on external resistor-adjustable time delay relays is obtained by shorting together the external resistor terminals of the relay; 4) The maximum time setting within tolerance limits is obtained by using a 1 megohm resistor; 5) Timing values between the minimum and maximum limits are linear with resistance within 10%; 6) Recommend 1/4 W minimum resistor be used.

LOGIC FUNCTION DIAGRAM

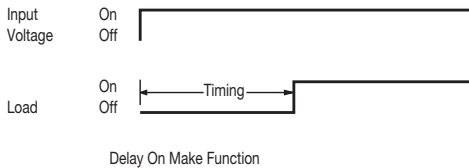

ORDERING INFORMATION

TIME RANGE	12 VAC/DC ±10%	24 VAC/DC ±10%	120 VAC/DC ±10%	240 VAC/DC ±10%
.05 to 1 sec.	Q1F-00001-316	Q1F-00001-317	Q1F-00001-311	—
.25 to 5 sec.	Q1F-00005-316	Q1F-00005-317	Q1F-00005-311	Q1F-00005-315
.5 to 10 sec.	Q1F-00010-316	Q1F-00010-317	Q1F-00010-311	—
3 to 60 sec.	Q1F-00060-316	Q1F-00060-317	Q1F-00060-311	—
15 to 300 sec.	Q1F-00300-316	Q1F-00300-317	Q1F-00300-311	Q1F-00300-315
30 to 600 sec.	—	—	Q1F-00600-311	—
180 to 3600 sec.	Q1F-03600-316	Q1F-03600-317	Q1F-03600-311	Q1F-03600-315
.25 to 5 hrs.	Q1F-18000-316	Q1F-18000-317	Q1F-18000-311	—
.5 to 10 hrs.	Q1F-36000-316	—	Q1F-36000-311	Q1F-36000-315

Reset time, during timing	125 ms	125 ms	125 ms	125 ms
Reset time, after timeout	10 ms	10 ms	10 ms	10 ms
Min. load	10mA DC, 60 mA AC	10mA DC, 40 mA AC	10 mA	10 mA
Max. leakage current	2 mA	4 mA	2 mA	2 mA
Voltage drop at 1 A	3.3 V max.	3.3 V max.	3.3 V max.	3.3 V max.
Power consumption, during timing	0.25 VA max.	0.25 VA max.	0.5 VA max.	0.5 VA max.
Power consumption, after timeout	3.0 VA max.	3.0 VA max.	3.0 VA max.	3.0 VA max.
Peak 1 cycle surge	20 A	20 A	20 A	20 A
Protection	8.8j. MOV	8.8j. MOV	30j. MOV	30j. MOV

Optional Potentiometer: Part Number ASY-0001M-450

SPECIFICATIONS

TIME DELAY

Adjustment: External resistor, factory fixed on special order (min. order requirement)
Range: 50 ms to 10 hours in 9 ranges
Repeatability: ±.5% +8 ms max. (0.25% typical) at constant temperature
Accuracy: Maximum time ±2% at Rt = 1 megohms; Minimum time +0%, -30% at Rt = 0 ohm

INPUT

Operating Voltage: 12, 24, 120, 240 VAC/DC ±10% (on DC models, unfiltered supply voltage must be full-wave rectified)
Frequency: 50/60 Hz

OUTPUT

Type: Solid state, normally open series load
Rating: 1 A steady state max.
Life: 100,000,000 operations

PROTECTION

Transient Voltage: Metal oxide varistor, see ratings below
Dielectric Breakdown: 3000 VAC, RMS, terminals to mounting
Insulation Resistance: 100 megohms min. between terminals and case

MECHANICAL

Termination: .25" x .032" male fast-on terminals
Mounting: Surface mount with one #8 screw

ENVIRONMENTAL

Storage Temperature: -40°C to 85°C
Operating Temperature: -40°C to 85°C
Humidity: 95% relative

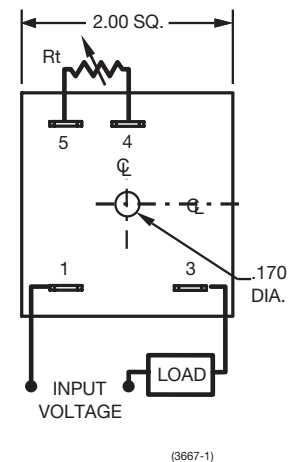
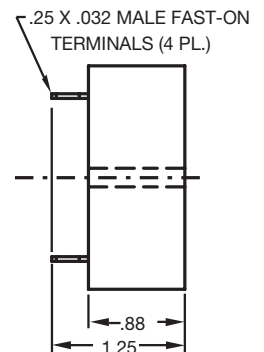

External Resistance/Time Delay Relationship

1 megohm external resistance is required to obtain the maximum time for all ranges. To determine the actual resistance needed to obtain the required time delay, use the following formula:

$$R_t = \frac{\text{Required} - T_{\text{minimum}}}{T_{\text{maximum}} - T_{\text{minimum}}} \times 1,000,000 \text{ ohms}$$

Note: Due to component tolerances, the actual time obtained will normally be within 5% of desired time.

Consult factory for any special requirements not listed in catalog (minimum order requirement may apply).

1-10 TIME DELAY RELAYS

Delay On Make (Alarm Output) Q1F Alarm Series

FEATURES

- 100% functionally tested
- Time delays to 10 hours standard
- Loud audio alarm for use in noisy environments
- Solid state digital timing
- 20:1 maximum to minimum timing ratio
- Low cost
- Compact size
- Superior transient protection
- Flame-retardant and solvent-resistant polyester thermoplastic housing
- File #E165149

The Q1F Delay to Alarm Cube Timer is intended for use as a Delay On Make audible alarm.

Operating Logic: Upon application of the input voltage, the time delay starts. At the end of the preset time delay the audible alarm is activated. Reset is accomplished by removing input voltage.

Note: 1) Remote potentiometer leads should be shielded when running close to other wires; 2) The minimum time setting on external resistor-adjustable time delay relays is obtained by shorting together the external resistor terminals of the relay; 3) The maximum time setting within tolerance limits is obtained by using a 1 megohm resistor; 4) Timing values between the minimum and maximum limits are linear with resistance within 10%; 5) Recommend 1/4 W minimum resistor be used.

LOGIC FUNCTION DIAGRAM

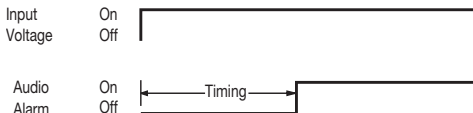

Delay On Make Function

SPECIFICATIONS

TIME DELAY

Adjustment: External resistor, factory fixed on special order (min. order requirement)

Range: 50 ms to 10 hours in 9 ranges

Repeatability: ±.5% +8 ms max. (0.25% typical) at constant temperature

Accuracy: Max. +0%, -30% at Rt = 0 ohm

Reset Time:

During Timing: 300 ms

After Timeout: 150 ms

INPUT

Operating Voltage: 120 or 240 VAC ±10%

Frequency: 50/60 Hz

OUTPUT

Type: Solid state Piezo Audio Alarm

Alarm Frequency: 3.15 kHz ±0.5 kHz

Sound Pressure Level: 76 dB at 1 meter

Life: 10,000,000 operations

PROTECTION

Transient Voltage: Metal oxide varistor

Dielectric Breakdown: 3000 VAC, RMS, terminals to mounting

Insulation Resistance: 100 megohms min. between terminals and case

MECHANICAL

Termination: .25" x .032" male fast-on terminals

Mounting: Surface mount with one #8 screw

ENVIRONMENTAL

Storage Temperature: -40°C to 75°C

Operating Temperature: 0°C to 65°C

Humidity: 95% relative



.25 X .032 MALE FAST-ON TERMINALS (5 PL.)

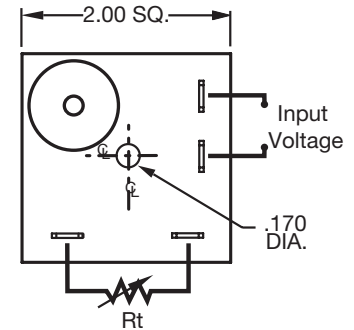
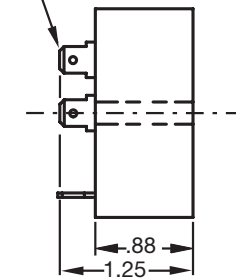

ORDERING INFORMATION

TIME RANGE	120 VAC 50/60 Hz	240 VAC 50/60 Hz
.05 to 1 sec.	—	Q1F-00001-3A5
.25 to 5 sec.	—	Q1F-00005-3A5
.5 to 10 sec.	—	Q1F-00010-3A5
3 to 60 sec.	Q1F-00060-3A1	Q1F-00060-3A5
15 to 300 sec.	—	Q1F-00300-3A5
30 to 600 sec.	—	Q1F-00600-3A5
180 to 3600 sec.	Q1F-03600-3A1	Q1F-03600-3A5
.25 to 5 hrs.	Q1F-18000-3A1	Q1F-18000-3A5
.5 to 10 hrs.	Q1F-36000-3A1	Q1F-36000-3A5

Optional Potentiometer: Part Number ASY-0001M-450

External Resistance/Time Delay Relationship

1 megohm external resistance is required to obtain the maximum time for all ranges. To determine the actual resistance needed to obtain the required time delay, use the following formula:

$$R_t = \frac{\text{Required} - \text{Tminimum}}{\text{Tmaximum} - \text{Tminimum}} \times 1,000,000 \text{ ohms}$$

Note: Due to component tolerances, the actual time obtained will normally be within 5% of desired time.

Consult factory for any special requirements not listed in catalog (minimum order requirement may apply).

Delay on Make (Series Load)

Q1D Series

FEATURES

- 100% functionally tested
- Time delay from 1 to 1023 seconds in 1 second increments
- Universal input voltage 24 to 240 VAC/DC
- Solid state digital timing
- Low cost
- Compact size
- Superior transient protection
- Flame-retardant and solvent-resistant polyester thermoplastic housing
- File #E65038

Allows user to accurately set delay times up to 1023 seconds without time consuming trial and error adjustments.

Operating Logic: Upon application of input voltage, the delay starts. At the end of the time delay, the load is energized. Reset is accomplished by removing input voltage. Set the delay time by switching the appropriate combination of time values to the ON position.

Note: The load may be located on either side of the line

LOGIC FUNCTION DIAGRAM

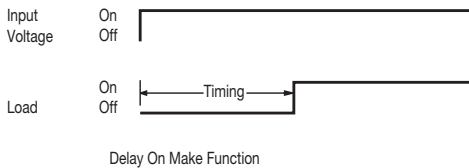

SPECIFICATIONS

TIME DELAY

Adjustment: 10 position DIP switch

Range: 1 to 1023 seconds in one second increments. Zero time setting is undefined.

Repeatability: $\pm 0.5\%$ (0.25% typical) at constant temperature

Accuracy: $\pm 10\%$ of set time +0.25 second

INPUT

Operating Voltage: 24 to 240 VAC/DC $\pm 10\%$ (on voltage must be full-wave rectified)

Frequency: 50/60 Hz

OUTPUT

Type: Solid state, normally open series load

Rating: 1 A steady state max.

Life: 100,000,000 operations

PROTECTION

Transient Voltage: 30 joule metal oxide varistor

Dielectric Breakdown: 3000 VAC, RMS, terminals to mounting

Insulation Resistance: 100 megohms min. between terminals and case

MECHANICAL

Termination: .25" x .032" male fast-on terminals

Mounting: Surface mount with one #8 screw

ENVIRONMENTAL

Storage Temperature: -40°C to 85°C

Operating Temperature: -40°C to 65°C

Humidity: 95% relative

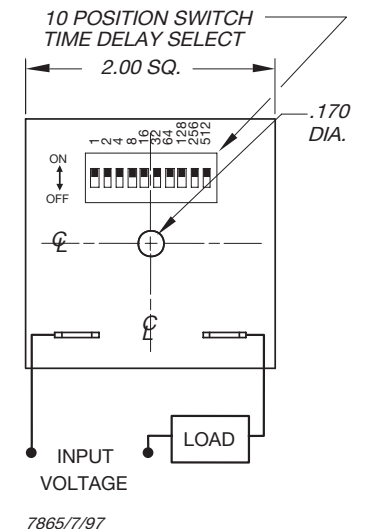
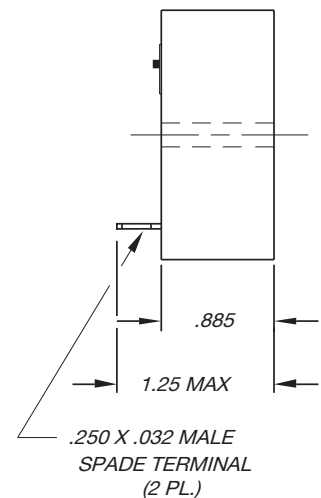

ORDERING INFORMATION

TIME RANGE	24 to 240 VAC/DC $\pm 10\%$
1 to 1023 sec.	Q1D-01024-31M
Reset time, during timing	125 ms
Reset time, after timeout	10 ms
Min. load	10mA or 1 VA, whichever is greater
Max. leakage current	2 mA
Voltage drop at 1 A	3.3 V max.
Power consumption, during timing	0.25 VA max.
Power consumption, after timeout	3.3 VA max.
Peak 1 cycle surge	20 A
Protection	30j. MOV

Delay On Make K1 Series

FEATURES

- 100% functionally tested
- No false contact transfer when reset during timing
- Digital timing circuit
- Time delays to 5 minutes
- Low cost
- Compact size
- Spade type base
- Wide operating temperature range
- Fiberglass reinforced circuit board
- Polycarbonate, 94V-2 housing material
- File #E59090

Operating Logic: Upon application of voltage to the input terminals, the time delay cycle starts. At the end of the preset time delay, the relay coil is energized and the contacts transfer. Reset is accomplished by the removal of input voltage.

Note: 1) Remote potentiometer leads should be shielded when running close to other wires; 2) The minimum time setting on external resistor-adjustable time delay relays is obtained by shorting together the external resistor terminals of the relay; 3) The maximum time setting within tolerance limits is obtained by using a 1 megohm resistor; 4) Timing values between the minimum and maximum limits are linear with resistance within 10%; 5) Recommend 1/4 W minimum resistor be used.

LOGIC FUNCTION DIAGRAM

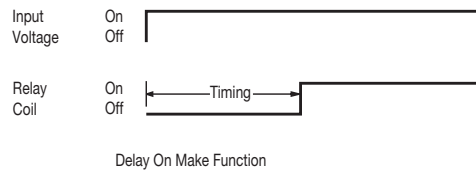

SPECIFICATIONS

TIME DELAY

Adjustment: Knob or external resistor, factory fixed on special order (min. order required)

Range: 100 ms to 5 minutes in 5 ranges

Repeatability: ±.5% at constant temperature and reset time, but not less than 16 ms.

Accuracy: Maximum time +(10%, +20 ms)/-0%; Minimum time -50%/+(0%, +20 ms)

Reset Time: 80 ms max.

INPUT

Operating Voltage: 24, 120 VAC; 12, 24 VDC ±10% (DC models have reverse polarity protection. Unfiltered input voltage to them must be full-wave rectified)

Power Consumption: 3 VA max.

Frequency: 50/60 Hz (AC units)

OUTPUT

Type: Relay contacts, DPDT (2 form C)

Rating: 10 A max. resistive at 240 VAC; 100 mA at 5 VDC min. load current

Life:

Mechanical: 1,000,000 operations

Full Load: 150,000 operations

PROTECTION

Transient Voltage: 12 and 24 V timers are protected by a 1 joule metal oxide varistor; 120 V and 240 V timers are protected by a 5 joule metal oxide varistor.

Dielectric Breakdown: 1500 VAC, RMS min. at 60 Hz between input and outputs and between outputs

MECHANICAL

Termination: Spade (.187" x .020" terminal) type plug-in base

Mounting: Socket mount, part number MSO-00KUP-012, or flange mount

ENVIRONMENTAL

Storage Temperature: -23°C to 70°C

Operating Temperature: -23°C to 55°C

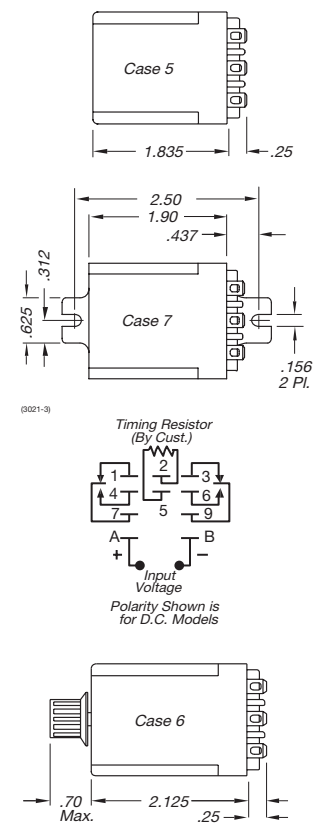

ORDERING INFORMATION

TIME RANGE	12 VDC KNOB ADJUST CASE 6	12 VDC REMOTE POT CASE 5	24 VDC KNOB ADJUST CASE 6	24 VDC REMOTE POT CASE 5
.1 to 10 sec.	K1K-00010-666	K1K-00010-566	K1K-00010-662	—
.3 to 30 sec.	K1K-00030-666	K1K-00030-566	—	—
.6 to 60 sec.	K1K-00060-666	K1K-00060-566	K1K-00060-662	K1F-00060-562
3 to 300 sec.	K1K-00300-666	—	K1K-00300-662	—

TIME RANGE	24 VAC KNOB ADJUST CASE 6	24 VAC REMOTE POT CASE 5	120 VAC KNOB ADJUST CASE 6	120 VAC REMOTE POT CASE 7	120 VAC REMOTE POT CASE 5
.1 to 5 sec.	—	—	—	K1K-00005-761	—
.1 to 10 sec.	K1K-00010-667	K1K-00010-567	K1K-00010-661	—	K1F-00010-561
.3 to 30 sec.	—	—	K1K-00030-661	K1K-00030-761	—
.6 to 60 sec.	—	—	K1K-00060-661	—	K1F-00060-561
3 to 300 sec.	K1K-00300-667	—	K1K-00300-661	—	—

Optional Potentiometer: Part Number ASY-0001M-450

Consult factory for any special requirements not listed in catalog (minimum order requirement may apply).

Delay On Make Z1 Series

FEATURES

- 100% functionally tested
- Digital timing circuit
- Time delays to 5 minutes
- ±1% repeatability
- Fast-on terminals for quick installation
- Low cost, open board construction
- Fiberglass reinforced circuit board
- File #E59090

Operating Logic: Upon application of voltage to the input terminals, the time delay cycle starts. At the end of the preset time delay, the relay coil is energized and the contacts transfer. Reset is accomplished by the removal of input voltage.

LOGIC FUNCTION DIAGRAM

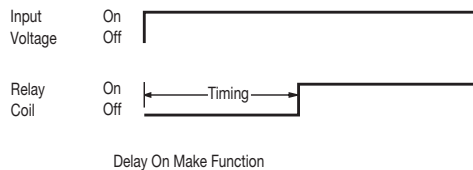

SPECIFICATIONS

TIME DELAY

Adjustment: Trimpot, factory fixed on special order (min. order required)
Range: 100 ms to 5 minutes in 4 ranges (other ranges available on special order)
Repeatability: ±1% at constant temperature
Accuracy: Maximum -0%, +10%; Minimum time +0%, -50%
Reset Time: 50 ms max. (25 ms typical)

INPUT

Operating Voltage: 24, 120 VAC; 24 VDC ±10% (DC models have reverse polarity protection; unfiltered input voltage to them must be full-wave rectified)
Power Consumption: 3 VA max.
Frequency: 50/60 Hz

OUTPUT

Type: Relay contacts, DPDT (2 form C)
Rating: 10 A max. resistive at 240 VAC; 100 mA at 5 VDC min. load current
Life:
 Mechanical: 10,000,000 operations
 Full Load: 500,000 operations

PROTECTION

Transient Voltage: 24 V timers are protected by an 8.8 joule metal oxide varistor; 120 V timers are protected by a 30 joule metal oxide varistor
Dielectric Breakdown: 1500 VAC, RMS min. at 60 Hz between input and outputs and between outputs

MECHANICAL

Termination: .25" x .032" male fast-on terminals
Mounting: .25" standoffs, #6 screw

ENVIRONMENTAL

Storage Temperature: -23°C to 70°C
Operating Temperature: -23°C to 55°C

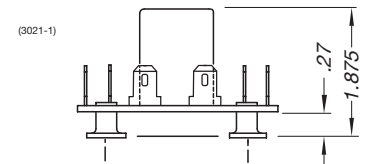
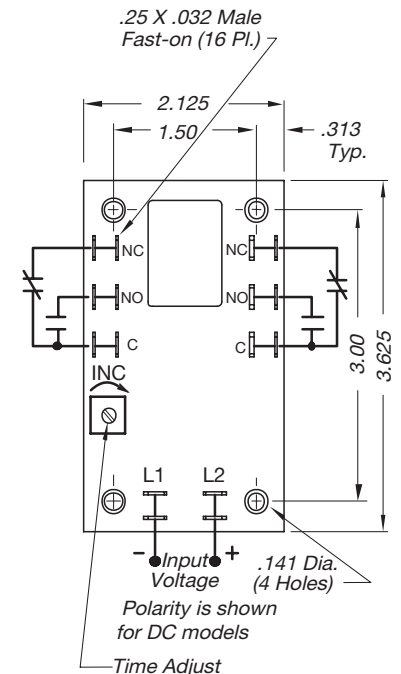
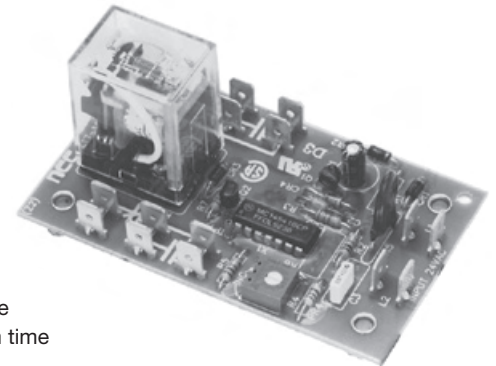

ORDERING INFORMATION

TIME RANGE	24 VAC	120 VAC
.1 to 1 sec.	—	Z1T-00010-061
.6 to 60 sec.	Z1T-00060-067	Z1T-00060-061
1.8 to 180 sec.	Z1T-00180-067	—
3 to 300 sec.	Z1T-00300-067	Z1T-00300-061

Consult factory for any special requirements not listed in catalog (minimum order requirement may apply).

Single Shot T2 Series

FEATURES

- 100% functionally tested
- Digital timing circuit
- Time delays to 1 hour
- ±1% repeatability
- Superior transient protection
- Fiberglass reinforced circuit board
- Internal components supported by heavy-duty chassis
- Reinforced locator pin
- Flame-retardant and solvent-resistant polyester thermoplastic housing
- File #E59090

Operating Logic: Voltage is applied to the timer at all times. Upon a momentary or maintained closure of a normally open isolated start switch, the output relay coil is energized and the time delay starts. At the end of the preset time delay, the relay coil is de-energized and the timer is ready for a new cycle.

Note: 1) Do not apply voltage or ground to the Start switch, 2) Switch leads should be shielded when running close to other wires (Start switch supplied by customer)

LOGIC FUNCTION DIAGRAM

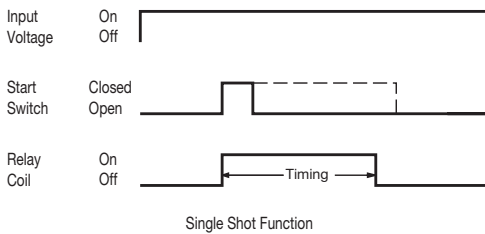

SPECIFICATIONS

TIME DELAY

Adjustment: Knob, factory fixed on special order (min. order required)

Range: 100 ms to 1 hour in 7 ranges

Repeatability: ±1% at constant temperature

Accuracy: Maximum time -0%, +10%; Minimum time +0%, - 50%

Reset Time: 400 ms max.

INPUT

Operating Voltage: 24, 120 VAC; 12, 24 VDC ±10% (DC models have reverse polarity protection; unfiltered input voltage to them must be full-wave rectified)

Start Switch Closure Time: 20 ms min.

Power Consumption: 3 VA max.

Frequency: 50/60 Hz

OUTPUT

Type: Relay contacts, SPDT (1 form C) or DPDT; (2 form C)

Rating: 10 A max. resistive at 240 VAC; 100 mA at 5 VDC min. load current

Life:

Mechanical: 10,000,000 operations

Full Load: 500,000 operations

PROTECTION

Transient Voltage: 12 and 24 V timers are protected by an 8.8 joule metal oxide varistor; 120 V timers are protected by a 30 joule metal oxide varistor

Dielectric Breakdown: 1500 VAC, RMS min. at 60 Hz between input and outputs and between outputs

MECHANICAL

Termination: 8-pin or 11-pin plug

Mounting: Socket mount, 8-pin part number MSO-0008P-012; socket mount, 11-pin part number MSO-0011P-012

ENVIRONMENTAL

Storage Temperature: -23°C to 70°C

Operating Temperature: -23°C to 55°C

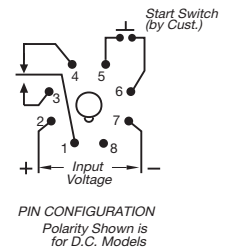
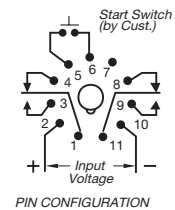
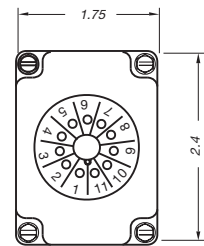
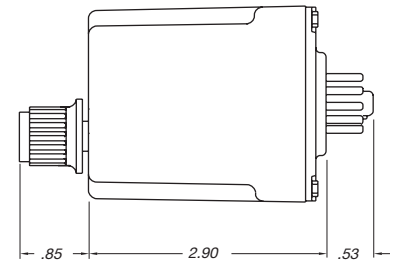

ORDERING INFORMATION

TIME RANGE	12 VDC DPDT RELAY 11-PIN BASE	24 VDC DPDT RELAY 11-PIN BASE	24 VAC DPDT RELAY 11-PIN BASE	120 VAC SPDT RELAY 8-PIN BASE	120 VAC DPDT RELAY 11-PIN BASE
.1 to 10 sec.	T2K-00010-466	T2K-00010-462	T2K-00010-467	T2K-00010-441	T2K-00010-461
.3 to 30 sec.	—	—	—	—	T2K-00030-461
.6 to 60 sec.	T2K-00060-466	T2K-00060-462	T2K-00060-467	T2K-00060-441	T2K-00060-461
1.8 to 180 sec.	—	—	—	—	T2K-00180-461
3 to 300 sec.	—	—	—	—	T2K-00300-461
6 to 600 sec.	—	—	—	—	T2K-00600-461
36 to 3600 sec.	—	—	—	—	T2K-03600-461

Consult factory for any special requirements not listed in catalog (minimum order requirement may apply).

Single Shot Q2T Series

FEATURES

- 100% functionally tested
- Solid state digital timing
- Time delays to 5 hours standard
- 20:1 maximum to minimum timing ratio
- Cost efficient
- Compact size
- Superior transient protection
- Epoxy encapsulated
- Flame-retardant and solvent-resistant polyester thermoplastic housing
- Trimpot on-board with sealed cermet element
-  File #E65038

Operating Logic: Power is applied to the timer at all times. Upon a momentary or maintained closure of a normally open isolated start switch, the output is energized and the time delay starts. At the end of the preset time delay, the output is de-energized and the unit is ready for a new cycle.

Note: 1) Do not apply voltage or ground to the start switch; 2) Switch leads should be shielded when running close to other wires. (Start switch supplied by customer.)

ORDERING INFORMATION

TIME RANGE	120 VAC ±10%
.05 to 1 sec.	Q2T-00001-321
.25 to 5 sec.	Q2T-00005-321
.5 to 10 sec.	Q2T-00010-321
3 to 60 sec.	Q2T-00060-321
15 to 300 sec.	Q2T-00300-321
30 to 600 sec.	Q2T-00600-321
180 to 3600 sec.	Q2T-03600-321
.25 to 5 hrs.	Q2T-18000-321

Trigger time (start switch closure)	20 ms
Reset time	300 ms
Min. load	2 mA
Max. leakage current	200 uA
Voltage drop at 1 A	3.3 V max.
Power consumption	4.3 VA max.
Peak 1 cycle surge	20 A
Protection	30j. MOV

LOGIC FUNCTION DIAGRAM

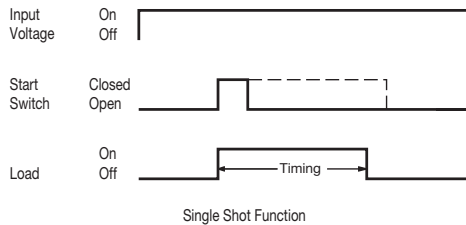

SPECIFICATIONS

TIME DELAY

Adjustment: On-board Trimpot
Range: 50 ms to 5 hours in 8 ranges
Repeatability: ±.5% +8 ms max. (0.25% typical) at constant temperature
Accuracy: Maximum time +10%, -0%; Minimum time -30%, +0%

INPUT

Operating Voltage: 120 VAC ±10%
Frequency: 50/60 Hz

OUTPUT

Type: Solid state, normally open
Rating: 1 A resistive or inductive
Life: 100,000,000 cycles

PROTECTION

Transient Voltage: 30 joule metal oxide varistor
Dielectric Breakdown: 3000 VAC, RMS, terminals to mounting
Insulation Resistance: 100 megohms min. between terminals and case

MECHANICAL

Termination: .25" x .032" male fast-on terminals
Mounting: Surface mount with one #8 screw

ENVIRONMENTAL

Storage Temperature: -40°C to 85°C
Operating Temperature: -40°C to 65°C
Humidity: 95% relative

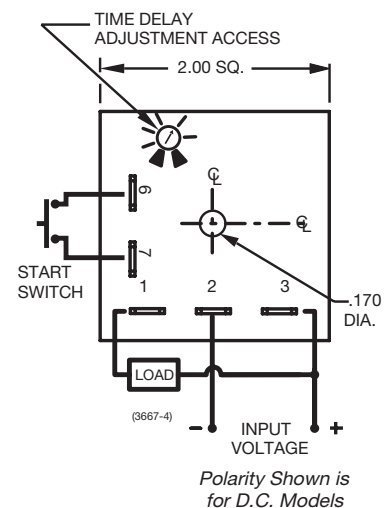
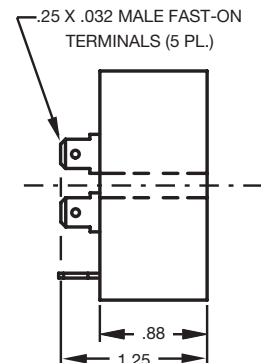

Consult factory for any special requirements not listed in catalog (minimum order requirement may apply).

Single Shot Q2F Series

FEATURES

- 100% functionally tested
- Solid state digital timing
- Time delays to 10 hours standard
- 20:1 maximum to minimum timing ratio
- Low cost
- Compact size
- Superior transient protection
- Flame-retardant and solvent-resistant polyester thermoplastic housing
- File #E65038

Operating Logic: Input voltage is applied to the timer at all times. Upon a momentary or maintained closure of a normally open isolated start switch, the load energizes and the time delay starts. At the end of the pre-set time delay, the load de-energizes and the timer is ready for a new timing cycle. (Start switch supplied by customer)

Note: 1) Remote start switch leads should be shielded when running close to other wires; 2) Remote potentiometer leads should be shielded when running close to other wires; 3) The minimum time setting on external resistor-adjustable time delay relays is obtained by shorting together the external resistor terminals of the relay; 4) The maximum time setting within tolerance limits is obtained by using a 1 megohm resistor; 5) Timing values between the minimum and maximum limits are linear with resistance within 10%; 6) Recommend 1/4 W minimum resistor be used.

ORDERING INFORMATION

TIME RANGE	12 VDC ±10%	24 VAC/DC ±10%	120 VAC ±10%	240 VAC ±10%
.05 to 1 sec.	Q2F-00001-326	Q2F-00001-327	Q2F-00001-321	Q2F-00001-325
.25 to 5 sec.	Q2F-00005-326	Q2F-00005-327	Q2F-00005-321	Q2F-00005-325
.5 to 10 sec.	Q2F-00010-326	Q2F-00010-327	Q2F-00010-321	Q2F-00010-325
3 to 60 sec.	Q2F-00060-326	Q2F-00060-327	Q2F-00060-321	Q2F-00060-325
15 to 300 sec.	Q2F-00300-326	Q2F-00300-327	Q2F-00300-321	—
30 to 600 sec.	Q2F-00600-326	Q2F-00600-327	Q2F-00600-321	Q2F-00600-325
180 to 3600 sec.	Q2F-03600-326	Q2F-03600-327	Q2F-03600-321	—
.25 to 5 hrs.	Q2F-18000-326	Q2F-18000-327	Q2F-18000-321	Q2F-18000-325
.5 to 10 hrs.	Q2F-36000-326	—	Q2F-36000-321	—

Trigger time (start switch closure)	20 ms	20 ms	20 ms	20 ms
Reset time	200 ms	300 ms	300 ms	200 ms
Min. load	5 mA	5 mA	2 mA	2 mA
Max. leakage current	10 uA	10 uA	200 uA	300 uA
Voltage drop at 1 A	2.1 V	3.2 V	3.3 V	3.3 V
Power consumption	2.6 W	3.7 VA max.	4.3 VA max.	5.8 VA max.
Peak 1 cycle surge	4 A	4 A	20 A	20 A
Protection	8.8j. MOV	8.8j. MOV	30j. MOV	30j. MOV

Optional Potentiometer: Part Number ASY-0001M-450

Consult factory for any special requirements not listed in catalog (minimum order requirement may apply).

LOGIC FUNCTION DIAGRAM

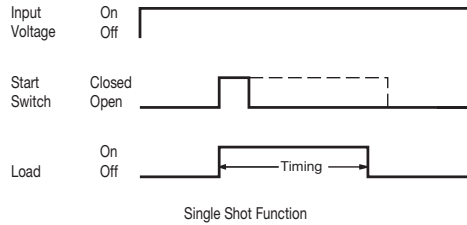

SPECIFICATIONS

TIME DELAY

Adjustment: External resistor factory fixed on special order (min. order requirement)

Range: 50 ms to 10 hours in 9 ranges

Repeatability: ±.5% +8 ms max. (0.25% typical) at constant temperature

Accuracy:

Maximum time ±2% at $R_t = 1$ megohms
Minimum time +0%, -30% at $R_t = 0$ ohm

INPUT

Operating Voltage: 120, 240 VAC; 12 VDC; 24 VAC/DC ±10% (DC models have reverse polarity protection; unfiltered input voltage to them must be full-wave rectified)

Frequency: 50/60 Hz

OUTPUT

Type: Solid state, normally open

Rating: 1 A steady state

Life: 100,000,000 operations

PROTECTION

Transient Voltage: Metal oxide varistor, see ratings below

Dielectric Breakdown: 3000 VAC, RMS, terminals to mounting



Insulation Resistance: 100 megohms min. between terminals and case

MECHANICAL

Termination: .25" x .032" male fast-on terminals

Mounting: Surface mount with one #8 screw

ENVIRONMENTAL

Storage Temperature: -40°C to 85°C

Operating Temperature: -40°C to 65°C

Humidity: 95% relative

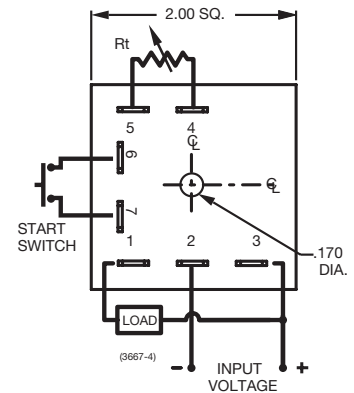
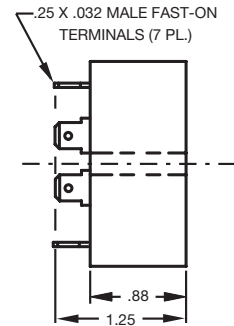

Polarity Shown is for D.C. Models

External Resistance/Time Delay Relationship

1 megohm external resistance is required to obtain the maximum time for all ranges. To determine the actual resistance needed to obtain the required time delay, use the following formula:

$$R_t = \frac{\text{Required} - T_{\text{minimum}}}{T_{\text{maximum}} - T_{\text{minimum}}} \times 1,000,000 \text{ ohms}$$

Note: Due to component tolerances, the actual time obtained will normally be within 5% of desired time.

Single Shot K2 Series

FEATURES

- 100% functionally tested
- Time delays to 10 seconds
- Low cost
- Compact size
- Spade type base
- Wide operating temperature range
- Fiberglass reinforced circuit board
- Polycarbonate, 94V-2 housing material
- File #E59090

Operating Logic: Voltage is applied to the timer at all times. Upon a momentary or maintained closure of a normally open isolated start switch, the output relay coil is energized and the time delay starts. At the end of the preset time delay, the relay coil is de-energized and the timer is ready for a new cycle.

Note: 1) Do not apply voltage or ground to the Start switch;
2) Switch leads should be shielded when running close to other wires (Start switch supplied by customer)

LOGIC FUNCTION DIAGRAM

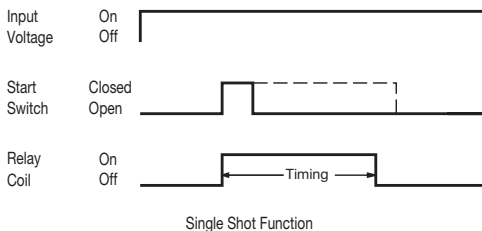

SPECIFICATIONS

TIME DELAY

Adjustment: Knob, factory fixed on special order (min. order required)

Range: 100 ms to 10 sec.

Repeatability: ±3% at constant temperature

Accuracy:

Maximum time +10%/-0%

Minimum time +0%/-50%

Reset Time: 200 ms max.

INPUT

Operating Voltage: 120 V AC ±10%

Start Switch Closure Time: 50 ms min.

Power Consumption: 3 VA max.

Frequency: 50/60 Hz

OUTPUT

Type: Relay contacts, DPDT (2 form C)

Rating: 10 A max. resistive at 240 VAC 100 mA at 5 VDC min. load current

Life:

Mechanical: 10,000,000 operations

Full Load: 500,000 operations

PROTECTION

Transient Voltage: Timers are protected by a 5 joule metal oxide varistor

Dielectric Breakdown: 1500 VAC RMS min. at 60 Hz between input and outputs and between outputs

MECHANICAL

Termination: Spade (.187" x .020" terminal) type plug-in base

Mounting: Socket mount, part number MS0-00KUP-012

ENVIRONMENTAL

Storage Temperature: -23°C to 70°C

Operating Temperature: -23°C to 55°C

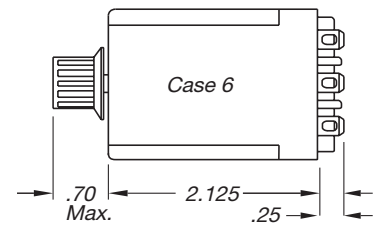

(3021-4)

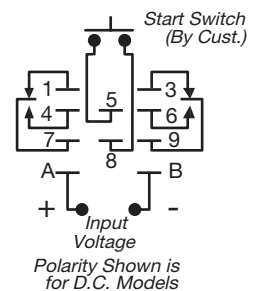
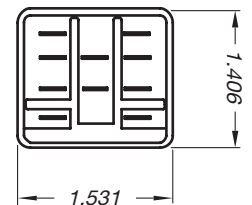

ORDERING INFORMATION

TIME RANGE	120 VAC
.1 to 10 sec.	K2K-00010-661

Consult factory for any special requirements not listed in catalog (minimum order requirement may apply).

Multi-Range Delay On Break (Retriggerable) T3M Series

FEATURES

- 100% functionally tested
- Microprocessor controlled timing circuit
- Five time ranges, user selectable
- Easy 3-digit time cycle setting
- $\pm 0.1\%$ repeatability
- Time cycles from 50 ms to over 16 hours
- Timing light
- Superior transient protection
- Reinforced base locator pin
- Flame-retardant polycarbonate housing
- File #E59090

The T3M Series is a Delay On Break time delay relay featuring easy to program multiple time ranges and digital time selection with extremely high accuracy and repeatability. Programming is accomplished using a 5 position rotary switch to select one of five time ranges. A 3-digit push-button switch selects the amount of time delay required.

Operating Logic: Voltage is continuously applied to the timer. Depending upon the model, either a switch closure or application of control voltage causes the relay coil to be energized and remain so as long as the switch is held closed or control voltage is applied. Opening the switch or removing the control voltage starts the timing cycle. At the end of the preset time delay, the relay coil de-energizes and the timer is ready for a new timing cycle. If the start switch is re-closed or control voltage is re-applied during timing, the timer will reset and will not start timing until the start switch is opened or control voltage is removed. Control leads should be shielded when close to other leads.

LOGIC FUNCTION DIAGRAM

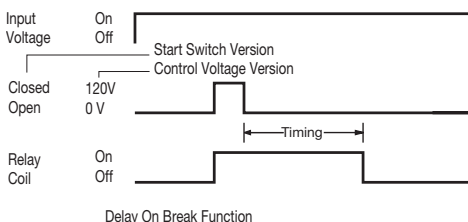

SPECIFICATIONS

TIME DELAY

- Adjustment:** 3 digit push-button switch
- Range:** 50 ms to 999 minutes in 5 ranges
- Repeatability:** $\pm 0.1\%$, ± 0.02 seconds over specified timing range
- Accuracy:** $\pm 1\%$ of set time, plus fixed error of 75 ms max. (10 ms typical)
- Power On Response Time:** 50 ms max.
- Power Off Reset Time:** Requires power interruption of .15 seconds min.
- Start Switch Closure Time:** 20 ms to initiate timing cycle; 50 ms to reset delay during timing cycle

INPUT

- Operating Voltage:** 24, 120 VAC; 12, 24 VDC $\pm 10\%$ (DC models have reverse polarity protection; unfiltered input voltage to them must be full-wave rectified)
- Power Consumption:** 2 VA max.
- Frequency:** 50/60 Hz

OUTPUT

- Type:** Relay contacts, DPDT (2 form C)
- Rating:** 10 A max. resistive at 240 VAC; 100 mA at 5 VDC min. load current
- Life:** Mechanical: 10,000,000 operations
Full Load: 500,000 operations

PROTECTION

- Transient Voltage:** 12 and 24 V timers are protected by an 8.8 joule metal oxide varistor; 120 V timers are protected by a 30 joule metal oxide varistor
- Dielectric Breakdown:** 1500 VAC, RMS min. at 60 Hz between input and outputs and between outputs

Timing Light Logic: Flashing during timing; Full ON after time out

MECHANICAL

- Termination:** 11-pin plug
- Mounting:** Socket mount, part number MSO-0011P-012

ENVIRONMENTAL

- Storage Temperature:** -23°C to 70°C
- Operating Temperature:** -23°C to 55°C
- Humidity:** 95% relative

TIMING

- Selectable Time Ranges:** .05 to 9.99 seconds; .1 to 99.9 seconds; 1 to 999 seconds; .1 to 99.9 minutes; 1 to 999 minutes; (times less than 50 ms are not recommended due to the response time of the mechanical relay)

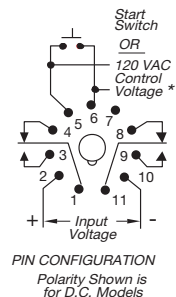
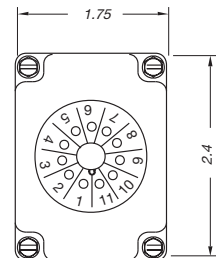
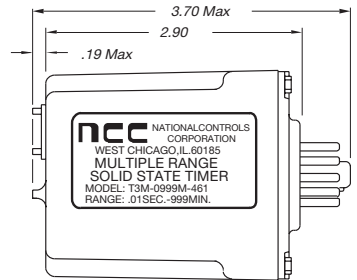
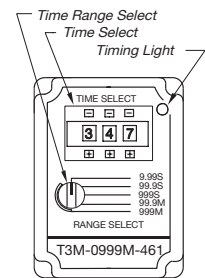



ORDERING INFORMATION

START OF TIMING METHOD	12 VDC	24 VDC	24 VAC	120 VAC
Start Switch	T3M-0999M-466	T3M-0999M-462	T3M-0999M-467	T3M-0999M-461
Control Voltage	—	—	—	T3M-0999M-461V

Delay On Break (Retriggerable) T3 Series

FEATURES

- 100% functionally tested
- Digital timing circuit
- Time delays to 1 hour
- ±1% repeatability
- No false contact transfer when reset during timing
- Superior transient protection
- Fiberglass reinforced circuit board
- Internal components supported by heavy-duty chassis
- Reinforced locator pin
- Flame-retardant polycarbonate housing
-   File #E59090

Operating Logic: Voltage is applied to the timer at all times. Upon a closure of a normally open isolated start switch, the output relay is activated and remains so as long as the switch is kept closed. When the start switch is opened, timing starts. At the end of the preset time delay, the output relay is deactivated and the timer is ready for a new cycle.

Note: 1) Do not apply voltage or ground to the start switch; 2) Switch leads should be shielded when running close to other wires; 3) If the start switch is reclosed during timing, the timer will reset and will not start timing until Start switch is opened.

LOGIC FUNCTION DIAGRAM

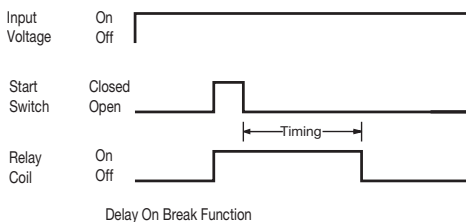

SPECIFICATIONS

TIME DELAY

Adjustment: Knob, factory fixed on special order (min. order required)

Range: 50 ms to 1 hour in 8 ranges

Repeatability: ±1% at constant temperature

Accuracy:

Maximum time -0%, +10%

Minimum time +0%, -50%

Reset Time: 400 ms max.

Start Switch Closure Time: 20 ms to initiate timing; 50 ms to reset delay during timing

INPUT

Operating Voltage: 24, 120 VAC; 12, 24 VDC ±10% (DC models have reverse polarity protection. Unfiltered input voltage to them must be full-wave rectified)

Power Consumption: 3 VA max.

Frequency: 50/60 Hz

OUTPUT

Type: Relay contacts, SPDT (1 form C) or DPDT (2 form C)

Rating: 10 A max. resistive at 240 VAC; 100 mA at 5 VDC min. load current

Life:

Mechanical: 10,000,000 operations

Full Load: 500,000 operations

PROTECTION

Transient Voltage: 12 and 24 V timers are protected by an 8.8 joule metal oxide varistor; 120 V timers are protected by a 30 joule metal oxide varistor

Dielectric Breakdown: 1500 VAC, RMS min. at 60 Hz between input and outputs and between outputs

MECHANICAL

Termination: 8-pin or 11-pin plug

Mounting: Socket mount, 8-pin part number MSO-0008P-012; socket mount, 11-pin part number MSO-0011P-012

ENVIRONMENTAL

Storage Temperature: -23°C to 70°C

Operating Temperature: -23°C to 55°C

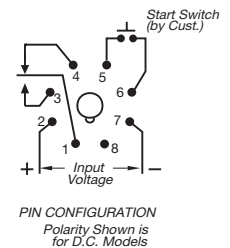
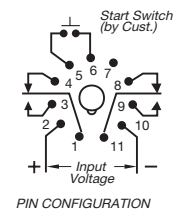
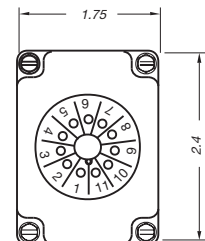
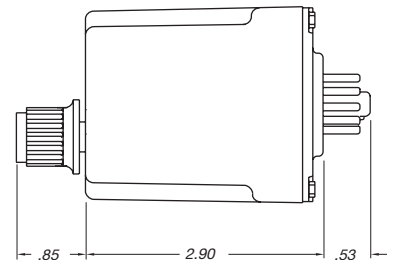

ORDERING INFORMATION

TIME RANGE	12 VDC DPDT RELAY 11-PIN BASE	24 VDC DPDT RELAY 11-PIN BASE	24 VAC DPDT RELAY 11-PIN BASE	120 VAC SPDT RELAY 8-PIN BASE	120 VAC DPDT RELAY 11-PIN BASE
.05 to 5 sec.	—	—	—	—	T3K-00005-461
.1 to 10 sec.	T3K-00010-466	T3K-00010-462	T3K-00010-467	T3K-00010-441	T3K-00010-461
.3 to 30 sec.	—	—	—	—	T3K-00030-461
.6 to 60 sec.	T3K-00060-466	T3K-00060-462	T3K-00060-467	T3K-00060-441	T3K-00060-461
1.8 to 180 sec.	—	—	—	—	T3K-00180-461
3 to 300 sec.	—	—	—	—	T3K-00300-461
6 to 600 sec.	—	—	—	—	T3K-00600-461
36 to 3600 sec.	T3K-03600-466	T3K-03600-462	T3K-03600-467	—	T3K-03600-461

Consult factory for any special requirements not listed in catalog (minimum order requirement may apply).

Delay On Break (Retriggerable) Q3T Series

FEATURES

- 100% functionally tested
- Solid state digital timing
- Time delays to 1 hour standard
- 20:1 maximum to minimum timing ratio
- Cost efficient
- Compact size
- Superior transient protection
- Epoxy encapsulated
- Flame-retardant and solvent-resistant polyester thermoplastic housing
- Trimpot on-board with sealed cermet element
- File #E65038

Operating Logic: Input voltage is applied to the timer at all times. Upon closure of a normally open isolated start switch, the load is energized and remains in this state as long as the switch is kept closed. When the start switch is opened, timing starts. At the end of the preset time delay the output de-energizes and the unit is ready for a new cycle. (Start switch supplied by customer.)

Note: 1) Do not apply voltage or ground to the start switch; 2) Switch leads should be shielded when running close to other wires; 3) If the start switch is re-closed during timing the timer will reset and will not start timing until the start switch is opened.

LOGIC FUNCTION DIAGRAM

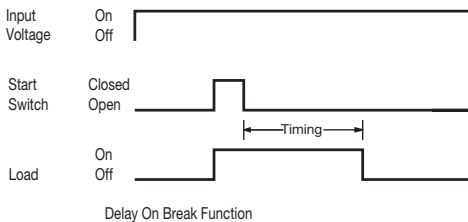

SPECIFICATIONS

TIME DELAY

Adjustment: On-board Trimpot
Range: 50 ms to 1 hour in 7 ranges
Repeatability: $\pm 5\%$ +8 ms max. (0.25% typical) at constant temperature
Accuracy: Maximum time +10%, -0%; Minimum time -30%, +0%
Reset Time: .5 seconds max. by removal of the input voltage

INPUT

Operating Voltage: 120/240 VAC $\pm 10\%$
Frequency: 50/60 Hz

OUTPUT

Type: Solid state normally open
Rating: 1 A resistive or inductive
Life: 100,000,000 cycles

PROTECTION

Transient Voltage: 30 joule metal oxide varistor
Dielectric Breakdown: 3000 VAC, RMS, terminals to mounting
Isolation Resistance: 100 megohms min. between terminals and case

MECHANICAL

Termination: .25" x .032" male fast-on terminals
Mounting: Surface mount with one #8 screw

ENVIRONMENTAL

Storage Temperature: -40°C to 85°C
Operating Temperature: -40°C to 65°C
Humidity: 95% relative

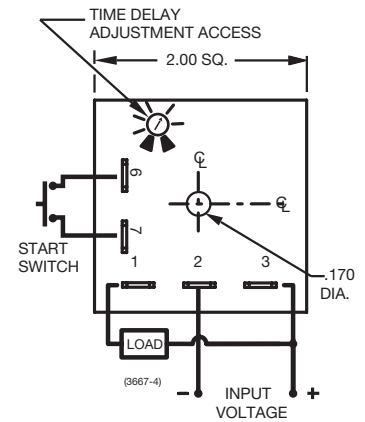
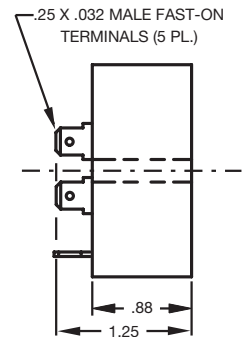

Polarity Shown is for D.C. Models

ORDERING INFORMATION

TIME RANGE	120 VAC $\pm 10\%$	240 VAC $\pm 10\%$
.05 to 1 sec.	Q3T-00001-321	—
.25 to 5 sec.	Q3T-00005-321	—
.5 to 10 sec.	Q3T-00010-321	—
3 to 60 sec.	Q3T-00060-321	—
15 to 300 sec.	Q3T-00300-321	Q3T-00300-325
30 to 600 sec.	Q3T-00600-321	—
180 to 3600 sec.	Q3T-03600-321	—

Trigger time (start switch closure)	20 ms
Reset time	500 ms
Min. load	2 mA
Max. leakage current	200 uA
Voltage drop at 1 A	3.3 V max.
Power consumption	4.3 VA max.
Peak 1 cycle surge	20 A
Protection	30j. MOV

Consult factory for any special requirements not listed in catalog (minimum order requirement may apply).

Delay On Break (Retriggerable) Q3F Series

FEATURES

- 100% functionally tested
- Solid state digital timing
- Time delays to 10 hours standard
- 20:1 maximum to minimum timing ratio
- Low cost
- Compact size
- Superior transient protection
- Flame-retardant and solvent-resistant polyester thermoplastic housing
- File #E65038

Operating Logic: Input voltage is applied to the timer at all times. Upon closure of a normally open isolated start switch, the load energizes and remains energized as long as the switch is closed. When the start switch opens, the timing cycle starts. At the end of the preset time delay, the load de-energizes and the timer is ready for a new timing cycle. (Start switch supplied by customer.)

Note: 1) Do not apply voltage or ground to start switch; 2) remote start switch leads should be shielded when running close to other wires; 3) If the start switch is re-closed during timing, the delay will reset and will not start timing until the start switch is opened; 4) Remote potentiometer leads should be shielded when running close to other wires; 5) The minimum time setting on external resistor-adjustable time delay relays is obtained by shorting together the external resistor terminals of the relay; 6) The maximum time setting within tolerance limits is obtained by using a 1 megohm resistor; 7) Timing values between the minimum and maximum limits are linear with resistance within 10%; 8) Recommend 1/4 W minimum resistor be used.

ORDERING INFORMATION

TIME RANGE	12 VDC ±10%	24 VAC/DC ±10%	120 VAC ±10%	240 VAC ±10%
.05 to 1 sec.	Q3F-00001-326	Q3F-00001-327	Q3F-00001-321	—
.25 to 5 sec.	Q3F-00005-326	—	Q3F-00005-321	Q3F-00005-325
.5 to 10 sec.	Q3F-00010-326	Q3F-00010-327	Q3F-00010-321	Q3F-00010-325
3 to 60 sec.	Q3F-00060-326	Q3F-00060-327	—	—
15 to 300 sec.	—	Q3F-00300-327	Q3F-00300-321	Q3F-00300-325
30 to 600 sec.	—	Q3F-00600-327	—	—
180 to 3600 sec.	Q3F-03600-326	Q3F-03600-327	Q3F-03600-321	Q3F-03600-325
.25 to 5 hrs.	—	Q3F-18000-327	Q3F-18000-321	—
.5 to 10 hrs.	Q3F-36000-326	—	Q3F-36000-321	Q3F-36000-325

Trigger time (start switch closure)	20 ms	20 ms	20 ms	20 ms
Reset time	200 ms	300 ms	200 ms	200 ms
Min. load	5 mA	5 mA	2 mA	2 mA
Max. leakage current	10 uA	10 uA	200 uA	300 uA
Voltage drop at 1 A	2.1 V max.	3.2 V max.	3.3 V max.	3.3 V max.
Power consumption	2.6 W	3.7 VA max.	4.3 VA max.	5.8 VA max.
Peak 1 cycle surge	4 A	4 A	20 A	20 A
Protection	8.8j. MOV	8.8j. MOV	30j. MOV	30j. MOV

Optional Potentiometer: Part Number ASY-0001M-450

LOGIC FUNCTION DIAGRAM

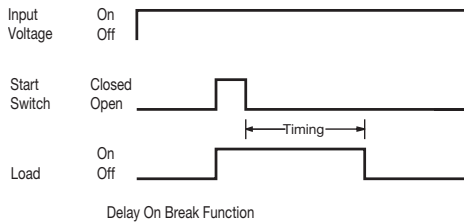

SPECIFICATIONS

TIME DELAY

Adjustment: External resistor, factory fixed on special order (min. order required)
Range: 50 ms to 10 hours in 9 ranges
Repeatability: ±.5% +8 ms max. (0.25% typical) at constant temperature
Accuracy:
 Maximum time ±2% at $R_t = 1$ megohm
 Minimum time +0%-30% at $R_t = 0$ ohm

INPUT

Operating Voltage: 120, 240 VAC; 12 VDC; 24 VAC/DC ±10% (DC models have reverse polarity protection. Unfiltered input voltage to them must be full-wave rectified)
Frequency: 50/60 Hz

OUTPUT

Type: Solid state normally open
Rating: 1 A steady state
Life: 100,000,000 cycles

PROTECTION

Transient Voltage: 30 joule metal oxide varistor, see ratings below
Dielectric Breakdown: 3000 VAC, RMS, terminals to mounting
Isolation Resistance: 100 megohms min. between terminals and case



MECHANICAL

Termination: .25" x .032" male fast-on terminals

Mounting: Surface mount with one #8 screw

ENVIRONMENTAL

Storage Temperature: -40°C to 85°C

Operating Temperature: -40°C to 65°C

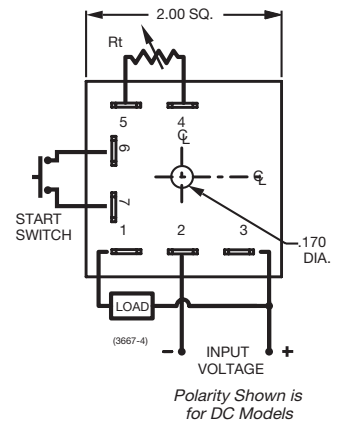
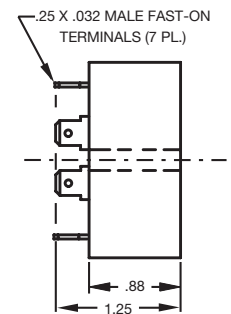

External Resistance/Time Delay Relationship

1 megohm external resistance is required to obtain the maximum time for all ranges. To determine the actual resistance needed to obtain the required time delay, use the following formula:

$$R_t = \frac{\text{Required} - T_{\text{minimum}}}{T_{\text{maximum}} - T_{\text{minimum}}} \times 1,000,000 \text{ ohms}$$

Note: Due to component tolerances, the actual time obtained will normally be within 5% of desired time.

Consult factory for any special requirements not listed in catalog (minimum order requirement may apply).

Delay On Break (Retriggerable) K3 Series

FEATURES

- 100% functionally tested
- No false contact transfer when reset during timing
- Digital timing circuit
- Time delays to 5 minutes
- Low cost
- Compact size
- Spade type base
- Wide operating temperature range
- Fiberglass reinforced circuit board
- Polycarbonate, 94V-2 housing material
- File #E59090

Operating Logic: Input voltage is applied to the timer at all times. Upon a closure of a normally open isolated start switch, the output relay is activated and remains so as long as the switch is kept closed. When the start switch is opened, timing starts. At the end of the preset time delay, the output relay is deactivated and the timer is ready for a new cycle.

Note: 1) Do not apply voltage or ground to the start switch; 2) Switch leads should be shielded when running close to other wires; 3) If the start switch is re-closed during timing, the timer will reset and will not start timing until start switch is opened (Start switch supplied by customer).

LOGIC FUNCTION DIAGRAM

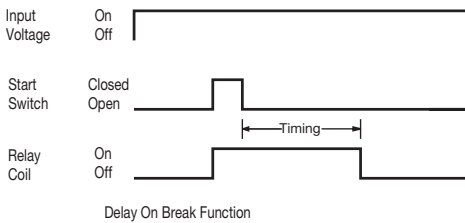

SPECIFICATIONS

TIME DELAY

Adjustment: Knob, factory fixed on special order (min. order required)

Range: 100 ms to 5 min. in 3 ranges

Repeatability: ±3% at constant temperature

Accuracy:

Maximum time: +10%/-0%

Minimum time: -50%/+0%

Reset Time: 150 ms max.

Start Switch Closure Time: 50 ms to initiate timing; 100 ms to reset delay during timing

INPUT

Operating Voltage: 120 VAC ±10%

Power Consumption: 3 VA max.

Frequency: 50/60 Hz

OUTPUT

Type: Relay contacts, DPDT (2 form C)

Rating: 10 A max. resistive at 240 VAC 100 mA at 5 VDC min. load current

Life:

Mechanical: 10,000,000 operations

Full Load: 500,000 operations

PROTECTION

Transient Voltage: 120 V timers are protected by a 5 joule metal oxide varistor

Dielectric Breakdown: 1500 VAC, RMS min. at 60 Hz between input and outputs and between outputs

MECHANICAL

Termination: Spade (.187" x .020" terminal) type plug-in base

Mounting: Socket mount, part number MSO-00KUP-012

ENVIRONMENTAL

Storage Temperature: -23°C to 70°C

Operating Temperature: -23°C to 55°C

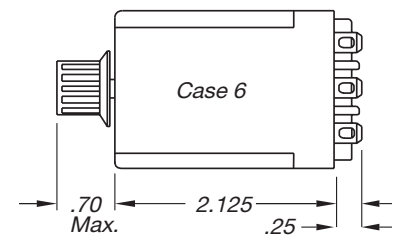

(3021-4)

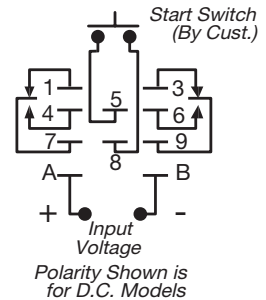
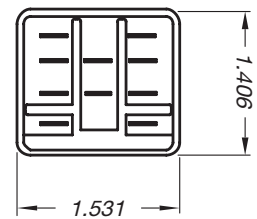

ORDERING INFORMATION

TIME RANGE	120 VAC
.1 to 10 sec.	K3K-00010-661
.6 to 60 sec.	K3K-00060-661
3 to 300 sec.	K3K-00300-661

Consult factory for any special requirements not listed in catalog (minimum order requirement may apply).

Delay On Break (Retriggerable) Z3 Series

FEATURES

- 100% functionally tested
- No false contact transfer when reset during timing
- Digital timing circuit
- Time delays to 5 minutes
- ±1% repeatability
- Superior transient protection
- Fast-on terminals for quick installation
- Low cost, open board construction
- Fiberglass reinforced circuit board
- Trimpot on-board with sealed cermet element
-  File #E59090

Operating Logic: Voltage is applied to the timer at all times. Upon a closure of a normally open isolated start switch, the output relay is activated and remains so as long as the switch is kept closed. When the start switch is opened, timing starts. At the end of the preset time delay, the output relay is deactivated and the timer is ready for a new cycle.

Note: 1) Do not apply voltage or ground to the start switch; 2) Switch leads should be shielded when running close to other wires; 3) If the start switch is re-closed during timing, the timer will reset and will not start timing until start switch is opened (Start switch supplied by customer).

LOGIC FUNCTION DIAGRAM

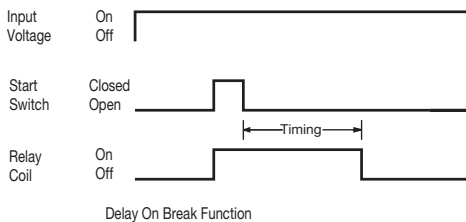

SPECIFICATIONS

TIME DELAY

Adjustment: Trimpot, factory fixed on special order (min. order required)

Range: 3 to 300 sec.

Repeatability: ±1% at constant temperature

Accuracy:

Maximum time -0%, +10%

Minimum time +0%, -50%

Reset Time: 300 ms max.

Start Switch Closure Time: 20 ms to initiate timing; 50 ms to reset delay during timing

INPUT

Operating Voltage: 120 VAC ±10%

Power Consumption: 3 VA max.

Frequency: 50/60 Hz

OUTPUT

Type: Relay contacts, DPDT (2 form C)

Rating: 10 A max. resistive at 240 VAC - 100 mA at 5 VDC min. load current

Life:

Mechanical: 10,000,000 operations

Full Load: 500,000 operations

PROTECTION

Transient Voltage: Timers are protected by a 30 joule metal oxide varistor

Dielectric Breakdown: 1500 VAC, RMS min. at 60 Hz between input and outputs and between outputs

MECHANICAL

Termination: .25" x .032" male fast-on terminals

Mounting: .25" standoffs, #6 screw

ENVIRONMENTAL

Storage Temperature: -23°C to 70°C

Operating Temperature: -23°C to 55°C

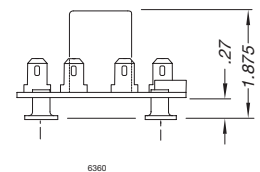
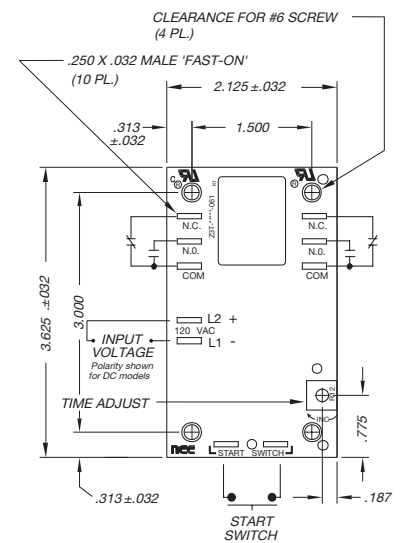
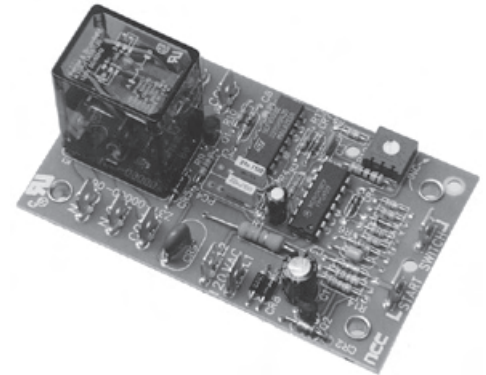



ORDERING INFORMATION

TIME RANGE	120 VAC
3 to 300 sec.	Z3T-00300-061

Consult factory for any special requirements not listed in catalog (minimum order requirement may apply).

Interval S1 Series

FEATURES

- 100% functionally tested
- Digital timing circuit
- Time delays to 1 hour
- ±1% repeatability
- Superior transient protection
- Fiberglass reinforced circuit board
- Internal components supported by heavy-duty chassis
- Reinforced base locator pin
- Flame-retardant polycarbonate housing
-   File #E59090

Operating Logic: Upon application of voltage to the input terminals, the relay coil is activated and the timing cycle starts. At the end of the preset time delay, the relay coil is deactivated. Reset is accomplished by removal of the input voltage.

LOGIC FUNCTION DIAGRAM

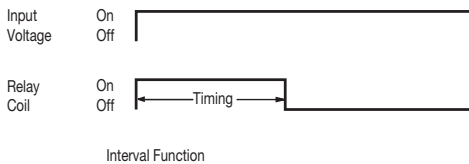

SPECIFICATIONS

TIME DELAY

Adjustment: Knob, factory fixed on special order (min. order required)

Range: 50 ms to 1 hour in 6 ranges

Repeatability: ±1% at constant temperature

Accuracy:

Maximum time -0%, +10%

Minimum time +0%, -50%

Reset Time: 50 ms max.

INPUT

Operating Voltage: 24, 120 VAC; 12, 24 VDC ±10% (DC models have reverse polarity protection; unfiltered input voltage to them must be full-wave rectified)

Power Consumption: 3 VA max.

Frequency: 50/60 Hz

OUTPUT

Type: Relay contacts, DPDT (2 form C)

Rating: 10 A max. resistive at 240 VAC 100 mA at 5 VDC min. load current

Life:

Mechanical: 10,000,000 operations

Full Load: 500,000 operations

PROTECTION

Transient Voltage: 12 and 24 V timers are protected by an 8.8 joule metal oxide varistor; 120 V timers are protected by a 30 joule metal oxide varistor

Dielectric Breakdown: 1500 VAC, RMS min. at 60 Hz between input and outputs and between outputs

MECHANICAL

Termination: 8-pin plug-in base

Mounting: Socket mount, part number MSO-0008P-012

ENVIRONMENTAL

Storage Temperature: -23°C to 70°C

Operating Temperature: -23°C to 55°C

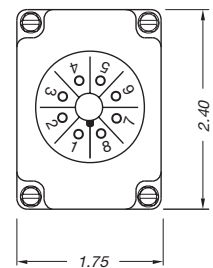
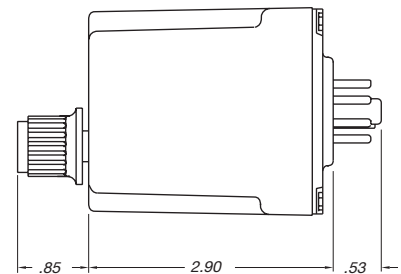

(3012-4)

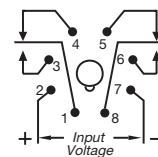

PIN CONFIGURATION
Polarity Shown is for D.C. Models

ORDERING INFORMATION

TIME RANGE	12 VDC	24 VDC	24 VAC	120 VAC
.05 to 5 sec.	—	—	—	S1K-00005-461
.1 to 10 sec.	S1K-00010-466	S1K-00010-462	S1K-00010-467	S1K-00010-461
.6 to 60 sec.	S1K-00060-466	S1K-00060-462	—	S1K-00060-461
1.8 to 180 sec.	—	—	S1K-00180-467	S1K-00180-461
6 to 600 sec.	—	—	—	S1K-00600-461
36 to 3600 sec.	—	—	—	S1K-03600-461

Consult factory for any special requirements not listed in catalog (minimum order requirement may apply).

Interval (Relay Output) Q4T Series

FEATURES

- 100% functionally tested
- Solid state digital timing
- Time delays to 10 hours standard
- 20:1 maximum to minimum timing ratio
- Sealed S.P.D.T output contacts
- Compact size
- Superior transient protection
- Epoxy encapsulated
- Flame-retardant and solvent-resistant polyester thermoplastic housing
- Trimpot on-board with sealed cermet element
-  File #E65038

Operating Logic: Upon application of voltage to the input terminals, the relay is energized, the contacts transfer and the timing cycle starts. At the end of the preset time delay, the relay coil is de-energized and the contacts return to their original state. Reset is accomplished by removing voltage from the input terminals.

LOGIC FUNCTION DIAGRAM

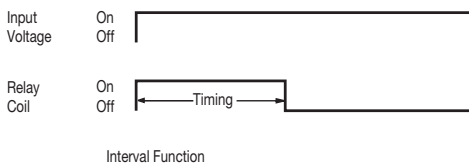

SPECIFICATIONS

TIME DELAY

Adjustment: On-board Trimpot

Range: 50 ms to 10 hours in 8 ranges

Repeatability: ±0.5% max. (0.25% typical) at constant temperature

Accuracy:
Maximum time +10%, -0%
Minimum time -30%, +0%

Reset Time: .25 sec. max., by removal of the input voltage

INPUT

Operating Voltage: 120 VAC ±10%

Power Consumption: 3.5 VA max.

Frequency: 50/60 Hz

OUTPUT

Type: Relay contacts, SPDT (1 form C)

Rating: 8 A max. resistive at 250 VAC and 30 VDC; 100 mA at 5 VDC min. load current

Life:
Mechanical: 10,000,000 cycles;
Electrical: 100,000 min. at full load

PROTECTION

Transient Voltage: 1000 P.I.V. components used

Isolation Resistance: 100 megohms min. between terminals and case

Dielectric Breakdown: 3000 VAC, RMS, terminals to mounting; 1500 VAC, RMS, input to output

MECHANICAL

Termination: .25" x .032" male fast-on terminals

Mounting: Surface mount with one #8 screw

ENVIRONMENTAL

Storage Temperature: -40°C to 70°C

Operating Temperature: -40°C to 70°C

Humidity: 95% relative

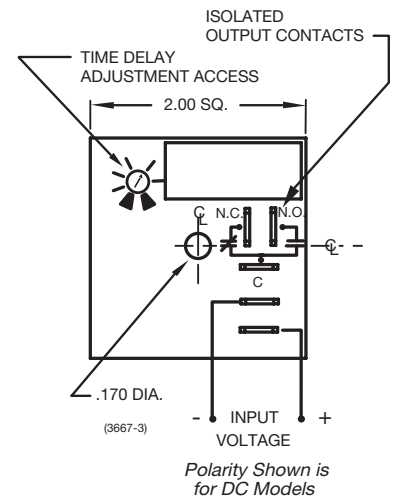
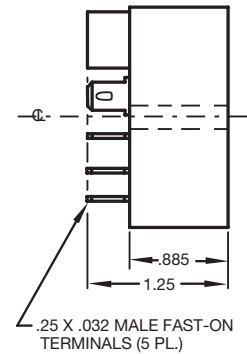

ORDERING INFORMATION

TIME RANGE	120 VAC ±10%
.05 to 1 sec.	Q4T-00001-341
.25 to 5 sec.	Q4T-00005-341
.5 to 10 sec.	Q4T-00010-341
3 to 60 sec.	Q4T-00060-341
15 to 300 sec.	Q4T-00300-341
30 to 600 sec.	Q4T-00600-341
18 to 3600 sec.	Q4T-03600-341
.5 to 10 hrs.	Q4T-36000-341

Consult factory for any special requirements not listed in catalog (minimum order requirement may apply).

Interval Q4F Series

FEATURES

- 100% functionally tested
- Solid state digital timing
- Time delays to 10 hours standard
- 20:1 maximum to minimum timing ratio
- Low cost
- Compact size
- Superior transient protection
- Flame-retardant and solvent-resistant polyester thermoplastic housing
- File #E65038

Operating Logic: Upon application of input voltage the load energizes and the timing cycle starts. At the completion of the preset time delay, the load is de-energized. Reset is accomplished by removal of input voltage.

Note: 1) Remote potentiometer leads should be shielded when running close to other wires; 2) The minimum time setting on external resistor-adjustable time delay relays is obtained by shorting together the external resistor terminals of the relay; 3) The maximum time setting within tolerance limits is obtained by using a 1 megohm resistor; 4) Timing values between the minimum and maximum limits are linear with resistance within 10%; 5) Recommend 1/4 W minimum resistor be used.

LOGIC FUNCTION DIAGRAM

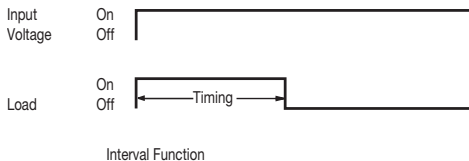

ORDERING INFORMATION

TIME RANGE	12 VDC ±10%	24 VAC/DC ±10%	120 VAC ±10%	240 VAC ±10%
.05 to 1 sec.	Q4F-00001-326	—	Q4F-00001-321	Q4F-00001-325
.25 to 5 sec.	Q4F-00005-326	Q4F-00005-327	Q4F-00005-321	Q4F-00005-325
.5 to 10 sec.	Q4F-00010-326	Q4F-00010-327	Q4F-00010-321	Q4F-00010-325
3 to 60 sec.	Q4F-00060-326	Q4F-00060-327	Q4F-00060-321	—
15 to 300 sec.	Q4F-00300-326	—	Q4F-00300-321	—
30 to 600 sec.	Q4F-00600-326	—	Q4F-00600-321	Q4F-00600-325
180 to 3600 sec.	Q4F-03600-326	Q4F-03600-327	Q4F-03600-321	—
.25 to 5 hrs.	—	Q4F-18000-327	Q4F-18000-321	—
.5 to 10 hrs.	Q4F-36000-326	Q4F-36000-327	Q4F-36000-321	Q4F-36000-325

Trigger time (start switch closure)	75 ms	50 ms	150 ms	150 ms
Reset time	75 ms	50 ms	150 ms	150 ms
Min. load	5 mA	5 mA	2 mA	2 mA
Max. leakage current	20 uA	20 uA	100 uA	100 uA
Voltage drop at 1 A	2.1 V	3.2 V	3.3 V	3.3 V
Power consumption	3.0 W max.	3.0 VA max.	3.0 VA max.	3.0 VA max.
Peak 1 cycle surge	4 A	4 A	20 A	20 A
Protection	rev. V / 8.8j. MOV	8.8j. MOV	30j. MOV	30j. MOV

Optional Potentiometer: Part Number ASY-0001M-450

SPECIFICATIONS

TIME DELAY

Adjustment: External resistor, factory fixed on special order (min. order required)

Range: 50 ms to 10 hours in 9 ranges

Repeatability: ±.5% +8 ms max. (0.25% typical) at constant temperature

Accuracy:

Maximum time ±2% at Rt = 1 megohm
Minimum time +0%-30% at Rt = 0 ohm

INPUT

Operating Voltage: 120, 24 VAC/DC ±10% (DC models have reverse polarity protection; unfiltered input voltage to them must be full-wave rectified)

Frequency: 50/60 Hz

OUTPUT

Type: Solid state, normally open

Rating: 1 A steady state

Life: 100,000,000 operations

PROTECTION

Transient Voltage: Metal oxide varistor, see ratings below

Dielectric Breakdown: 3000 VAC, RMS, terminals to mounting

Insulation Resistance: 100 megohms min. between terminals and case

MECHANICAL

Termination: .25" x .032" male fast-on terminals

Mounting: Surface mount with one #8 screw

ENVIRONMENTAL

Storage Temperature: -40°C to 85°C

Operating Temperature: -40°C to 65°C

Humidity: 95% relative



.25 X .032 MALE FAST-ON TERMINALS (7 PL.)

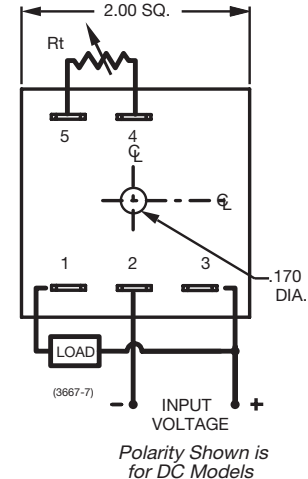
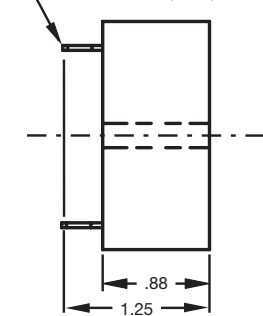

External Resistance/Time Delay Relationship

1 megohm external resistance is required to obtain the maximum time for all ranges. To determine the actual resistance needed to obtain the required time delay, use the following formula:

$$R_t = \frac{\text{Required} - T_{\text{minimum}}}{T_{\text{maximum}} - T_{\text{minimum}}} \times 1,000,000 \text{ ohms}$$

Note: Due to component tolerances, the actual time obtained will normally be within 5% of desired time.

Consult factory for any special requirements not listed in catalog (minimum order requirement may apply).

Interval Z4 Series

FEATURES

- 100% functionally tested
- No false contact transfer when reset during timing
- Digital timing circuit
- Time delays to 5 minutes
- ±1% repeatability
- Fast-on terminals for quick installation
- Low cost, open board construction
- Fiberglass reinforced circuit board
- Trimpot on-board with sealed cermet element
-  File #E59090

Operating Logic: Upon application of voltage to the input terminals, the relay coil is activated and the timing cycle starts. At the end of the preset time delay, the relay coil is deactivated. Reset is accomplished by removal of the input voltage.

LOGIC FUNCTION DIAGRAM

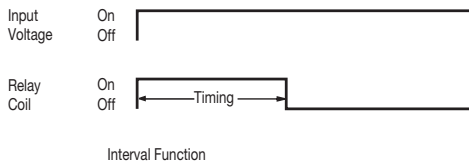

SPECIFICATIONS

TIME DELAY

Adjustment: Trimpot, factory fixed on special order (min. order required)

Range: 3 to 300 sec. (other ranges available on special order)

Repeatability: ±1% at constant temperature

Accuracy:

Maximum time -0%, +10%
Minimum time +0%, -50%

Reset Time: 400 ms max.

INPUT

Operating Voltage: 120 VAC ±10%

Power Consumption: 3 VA max.

Frequency: 50/60 Hz

OUTPUT

Type: Relay contacts, DPDT (2 form C)

Rating: 10 A max. resistive at 240 VAC; 100 mA at 5 VDC min. load current

Life:

Mechanical: 10,000,000 operations
Full Load: 500,000 operations

PROTECTION

Transient Voltage: Timers are protected by a 30 joule metal oxide varistor

Dielectric Breakdown: 1500 VAC, RMS min. at 60 Hz between input and outputs and between outputs

MECHANICAL

Termination: .25" x .032" male fast-on terminals

Mounting: .25" standoffs. #6 screw

ENVIRONMENTAL

Storage Temperature: -23°C to 70°C

Operating Temperature: -23°C to 55°C

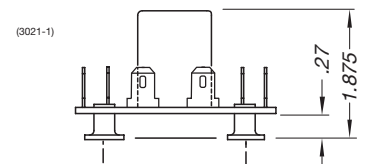
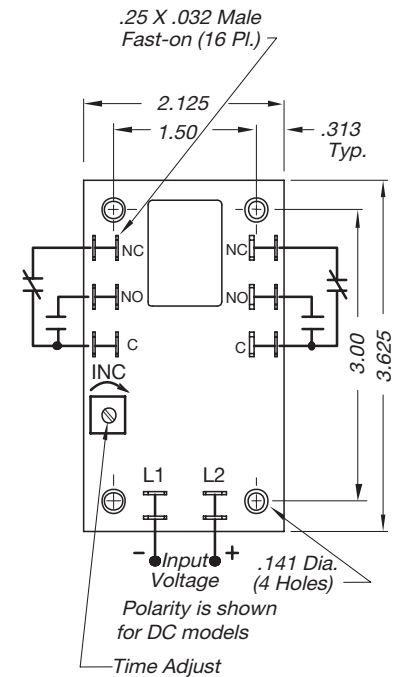
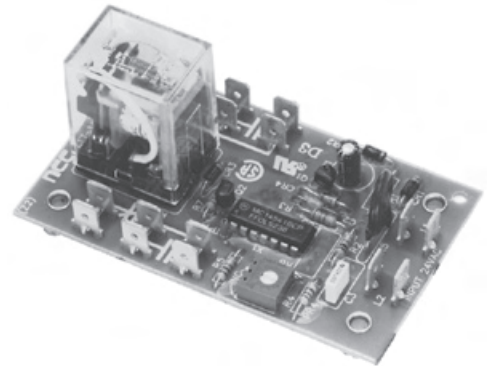



ORDERING INFORMATION

TIME RANGE	120 VAC
3 to 300 sec.	Z4T-00300-061

Consult factory for any special requirements not listed in catalog (minimum order requirement may apply).

Repeat Cycle CKK Series

FEATURES

- 100% functionally tested
- Digital timing circuit
- Time delays to 10 hours
- ±1% repeatability
- Individually adjustable ON and OFF times
- Fiberglass reinforced circuit board
- Internal components supported by heavy-duty chassis
- Reinforced base locator pin
- Polycarbonate flame-retardant housing
-   File #E59090

Operating Logic: Upon application of voltage to the input terminals, the OFF delay is initiated. At the end of the OFF preset time, the relay coil is activated and the ON delay starts. At the end of the ON preset time, the relay coil is deactivated and a new cycle begins. The ON and OFF cycles will continue to alternate until voltage is removed.

LOGIC FUNCTION DIAGRAM

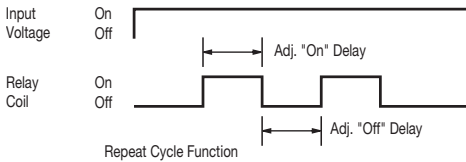

SPECIFICATIONS

TIME DELAY

Adjustment: Knobs, factory fixed on special order (min. order required)

Range: 50 ms to 1 hour in 8 ranges

Repeatability: ±1% at constant temperature

Accuracy:

Maximum time -0%, +10%

Minimum time +0%, -50%

Reset Time: 500 ms max.

INPUT

Operating Voltage: 12, 24 VDC; 24, 120 VAC ±10% (DC models have reverse polarity protection; unfiltered input voltage to them must be full-wave rectified)

Power Consumption: 3 VA max.

Frequency: 50/60 Hz

OUTPUT

Type: Relay DPDT (2 form C)

Rating: 10 A max. resistive at 240 VAC; 100 mA at 5 VDC min. load current

Life:

Mechanical: 10,000,000 operations

Full Load: 500,000 operations

PROTECTION

Transient Voltage: 12 and 24 V timers are protected by an 8.8 joule metal oxide varistor 120 V timers are protected by a 30 joule metal oxide varistor

Dielectric Breakdown: 1500 V RMS min. at 60 Hz between input and outputs and between outputs

MECHANICAL

Termination: 8-pin plug

Mounting: Socket mount, part number MSO-0008P-012

ENVIRONMENTAL

Storage Temperature: -23°C to 70°C

Operating Temperature: -23°C to 55°C

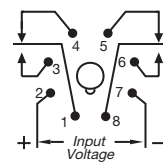
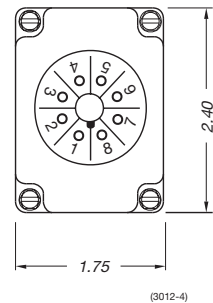
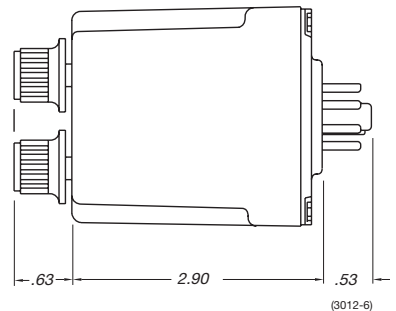

PIN CONFIGURATION
Polarity Shown is
for DC Models

ORDERING INFORMATION

TIME RANGE	12 VDC	24 VDC	24 VAC	120 VAC
.05 to 5 sec.	—	—	—	CKK-00005-461
.1 to 10 sec.	CKK-00010-466	CKK-00010-462	CKK-00010-467	CKK-00010-461
.6 to 60 sec.	CKK-00060-466	CKK-00060-462	CKK-00060-467	CKK-00060-461
1.8 to 180 sec.	CKK-00180-466	CKK-00180-462	CKK-00180-467	CKK-00180-461
3 to 300 sec.	—	—	—	CKK-00300-461
6 to 600 sec.	—	—	—	CKK-00600-461
18 to 1800 sec.	—	—	—	CKK-01800-461
36 to 3600 sec.	—	—	—	CKK-03600-461

Consult factory for any special requirements not listed in catalog (minimum order requirement may apply).

Repeat Cycle Q6F Series

FEATURES

- 100% functionally tested
- Solid state digital timing
- Time delays to 10 hours standard
- 20:1 maximum to minimum timing ratio
- Low cost
- Compact size
- Superior transient protection
- Flame-retardant and solvent-resistant polyester thermoplastic housing
- File #E65038

Operating Logic: Upon application of input voltage, the OFF delay is initiated. At the end of the OFF preset time, the load is activated and the ON delay starts. At the end of the ON preset time, the load is deactivated and a new cycle begins. The ON and OFF cycles will continue to alternate until input voltage is removed.

This timer is available with ON time occurring first logic.

Note: 1) Remote potentiometer leads should be shielded when running close to other wires; 2) The minimum time setting on external resistor-adjustable time delay relays is obtained by shorting together the external resistor terminals of the relay; 3) The maximum time setting within tolerance limits is obtained by using a 1 megohm resistor; 4) Timing values between the minimum and maximum limits are linear with resistance within 10%; 5) Recommend 1/4 W minimum resistor be used.

ORDERING INFORMATION

TIME RANGE	12 VAC/DC ±10%	24 VAC/DC ±10%	120 VAC ±10%	240 VAC ±10%
OFF TIME FIRST LOGIC				
.05 to 1 sec.	Q6F-00001-326	Q6F-00001-327	Q6F-00001-321	Q6F-00001-325
.25 to 5 sec.	Q6F-00005-326	Q6F-00005-327	Q6F-00005-321	Q6F-00005-325
.5 to 10 sec.	Q6F-00010-326	Q6F-00010-327	Q6F-00010-321	Q6F-00010-325
3 to 60 sec.	Q6F-00060-326	Q6F-00060-327	Q6F-00060-321	Q6F-00060-325
15 to 300 sec.	—	Q6F-00300-327	Q6F-00300-321	Q6F-00300-325
30 to 600 sec.	Q6F-00600-326	—	Q6F-00600-321	Q6F-00600-325
180 to 3600 sec.	—	—	Q6F-03600-321	—
.25 to 5 hrs.	Q6F-18000-326	—	—	Q6F-18000-325
.5 to 10 hrs.	—	—	—	Q6F-36000-325
ON TIME FIRST LOGIC				
3 to 60 sec.	Q6F-00060-336	—	Q6F-00060-331	—
30 to 600 sec.	—	—	Q6F-00600-331	—
Trigger time (start switch closure)	500 ms	500 ms	500 ms	500 ms
Reset time	500 ms	500 ms	500 ms	500 ms
Min. load	5 mA	5 mA	2 mA	2 mA
Max. leakage current	100 uA	100 uA	100 uA	100 uA
Voltage drop at 1 A	2.1 V max.	3.2 V max.	3.3 V max.	3.3 V max.
Power consumption	2.6 W max.	3.7 VA max.	4.3 VA max.	5.8 VA max.
Peak 1 cycle surge	4 A	4 A	20 A	20 A
Protection	rev. voltage	8.8j. MOV	30j. MOV	30j. MOV

Optional Potentiometer: Part Number ASY-0001M-450

Consult factory for any special requirements not listed in catalog (minimum order requirement may apply).

LOGIC FUNCTION DIAGRAM

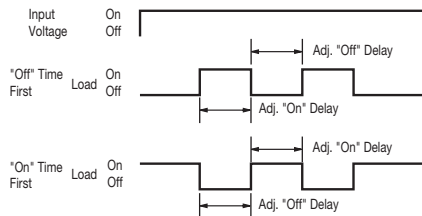

SPECIFICATIONS

TIME DELAY

Adjustment: External resistor, factory fixed on special order (min. order requirement)

Range: 50 ms to 10 hours in 9 ranges

Repeatability: ±.5% +8 ms max. (.25% typical) at constant temperature

Accuracy:

Maximum time ±2% at Rt = 1 megohm
Minimum time +0%, -30% at Rt = 0 ohm

INPUT

Operating Voltage: 120, 240 VAC; 12 VDC; 24 VAC/DC ±10%; (DC models have reverse polarity protection. Unfiltered input voltage to them must be full-wave rectified)

Frequency: 50/60 Hz

MECHANICAL

Termination: .25" x .032" male fast-on terminals

Mounting: Surface mount with one #8 screw

OUTPUT

Type: Solid state, normally open

Rating: 1 A steady state

Life: 100,000,000 operations



PROTECTION

Transient Voltage: Metal oxide varistor see rating below

Dielectric Breakdown: 3000 VAC, RMS, terminals to mounting

Insulation Resistance: 100 megohms min. between terminals and case

ENVIRONMENTAL

Storage Temperature: -40°C to 85°C

Operating Temperature: -40°C to 65°C

Humidity: 95% relative

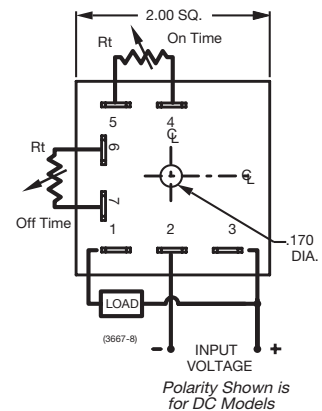
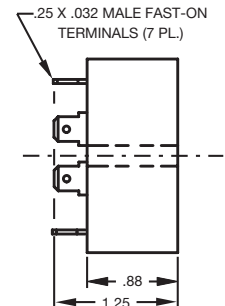

External Resistance/Time Delay Relationship

1 megohm external resistance is required to obtain the maximum time for all ranges. To determine the actual resistance needed to obtain the required time delay, use the following formula:

$$R_t = \frac{\text{Required} - \text{Tminimum}}{\text{Tmaximum} - \text{Tminimum}} \times 1,000,000 \text{ ohms}$$

Note: Due to component tolerances, the actual time obtained will normally be within 5% of desired time.

Flasher Q8F Series

FEATURES

- 100% functionally tested
- Only one timing component required
- Solid state digital timing
- Time delays to 5 minutes standard
- 20:1 maximum to minimum timing ratio
- Low cost
- Compact size
- Superior transient protection
- Flame-retardant and solvent-resistant polyester thermoplastic housing
- File #E65038

Operating Logic: Upon application of voltage to the input terminals, the load is energized for the duration of the preset time delay. At the end of this time delay, the load is de-energized for the duration of the pre-set time delay. The load is then energized again and the timer continues to repeat this on-off cycle until input voltage is removed. Both on and off times are the same and are determined by Rt.

Note: 1) Rt and terminals 4 and 5 are used for external time adjustment; 2) Remote potentiometer leads should be shielded when running close to other wires; 3) The minimum time setting on external resistor-adjustable time delay relays is obtained by shorting together the external resistor terminals of the relay; 4) The maximum time setting within tolerance limits is obtained by using a 1 megohm resistor; 5) Timing values between the minimum and maximum limits are linear with resistance within 10%; 6) Recommend 1/4 W minimum resistor be used.

ORDERING INFORMATION

TIME RANGE	120 VAC ±10%
.05 to 1 sec.	Q8F-00001-321
.25 to 5 sec.	Q8F-00005-321
.5 to 10 sec.	Q8F-00010-321
3 to 60 sec.	Q8F-00060-321
15 to 300 sec.	Q8F-00300-321

Trigger time (start switch closure)	500 ms
Reset time	500 ms
Min. load	2 mA
Max. leakage current	100 uA
Voltage drop at 1 A	3.3 V
Power consumption	4.3 VA max.
Peak 1 cycle surge	20 A
Protection	30j. MOV

Optional Potentiometer: Part Number ASY-0001M-450

LOGIC FUNCTION DIAGRAM

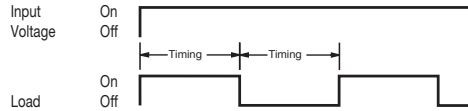

SPECIFICATIONS

TIME DELAY

Adjustment: External resistor, factory fixed on special order (min. order requirement)

Range: 50 ms to 5 minutes in 5 ranges

Repeatability: ±.5% +8 ms max. (0.25% typical) at constant temperature

Accuracy:

Maximum time ±2% at Rt = 1 megohm
Minimum time +0%, -30% at Rt = 0 ohm

INPUT

Operating Voltage: 120 VAC ±10%

Frequency: 50/60 Hz

OUTPUT

Type: Solid state, normally open

Rating: 1 A steady state

Life: 100,000,000 operations

PROTECTION

Transient Voltage: Metal oxide varistor (see rating below)

Dielectric Breakdown: 3000 VAC, RMS, terminals to mounting

Insulation Resistance: 100 megohms min. between terminals and case

MECHANICAL

Termination: .25" x .032" male fast-on terminals

Mounting: Surface mount with one #8 screw

ENVIRONMENTAL

Storage Temperature: -40°C to 85°C

Operating Temperature: -40°C to 65°C

Humidity: 95% relative



-.25 X .032 MALE FAST-ON TERMINALS (5 PL.)

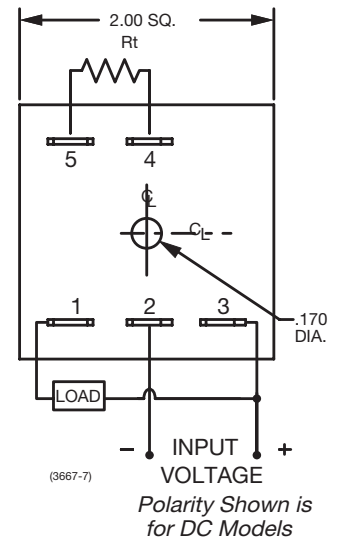
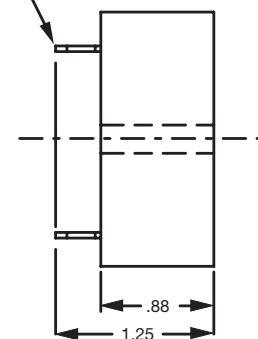

External Resistance/Time Delay Relationship

1 megohm external resistance is required to obtain the maximum time for all ranges. To determine the actual resistance needed to obtain the required time delay, use the following formula:

$$R_t = \frac{\text{Required} - T_{\text{minimum}}}{T_{\text{maximum}} - T_{\text{minimum}}} \times 1,000,000 \text{ ohms}$$

Note: Due to component tolerances, the actual time obtained will normally be within 5% of desired time.

Consult factory for any special requirements not listed in catalog (minimum order requirement may apply).

Repeat Cycle Z6 Series

FEATURES

- 100% functionally tested
- Digital timing circuit
- Time delays to 10 seconds
- $\pm 1\%$ repeatability
- Individually adjustable ON and OFF times
- Components protected by conformal coating
- Low cost, open board construction
- Superior transient protection
- Fiberglass reinforced circuit board
- Trimpot on-board with sealed cermet element
-  File #E59090

Operating Logic: Upon application of voltage to the input terminals, the OFF delay is initiated. At the end of the OFF preset time, the relay coil is activated and the ON delay starts. At the end of the ON preset time, the relay coil is deactivated and a new cycle begins. The ON and OFF cycles will continue to alternate until voltage is removed.

LOGIC FUNCTION DIAGRAM

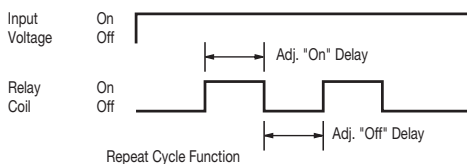

SPECIFICATIONS

TIME DELAY

Adjustment: Trimpot, factory fixed on special order (min. order required)

Range: .1 to 10 sec.

Repeatability: $\pm 1\%$ at constant temperature

Accuracy:

Maximum time -0%, +10%

Minimum time +0%, -50%

Reset Time: 500 ms max.

INPUT

Operating Voltage: 120 VAC $\pm 10\%$

Power Consumption: 3 VA max.

Frequency: 50/60 Hz

OUTPUT

Type: Relay DPDT (2 form C)

Rating: 10 A max. resistive at 240 VAC; 100 mA at 5 VDC min. load current

Life:

Mechanical: 10,000,000 operations

Full Load: 500,000 operations

PROTECTION

Transient Voltage: Timers are protected by a 30 joule metal oxide varistor

Dielectric Breakdown: 1500 V RMS min. at 60 Hz between input and outputs and between outputs

MECHANICAL

Termination: .25" x .032" male fast-on terminals

Mounting: .25" standoffs, #6 screw

ENVIRONMENTAL

Storage Temperature: -23°C to 70°C

Operating Temperature: -23°C to 55°C

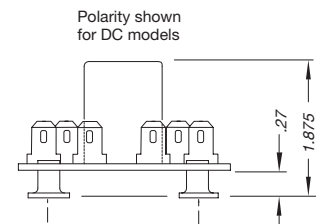
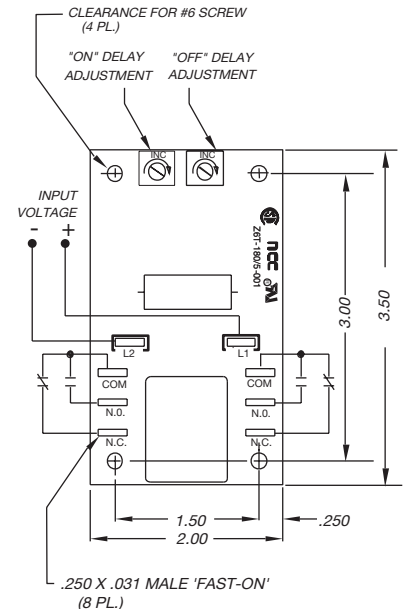
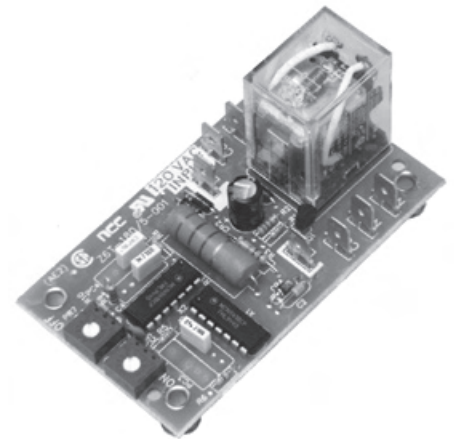

3310/12/92

ORDERING INFORMATION

TIME RANGE	120 VAC
.1 to 10 sec.	Z6T-00010-061

Consult factory for any special requirements not listed in catalog (minimum order requirement may apply).

Universal Voltage Input Buffer

ASY-INPUT-BUFR

FEATURES

- Universal control voltage range: 12 to 240 VAC/DC
- Controls all NCC timers requiring start switch input
- No need for isolated start switch contacts
- Easy interface to programmable logic controllers
- Completely solid state, no moving parts to wear out
- Circuitry completely encapsulated
- Low cost
- Compact size
- Superior transient protection
- Flame-retardant and solvent-resistant polyester thermoplastic housing
-  File #E164906

The universal input buffer will take any voltage from 10.6 to 265 VAC/DC and actuate any NCC timer requiring a start switch to initiate a timing cycle.

Operating Logic: Upon application of input voltage, the output becomes an effective contact closure (within 50 ms). Upon removal of input voltage, the output becomes an effective open circuit (within 50 ms).

LOGIC FUNCTION DIAGRAM

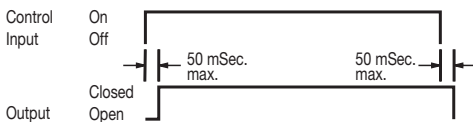

SPECIFICATIONS

INPUT

AC: 10.6 to 265 VAC 50/60 Hz, 5 mA max.

DC: 10.6 to 265 VDC 5 mA max.

Input-Output Delay: 50 ms max.

OUTPUT

Effective contact closure for NCC timers:

Closure: VAC = 9 to 265, 50/60 Hz (6 mA max.)

Closure: VDC = 9 to 265, (6 mA max.)

Voltage drop across output: 2.2 VAC/VDC max. at I=6 ma

Output leakage: At $V_{in} = 0$ VDC and $V_{out} = 265$ VDC, leakage is 25 μ A DC max.

PROTECTION

Transient Voltage: 30 joule metal oxide varistor

Dielectric breakdown: 3000 Vrms terminal to mounting; 1500 Vrms input to output

Insulation resistance: 100 megohms min. between terminals and case

MECHANICAL

Termination: .25" x .032" male fast-on terminals

Mounting: Surface mount with one #8 screw

ENVIRONMENTAL

Storage temperature: -40°C to 85°C

Operating temperature: -40°C to 65°C

Humidity: 95% relative max.

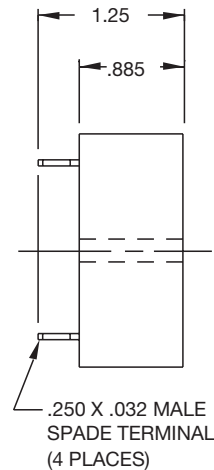

TO NCC
TIMER-TRIGGER
INPUTS

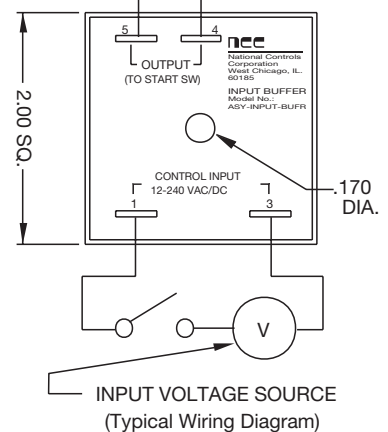

ORDERING INFORMATION



INPUT VOLTAGE RANGE	PART NUMBER
12 to 240 VAC/DC	ASY-INPUT-BUFR

Consult factory for any special requirements not listed in catalog (minimum order requirement may apply).

Fan and Light Control

Model T1517

FEATURES

- One switch controls fan and light
- Digital timing circuit
- Saves energy by automatically turning exhaust fan off
- Adjustable fan turn off time
- Fits single switch outlet box
- Simple wire nut hook-up
- Cover plate and hardware provided
-   File #E95644

Operating Logic: Voltage is applied to the unit at all times via the black and white wires. When the switch is placed in the ON position, power is applied to the lamp and fan output. When the switch is placed in the TIMED position, the power is removed from the lamp output and the fan output stays on for the preset delay time. After the delay time the power is removed from the fan output.

Should the switch be placed in the ON position during the delay time, the timer will be reset and both outputs will be ON as defined above.

Should power be interrupted, when in the TIMED position, the timer will be reset and when power is re-applied the fan output will be ON for the preset delay time after the power is re-applied.

LOGIC FUNCTION DIAGRAM

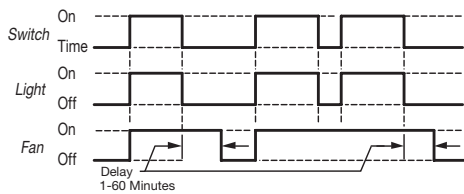

SPECIFICATIONS

TIME DELAY

Adjustment: On-board Trimpot

Range: 1 to 60 minutes

Repeatability: ±0.5% +8ms max.

Accuracy:

Maximum time -0%, +10%

Minimum time -30%, +0%

INPUT

Operating Voltage: 120 VAC ±10%

Power Consumption: 3.5 VA max. at 120 VAC (exclusive of loads)

Frequency: 50/60 Hz

OUTPUT

A-Lamp Load (Switch): 500 W at 120 VAC max. (blue wire)

B-Fan Load (Switch and Relay Contact): 1/3 hp, 10 A (resistive) at 120 VAC max. (red wire)

Life: 100,000 cycles at full load

MECHANICAL

Mounting: Fits single switch outlet box

Electrical: Simple wire nut hook-up

Switch color: Black

ENVIRONMENTAL

Storage Temperature: -40°C to 70°C

Operating Temperature: -40°C to 55°C

Humidity: 95% relative

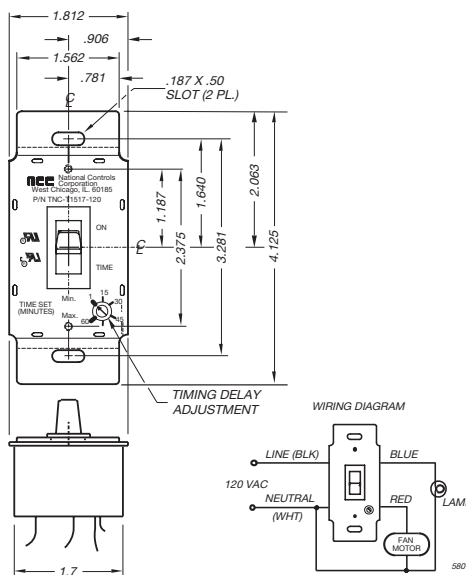

ALL 4 WIRES ARE 18 AWG,
U.L. STYLE 1015, .031 INSULATION

LENGTH MEASURED
FROM THE COVER: 5.5" ± 1.0",
.5" ± .125" STRIP AND TIN TYP.

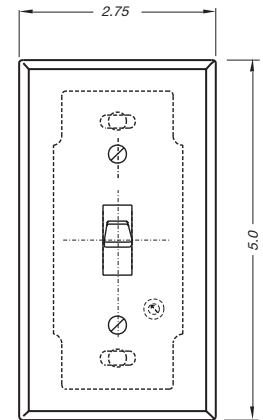
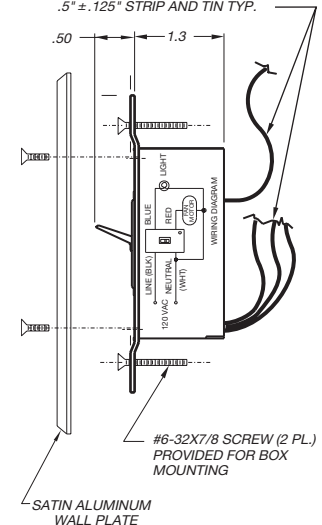

WALL PLATE
(ATTACH AFTER INSTALLATION OF UNIT)

ORDERING INFORMATION

INPUT VOLTAGE	ADJ. OFF DELAY	SWITCH COLOR	PART NUMBER
120 VAC	1 to 60 min.	BLACK	TNC-T1517-120
120 VAC	1 to 60 min.	WHITE	TNC-T1517-120W

Consult factory for any special requirements not listed in catalog (minimum order requirement may apply).

Note: The following hardware is supplied with this product: 2 screws for unit / wall mounting; satin aluminum wall plate with 2 screws; 4 wire connectors (screws and wire connectors packed in plastic bag)

1-34 **TIMER ACCESSORIES**

Potentiometer

NCC remote mounting potentiometers have 24" wire leads, dust protection, 1/4" shaft (no knob) and are calibrated to provide constant timing. These are suitable for mounting through a panel and can be used with a dial and knob.

A locking bushing is used in place of knob to secure setting. Not for use on K or CKK Series timers.

ORDERING INFORMATION

1 Megohm remote potentiometer	ASY-0001M-450
Locking bushing	MLO-K1701-011

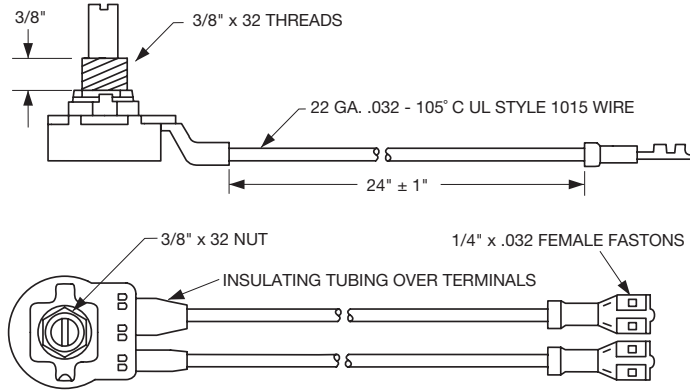

Dial Plate

Range 1 to 100% Dial Plate is shown, others shown in chart are typical.

ORDERING INFORMATION

Dial Plate - Range: 1 to 100%	MDP-0100%-011
Dial Plate - Range: .05 to 2 sec.	MDP-00002-011
Dial Plate - Range: .05 to 5 sec.	MDP-00005-011
Dial Plate - Range: .1 to 10 sec.	MDP-00010-011
Dial Plate - Range: .3 to 30 sec.	MDP-00030-011
Dial Plate - Range: .6 to 60 sec.	MDP-00060-011
Dial Plate - Range: 1.2 to 120 sec.	MDP-00120-011
Dial Plate - Range: 1.8 to 180 sec.	MDP-00180-011
Dial Plate - Range: 3 to 300 sec.	MDP-00300-011
Knob: 1" skirt, 1/4" hole, brass insert	MKN-TK191-011

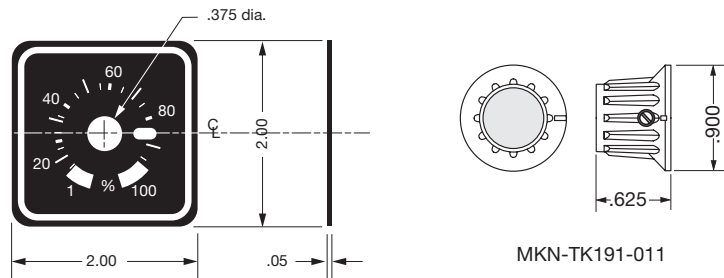

Hold-down Straps

A locking bushing is used in place of knob to secure setting. Used on all plug in timers with knobs except K and CKK Series.

ORDERING INFORMATION

Hold-down strap for K Series timers	ASY-STRAP-5.75L
Hold-down strap for T, S, A, and CKK timers	ASY-STRAP-7.00L
Locking bushing	MLO-010MM-.75

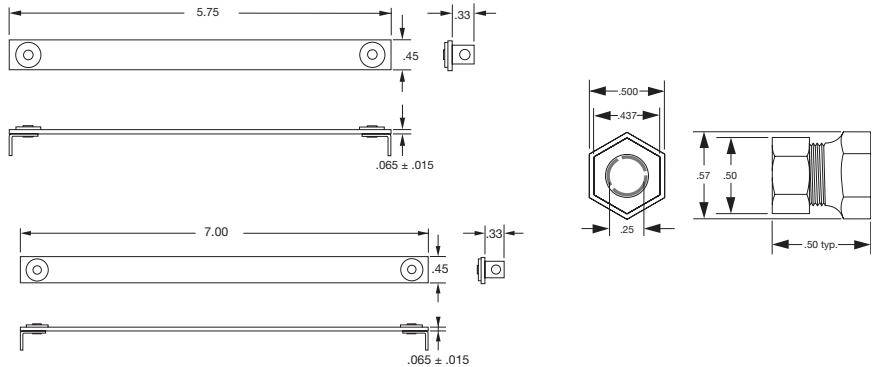

Mounting Bracket

ORDERING INFORMATION

Mounting bracket for 1/16 DIN enclosure	MBK-1/16D-011
---	---------------

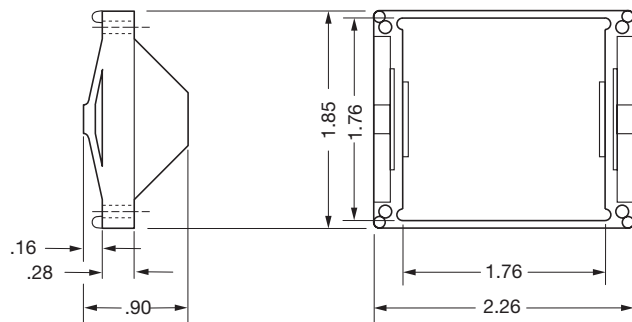

Sockets

ORDERING INFORMATION

8-pin circular socket, DIN rail mountable	MSO-0008P-012
---	---------------

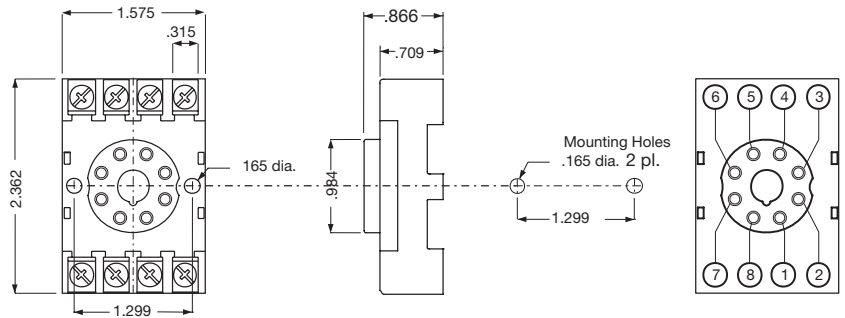

ORDERING INFORMATION

11-pin circular socket, DIN rail mountable	MSO-0011P-012
--	---------------

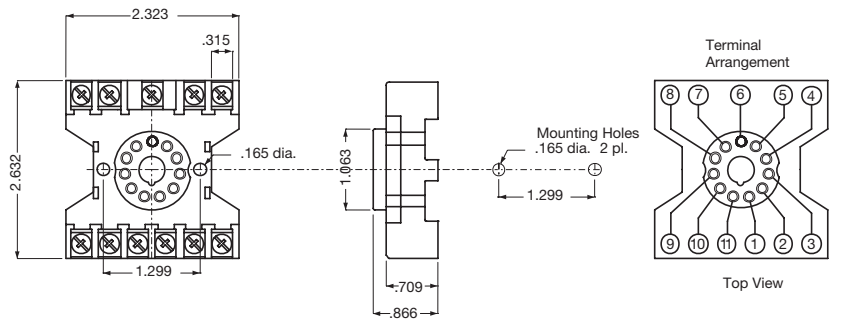

ORDERING INFORMATION

11-pin circular socket for DIN panel mount	MSO-0011P-013
--	---------------

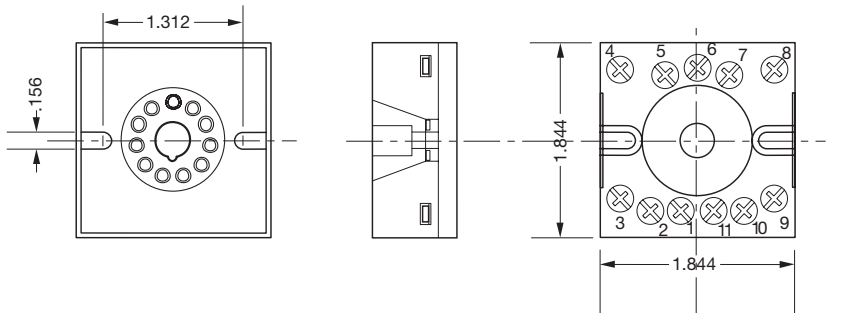

ORDERING INFORMATION

11-pin spade socket, DIN rail mountable	MSO-00KUP-012
---	---------------

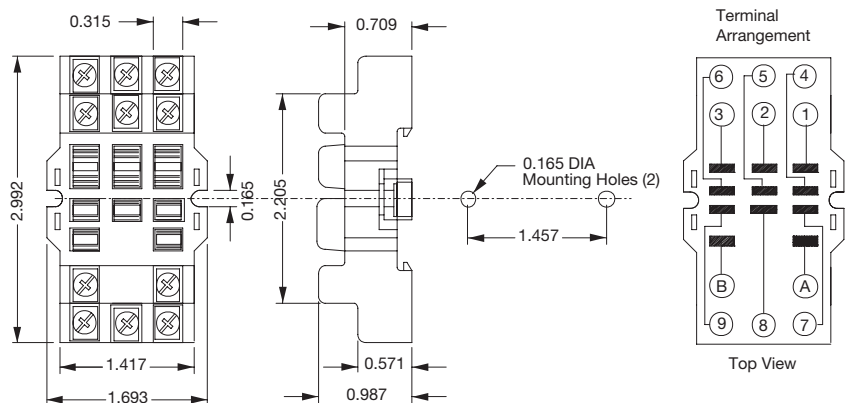

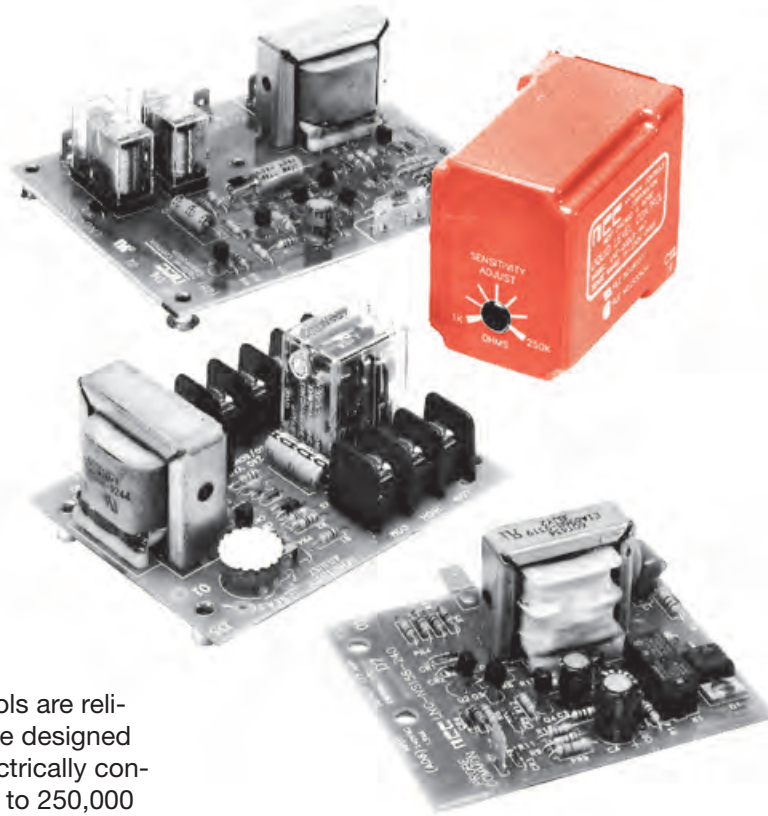

AMETEK NCC Liquid Level Controls are reliable and accurate controls that are designed to detect and control levels of electrically conductive liquids within a range of 0 to 250,000 ohms. These resistance sensor controls provide users with the ability to maintain fluid levels in a variety of sophisticated equipment.

AMETEK NCC has been designing and manufacturing liquid level controls for more than 25 years, producing controls that exceed user standards and expectations for long-life and reliability.

Standard logic functions include Pump-Up and Pump-Down models. Different model features include Dual Probe Resistance Sensors, Low Water Detect Resistance Sensors, Pump-Up Logic with Time Delayed Output, Pump-Up Logic with Heater Burn Out Protection, Dual Probe/Dual Logic Resistance Sensors and Single Probe Sensors.

In addition, AMETEK NCC offers impressive factory back-up support. Our parts inventory and product availability is unsurpassed. With over 250 stocking distributor outlets, serious downtime problems can virtually be eliminated. Technical assistance for design and engineering help is readily available through our **toll free number: 800-323-2593**.

Common Applications:

- *Low Level Pump Controls*
- *Metering Systems*
- *Conveyor Motor Controls*
- *Milk Receiver Pump Controls*
- *Industrial Wastes Pump Controls*
- *Low Water Cutoff and Alarms*
- *Steam Boilers*
- *Foam/Liquid Interface Indication*
- *Deep Well Pump Low Level Cutoff*
- *Water Tank Control*
- *Solenoid Valve Control*
- *Motorized Valve Control*
- *Food Processing Control*
- *Bilge Pump Control*
- *Chemical Batching*

Resistance Sensors (Single Probe)

05SLA and 05SLB Series

FEATURES

- Solid state sensing circuitry
- Single probe level detection
- User adjustable sensing resistance
- Rugged octal plug-in housing
- Heavy duty internal construction
- 100% functionally tested
- File #E61377

These controls utilize a single probe input for maintaining a level of liquid. A built-in time delay prevents rapid cycling. They are packaged in a standard octal plug-in housing. The probe and sensing circuit are isolated from line voltage via a transformer. The probe is driven with an AC signal to prevent plating. The output is an electro-mechanical relay rated at 10 A.

Operating Logic: In the Model 05SLA (Pump Down) the output relay is deactivated as long as no liquid is in contact with the probe. As the liquid makes contact with the probe, a time delay is initiated. At the end of the time delay, the output relay is activated until the liquid breaks contact with the probe.

In the Model 05SLB (Pump Up) the output relay is deactivated as long as the liquid is in contact with the probe. As the liquid drops away from the probe, a time delay is initiated. At the end of the time delay, the output relay is activated until the liquid touches the probe again.

If the tank is non-conductive, a second (common) probe must be installed at a level where it will always be submerged.

SPECIFICATIONS

CONTROL TYPE

On/Off Resistance Sensing: Probe resistance above set point activates output relay after a fixed time delay

Time Delay: 5 sec. $\pm 10\%$, other delay times available

Sensing Voltage: 18 VAC, max. RMS

Sensing Current: 2.0 mA, max. RMS

Sensitivity Adjustment: 1K to 250 K ohms $\pm 10\%$ factory set at 100 K ohms $\pm 10\%$

INPUT

Operating Voltage: 24, 120 or 230 VAC $\pm 10\%$

Power Consumption: 1.2 VA max.

Frequency: 50/60 Hz

OUTPUT

Type: Relay contacts, SPDT (1 form C)

Rating: 10 A resistive at 120, 240 VAC; 100 mA at 5 VDC minimum load current

Life:

Mechanical: 5,000,000 cycles

Electrical: 100,000 min. at full load

PROTECTION

Isolation: 1500 VAC between probe and other terminals

MECHANICAL

Terminations: 8-pin octal plug

Mounting: Socket mount, part number MSO-0008P-012

ENVIRONMENTAL

Operating Temperature: -23°C to 55°C

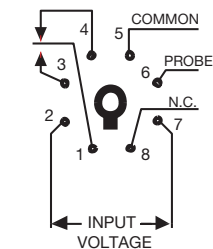
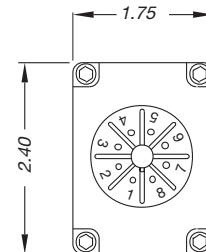
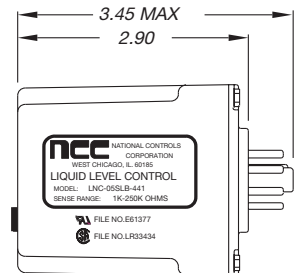
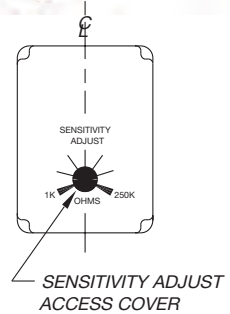

PIN CONFIGURATION

DWG 4787/9/93

ORDERING INFORMATION

LOGIC TYPE	INPUT VOLTAGE	PART NUMBER
05SLA - Pump Down	24 VAC	—
05SLA - Pump Down	120 VAC	LNC-05SLA-441
05SLA - Pump Down	230 VAC	—
05SLB - Pump Up	24 VAC	LNC-05SLB-447
05SLB - Pump Up	120 VAC	LNC-05SLB-441
05SLB - Pump Up	230 VAC	LNC-05SLB-445



ACCESSORY	PART NUMBER
Probe Holder with Ground	LLH-11383-010
Probe, 6" Long, 1/4" Dia., S.S.	LLP-06.00-OSS
Probe, 12" Long, 1/4" Dia., S.S.	LLP-12.00-OSS
Probe, 24" Long, 1/4" Dia., S.S.	LLP-24.00-OSS
Probe Assembly, Plastic Body	LLP-001/2-011
Octal Socket, Back Panel Mount	MSO-0008P-012
Hold Down Strap for Control	ASY-STRAP-7.00L

Consult factory for any special requirements not listed in catalog (minimum order requirement may apply).

Resistance Sensors (Dual Probe)

DLA and DLB Series

FEATURES

- Solid state sensing circuitry
- Dual probe level detection
- User adjustable sensing resistance
- Rugged octal plug-in housing
- Heavy duty internal construction
-   File #E61377

This family of Level Controls provides high and low level sensing with Pump Up or Pump Down capabilities. They are packaged in a standard octal plug-in housing. The probe and sensing circuit are isolated from line voltage via a transformer. The probe is driven with an AC signal to prevent plating. The output is an electro-mechanical relay rated at 10 A.

Operating Logic: In the Model DLA (Pump Down) the output relay is activated when the upper probe detects the presence of liquid and it remains activated until the lower probe detects the absence of liquid.

In the Model DLB (Pump Up) the output relay is activated when the lower probe detects the absence of liquid and it remains activated until the upper probe detects the liquid.

If the tank is non-conductive, a third (common) probe must be installed at a level where it will always be submerged.

SPECIFICATIONS

CONTROL TYPE

On/Off Resistance Sensing:

DLA Models: Probe resistance below set point activates relay

DLB Models: Probe resistance above set point activates relay

Sensing Voltage: 18 VAC, max. RMS

Sensing Current: 2.0 mA, max. RMS

Sensitivity Adjustment: 1K to 250 K ohms $\pm 10\%$, factory set at 100k ohms $\pm 10\%$

INPUT

Operating Voltage: 24, 120 or 230 VAC, $\pm 10\%$

Power Consumption: 1.2 VA max.

Frequency: 50/60 Hz

OUTPUT

Type: Relay contacts, SPDT (1 form C)

Rating: 10 A resistive at 120, 240 VAC; 100 mA at 5 VDC min. load current

Life:

Mechanical: 5,000,000 cycles

Electrical: 100,000 min. at full load

PROTECTION

Isolation: 1500 VAC between probe and other terminals

MECHANICAL

Terminations: 8-pin octal plug

Mounting: Socket mount, part number MSO-0008P-012

ENVIRONMENTAL

Operating Temperature: -23°C to 55°C

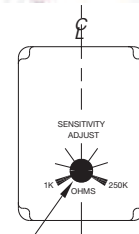

SENSITIVITY ADJUST ACCESS COVER

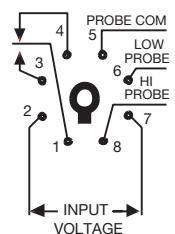
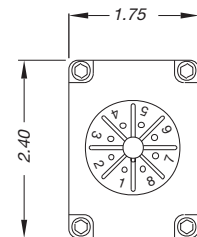
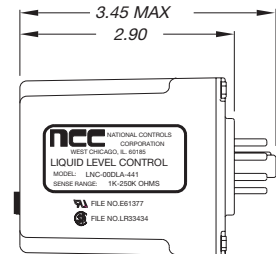

PIN CONFIGURATION
DWG:4787/9/93

ORDERING INFORMATION

LOGIC TYPE	INPUT VOLTAGE	PART NUMBER
DLA - Pump Down	24 VAC	LNC-00DLA-447
DLA - Pump Down	120 VAC	LNC-00DLA-441
DLA - Pump Down	230 VAC	LNC-00DLA-445
DLB - Pump Up	24 VAC	LNC-00DLB-447
DLB - Pump Up	120 VAC	LNC-00DLB-441
DLB - Pump Up	230 VAC	LNC-00DLB-445

ACCESSORY	PART NUMBER
Probe Holder with Ground	LLH-11383-010
Probe, 6" Long, 1/4" Dia., S.S.	LLP-06.00-OSS
Probe, 12" Long, 1/4" Dia., S.S.	LLP-12.00-OSS
Probe, 24" Long, 1/4" Dia., S.S.	LLP-24.00-OSS
Probe Assembly, Plastic Body	LLP-001/2-011
Octal Socket, Back Panel Mount	MSO-0008P-012
Hold Down Strap for Control	ASY-STRAP-7.00L

2-4 LIQUID LEVEL CONTROL SERIES

Resistance Sensors (Dual Probe) Models NS127, NS128 and NS143

FEATURES

- 100% functionally tested
- Isolated UL Class II sensing voltage
- 1/4" male fast-ons for circuit connection
- Conformal coating to protect circuit from harsh environments
- File #E61377 Model NS127 and NS128 only

Operating Logic: In the Model NS127 (Pump Down) the output relay is de-energized until the liquid reaches the high probe. When liquid touches the high probe, the output relay is activated until the level drops below the low probe.

In Models NS128 and NS143 (Pump Up) the output relay is energized until the liquid reaches the high probe. When the liquid touches the high probe, the output relay is deactivated until the level drops below the low probe.

If the tank is non-conductive, a third (common) probe must be installed at a level where it will always be submerged.

SPECIFICATIONS

CONTROL TYPE

On/Off Resistance Sensing:

NS127: Probe resistance below set point activates relay

NS128 and NS143: Probe resistance above set point activates relay

Sensing Voltage: 15 VAC, max. RMS

Sensing Current: 2 mA, max. RMS

Sensitivity Adjustment:

NS127 and NS128: Factory set at 100k ohms $\pm 10\%$

NS143: Factory set at 50 K ohms $\pm 10\%$

OUTPUT

Type:

NS127 and NS128: Isolated relay contacts, SPDT (1 Form C)

NS143: Relay contact SPST-NO switches L1 to normally open terminals

Rating:

NS127 and NS128: 10 A resistive at 120 VAC, 5 A resistive at 240 VAC

NS143: 5 A resistive at 120, 240 VAC, 100 mA at 5 VDC minimum load current

Life:

Mechanical:

NS143: 5,000,000 cycles

NS127, NS128: 10,000,000

Electrical: 100,000 min. at full load

INPUT

Operating Voltage: 120, 240 VAC, $\pm 10\%$

Power Consumption: 3.0 VA max.

Frequency: 50/60 Hz

PROTECTION

Isolation: 1500 VAC between probe and other terminals

MECHANICAL

Terminations: 1/4" x .032" male fast-ons

Mounting:

NS127 and NS128: 4 - .141" dia. mounting holes

NS143: 2 - .187" dia. mounting holes

ENVIRONMENTAL

Operating Temperature: -20°C to 55°C

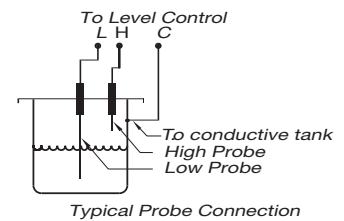
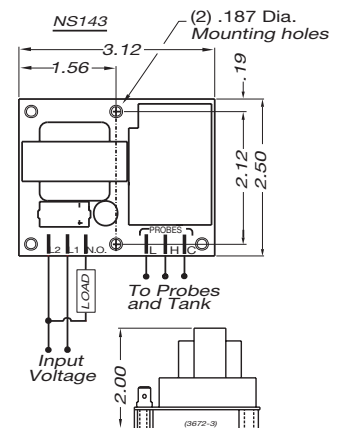
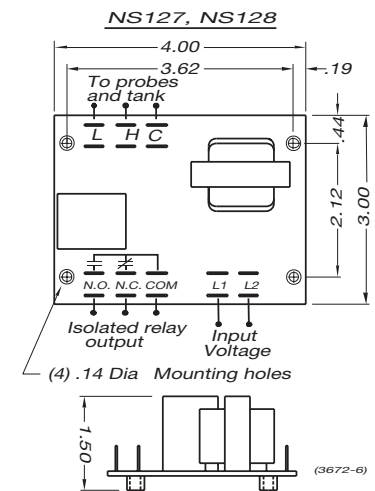
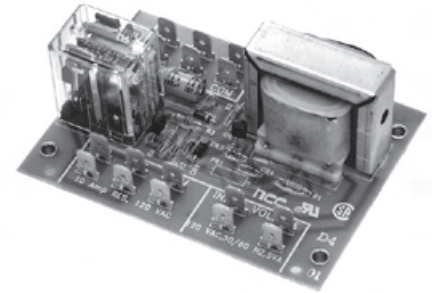

ORDERING INFORMATION



LOGIC TYPE	INPUT VOLTAGE	PART NUMBER
Pump Down	120 VAC	LNC-NS127-120
Pump Down	240 VAC	LNC-NS127-240
Pump Up	120 VAC	LNC-NS128-120
Pump Up	240 VAC	LNC-NS128-240
Pump Up	120 VAC	LNC-NS143-120
Pump Up	240 VAC	LNC-NS143-240

ACCESSORY	PART NUMBER
Probe Holder with Ground	LLH-11383-010
Probe, 6" Long, 1/4" Dia., S.S.	LLP-06.00-OSS
Probe, 12" Long, 1/4" Dia., S.S.	LLP-12.00-OSS
Probe, 24" Long, 1/4" Dia., S.S.	LLP-24.00-OSS
Probe Assembly, Plastic Body	LLP-001/2-011

Resistance Sensors (Pump Up Logic with Heater Burn Out Protection)

Models NS210 and NS211

FEATURES

- 100% functionally tested
- Solid state sensing circuitry
- Isolated UL Class II sensing voltage
- 1/4" male fast-ons for circuit connection
- Conformal coating to protect circuit from harsh environments
-   File #E61377

Operating Logic: Assuming an empty tank, upon application of voltage to the system, the fill output is turned on and the heater output is off. As the liquid fills the tank, and when it reaches the low probe (above heater), the heater output is turned on. The level will rise until it reaches the high probe causing the fill output to turn off. As liquid is removed from the tank, 2 to 4 seconds after it breaks contact with the high probe, the fill output is turned on and stays on until the liquid reaches the high probe. This time delay eliminates fill output chatter if the liquid is splashing.

If the tank is non-conductive, a third (common) probe must be installed at a level where it will always be submerged.

SPECIFICATIONS

CONTROL TYPE

On/Off Resistance Sensing:

On low probe: probe resistance below set point activates heater output
On high probe: probe resistance above set point activates fill output after a 2 to 4 sec. delay

Sensing Voltage: 15 VAC, max. RMS

Sensing Current: 2 mA, max. RMS

Sensitivity Adjustment: Factory set at 50 K ohms $\pm 10\%$

INPUT

Operating Voltage: 24, 120, 240 VAC, $\pm 10\%$

Power Consumption: 3.0 VA max.

Frequency: 50/60 Hz

OUTPUT

Type: Relay contacts, switch loads to L1

Rating: 5 A resistive at 240 VAC

Life:

Mechanical: 5,000,000 cycles

Electrical: 100,000 min. at full load

PROTECTION

Isolation: 1500 VAC between probe and other terminals

MECHANICAL

Terminations: 1/4" x .032" male fast-ons

Mounting: 4 - .141" dia. mounting holes

ENVIRONMENTAL

Operating Temperature: 0°C to 55°C

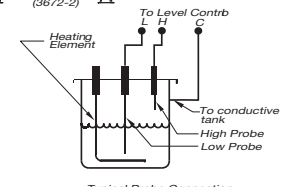
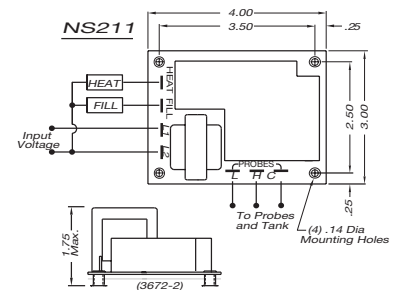
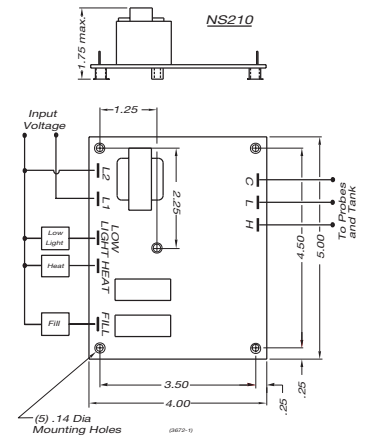
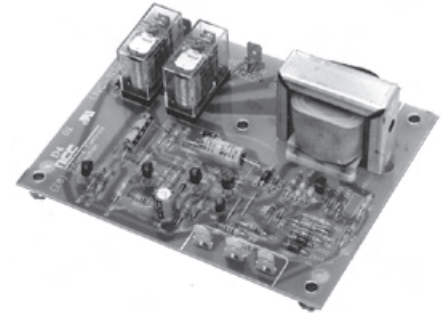

ORDERING INFORMATION



LOGIC TYPE	INPUT VOLTAGE	PART NUMBER
Pump Up	24 VAC	LNC-NS210-024
Pump Up	120 VAC	LNC-NS210-120
Pump Up	240 VAC	LNC-NS210-240
Pump Up	120 VAC	LNC-NS211-120

ACCESSORY	PART NUMBER
Probe Holder with Ground	LLH-11383-010
Probe, 6" Long, 1/4" Dia., S.S.	LLP-06.00-OSS
Probe, 12" Long, 1/4" Dia., S.S.	LLP-12.00-OSS
Probe, 24" Long, 1/4" Dia., S.S.	LLP-24.00-OSS
Probe Assembly, Plastic Body	LLP-001/2-011

Resistance Sensors (Dual Probe)

Models NS129, NS132 and NS139

FEATURES

- 100% functionally tested
- Solid state sensing circuitry
- Isolated UL Class II sensing voltage
- Adjustable sensitivity by Trimpot
- #6 screw terminal connections
- Conformal coating to protect circuit from harsh environments
-   File #E61377

Operating Logic: In Models NS129 and NS139 (Pump Down) the output relay is de-energized until the liquid reaches the high probe. When liquid touches the high probe, the output relay is activated until the level drops below the low probe.

In Models NS132 (Pump Up) the output relay is energized until the liquid reaches the high probe. When the liquid touches the high probe, the output relay is deactivated until the level drops below the low probe.

If the tank is non-conductive, a third (common) probe must be installed at a level where it will always be submerged.

SPECIFICATIONS

CONTROL TYPE

On/Off Resistance Sensing:

NS129 and NS139: Probe resistance below set point activates relay

NS132: Probe resistance above set point activates relay

Sensing Voltage: 15 VAC, max. RMS

Sensing Current: 2.0 mA, max. RMS

Sensitivity Adjustment: Adjustable by a Trimpot from .1-100 K ohms +10%, -0%

INPUT

Operating Voltage: 120, 240 VAC, ±10%

Power Consumption: 11 VA max. for 120 VAC units

Frequency: 50/60 Hz

OUTPUT

Type:

NS129 and NS132: Relay contacts SPDT (1 Form C)

NS139: Relay contacts DPDT (2 Form C)

Rating: 10 A resistive at 120 VAC; 5 A resistive at 240 VAC; 100 mA at 5 VDC min. load current

Life:

Mechanical: 10,000,000 cycles

Electrical: 100,000 min. at full load

PROTECTION

Isolation: 1500 VAC between probe and other terminals

MECHANICAL

Terminations: Terminal blocks with #6 screw connections

Mounting: 4-.141" dia. mounting holes

ENVIRONMENTAL

Operating Temperature: -20°C to 55°C

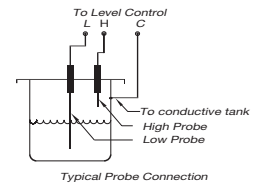
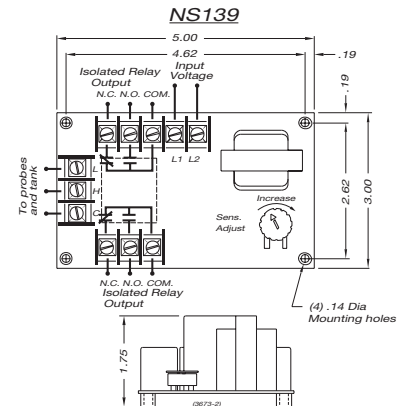
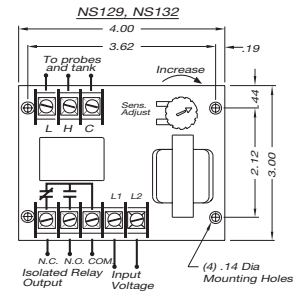
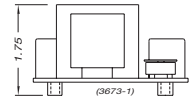
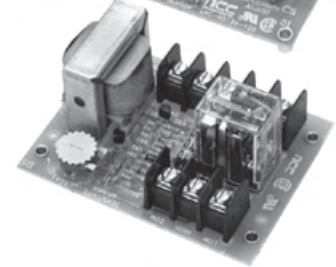
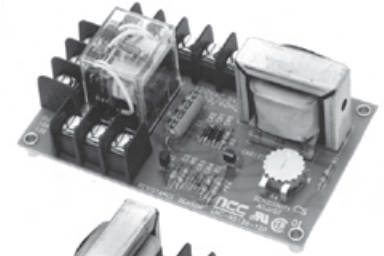

ORDERING INFORMATION



LOGIC TYPE	INPUT VOLTAGE	PART NUMBER
Pump Down	120 VAC	LNC-NS129-120
Pump Down	240 VAC	LNC-NS129-240
Pump Down	120 VAC	LNC-NS139-120
Pump Up	120 VAC	LNC-NS132-120
Pump Up	240 VAC	LNC-NS132-240

ACCESSORY	PART NUMBER
Probe Holder with Ground	LLH-11383-010
Probe, 6" Long, 1/4" Dia., S.S.	LLP-06.00-OSS
Probe, 12" Long, 1/4" Dia., S.S.	LLP-12.00-OSS
Probe, 24" Long, 1/4" Dia., S.S.	LLP-24.00-OSS
Probe Assembly, Plastic Body	LLP-001/2-011

Resistance Sensors (Dual Probe, Dual Logic)

Model NS146

FEATURES

- 100% functionally tested
- Solid state sensing circuitry
- Isolated UL Class II sensing voltage
- Selectable logic
- Conformal coating to protect circuit from harsh environments
-   File #E61377

Operating Logic: By switching a program wire from position A to B, the user can select either pump down (Mode A), or pump up (Mode B) logic.

In Mode A, the load is de-energized until the liquid reaches the high probe. When liquid touches the high probe, the load is activated until the level drops below the low probe.

In Mode B, the load is energized until the liquid reaches the high probe. When liquid reaches the high probe, the load is deactivated until the level drops below the low probe.

If the tank is non-conductive, a third (common) probe must be installed at a level where it will always be submerged.

SPECIFICATIONS

CONTROL TYPE

On/Off Resistance Sensing:

Mode A: Probe resistance below set point activates load

Mode B: Probe resistance above set point activates load.

Sensing Voltage: 30 VAC, max. RMS

Sensing Current: 1 mA, max. RMS

Sensitivity Adjustment: Factory set at 50 K ohms $\pm 20\%$

INPUT

Operating Voltage: 120, 240 VAC, $\pm 10\%$

Power Consumption: 3.0 VA max.

Frequency: 50/60 Hz

OUTPUT

Type: Single pole solid state switch

Rating: 7.5 A resistive at 120, 240 VAC; 1/3 hp rated at 120, 240 VAC

Life:

Electrical: 1,000,000 min. at full load

Note: Contact factory for higher rating requirements.

PROTECTION

Isolation: 1500 VAC between probe and other terminals

Transient Voltage: Protected by 30 joule metal oxide varistor

Coating: Conformally coated with RTV to protect against moisture

MECHANICAL

Terminations: #8 screw for input voltage, .25" x .032" fast-ons for load, .187" x .020" fast-ons for probes

Mounting: 2-3/16" slots on 3.5" center in aluminum chassis

ENVIRONMENTAL

Operating Temperature: -20°C to 55°C

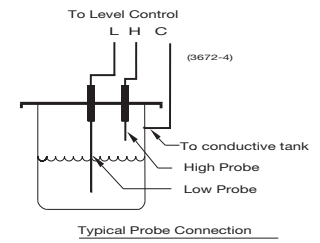
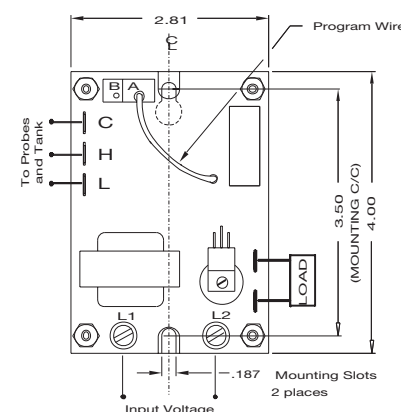
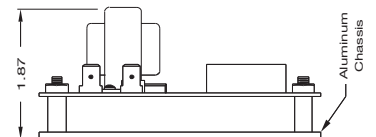

ORDERING INFORMATION

LOGIC TYPE	INPUT VOLTAGE	PART NUMBER
Pump Down/Pump Up	120 VAC	LNC-NS146-120
Pump Down/Pump Up	240 VAC	LNC-NS146-240

ACCESSORY	PART NUMBER
Probe Holder with Ground	LLH-11383-010
Probe, 6" Long, 1/4" Dia., S.S.	LLP-06.00-OSS
Probe, 12" Long, 1/4" Dia., S.S.	LLP-12.00-OSS
Probe, 24" Long, 1/4" Dia., S.S.	LLP-24.00-OSS
Probe Assembly, Plastic Body	LLP-001/2-011

Program wire selects Pump Down Mode A or Pump Up Mode B.

Resistance Sensors (Dual Probe, Dual Voltage) 1hp Solid State Output Model NS141

FEATURES

- 100% functionally tested
- 16 A 1 hp solid state output rating
- 120/240, 100/200 VAC operation voltages
- Solid state sensing circuitry
- Isolated UL Class II sensing voltage
- Adjustable sensitivity by Trimpot
- 1/4" male fast-ons for circuit connection
- Conformal coating to protect circuit from harsh environments
-  File #E61377

Operating Logic: In Model NS141-A10 (Pump Down) the load is de-energized until the liquid reaches the high probe. When liquid touches the high probe, the load is activated until the level drops below the low probe.

Model NS141-B10 (Pump Up): The load is energized until the liquid reaches the high probe. When liquid touches the high probe, the load is deactivated until the level drops below the low probe.

On both models a red light is activated when the load is off. If the tank is non-conductive, a third (common) probe must be installed at a level where it will always be submerged.

SPECIFICATIONS

CONTROL TYPE

On/Off Resistance Sensing:

NS141-A10/A100: Probe resistance below set point activates relay

NS141-B10/B100: Probe resistance above set point activates relay

Sensing Voltage: 30 VAC, max. RMS

Sensing Current: 1 mA, max. RMS

Sensitivity Adjustment: Factory set at 50 K ohms, $\pm 20\%$

OUTPUT

Type: Single-pole solid state switch

Rating: 16 A 1 hp at 120, 240 VAC

Life:

Electrical: 1,000,000 min. at full load

INPUT

Operating Voltage:

NS141-A10: 120 VAC, $\pm 10\%$, between COM and 120 terminals

NS141-B10: 240 VAC, $\pm 10\%$, between COM and 240 terminals

NS141-A100: 100 VAC, $\pm 10\%$, between COM and 120 terminals

NS141-B100: 200 VAC, $\pm 10\%$, between COM and 240 terminals

Power Consumption:

NS141-A10/B10: 3.0 VA max.

NS141-A100/B100: 4.0 VA max.

Frequency: 50/60 Hz

PROTECTION

Isolation: 1500 VAC between probe and other terminals

Transient Voltage: Protected by a 30 joule metal oxide varistor

MECHANICAL

Terminations: 1/4" x .032" male fast-ons for input voltage and load, .187" x .020" fast-ons for probes

Mounting: 2 - 3/16" slots on 3.5" center in aluminum chassis

ENVIRONMENTAL

Operating Temperature: 0°C to 65°C

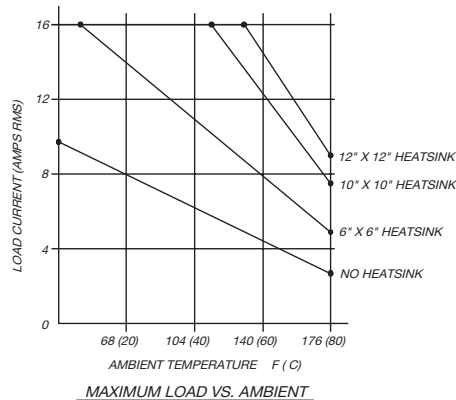

4808/12/94

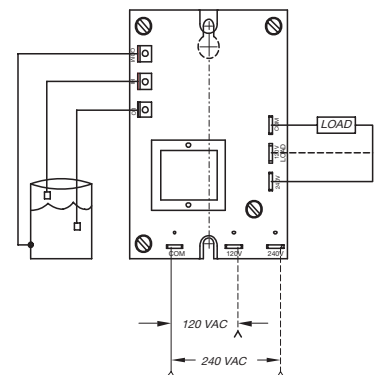
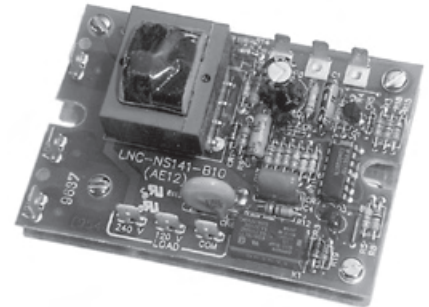

INPUT VOLTAGE

NOTE: MUST USE COM TO 120V OUTPUT WHEN 120V INPUT IS USED
MUST USE COM TO 240V OUTPUT WHEN 240V INPUT IS USED

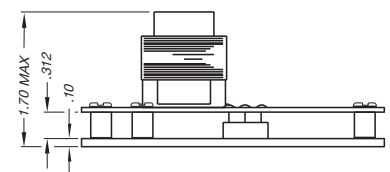
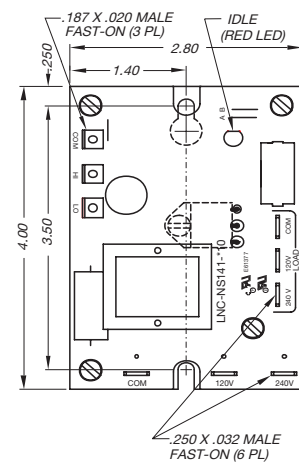

ORDERING INFORMATION



LOGIC TYPE	INPUT VOLTAGE	PART NUMBER
Pump Down	120/240 VAC	LNC-NS141-A10
Pump Up	120/240 VAC	LNC-NS141-B10
Pump Down	100/200 VAC	LNC-NS141-A100
Pump Up	100/200 VAC	LNC-NS141-B100

ACCESSORY	PART NUMBER
Probe Holder with Ground	LLH-11383-010

Resistance Sensors (Single Probe, Pump Up Logic with Time Delayed Output)

Models NS156 and NS159

FEATURES

- 100% functionally tested
- Solid state sensing circuitry
- Isolated UL Class II sensing voltage
- 1/4" male fast-ons for circuit connection
- Conformal coating to protect circuit from harsh environments
-   File #E61377

Operating Logic: As liquid is removed from a tank and contact with a probe is interrupted, a fixed time delay is started. At the end of the time delay, the output is activated until the level rises and contacts the probe.

On Model NS159, when the output is turned on, a fault timer is started. If the output is still on at the end of the fault time, the fault timer will shut the output off until voltage is removed and re-applied to the control system. The purpose of the fault timer is to eliminate overflow due to an open probe.

If the tank is non-conductive, a second (common) probe must be installed at a level where it will always be submerged.

SPECIFICATIONS

CONTROL TYPE

On/Off Resistance Sensing: Probe resistance above set point activates fill output after a fixed time delay

Sensing Voltage: 15 VAC, max. RMS

Sensing Current: 2 mA, max. RMS

Sensitivity Adjustment:

NS156: Factory set at 100 K ohms $\pm 10\%$

NS159: Factory set at 500 K ohms $\pm 10\%$

Activate Time Delay:

NS156: 5 sec. ± 1 sec.

NS159: 1 sec. ± 5 sec.

Fault Timer Delay, NS159: 300 sec. $\pm 15\%$

Contact factory for other sensitivity and time delay requirements.

INPUT

Operating Voltage: 120, 240 VAC, $\pm 10\%$

Power Consumption: 3.0 VA max.

Frequency: 50/60 Hz

OUTPUT

Type:

NS156: Solid state switch, .75 A at 25°C, .34 A at 77°C

NS159: Relay contact, 2 A at 120 VAC

Life:

NS156: 1,000,000 cycles min. at full load

NS159: 300,000 cycles min. at full load

PROTECTION

Isolation: 1500 VAC between probe and other terminals

Transient Voltage: Protected by 30 joule metal oxide varistor

Coating: Conformally coated with RTV to protect against moisture

MECHANICAL

Terminations: 1/4" x .032" fast-ons

Mounting: 2 - .218" dia. holes

ENVIRONMENTAL

Operating Temperature:

NS156: +5°C to 77°C

NS159: +5°C to 65°C

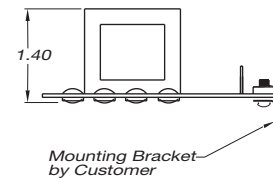

Mounting Bracket by Customer

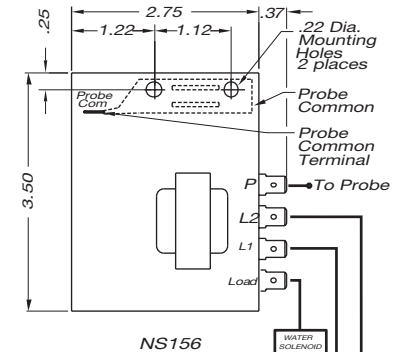

NS156

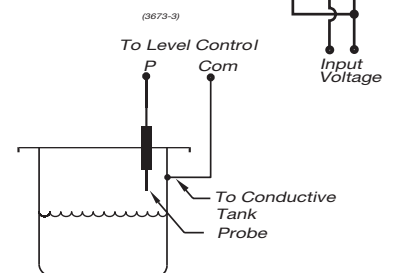

Typical Probe Connection

ORDERING INFORMATION

LOGIC TYPE	INPUT VOLTAGE	PART NUMBER
Pump Up	120 VAC	LNC-NS156-120
Pump Up	240 VAC	LNC-NS156-240
Pump Up/Fault Timer	120 VAC	LNC-NS159-120

ACCESSORY	PART NUMBER
Probe Holder with Ground	LLH-11383-010
Probe, 6" Long, 1/4" Dia., S.S.	LLP-06.00-OSS
Probe, 12" Long, 1/4" Dia., S.S.	LLP-12.00-OSS
Probe, 24" Long, 1/4" Dia., S.S.	LLP-24.00-OSS
Probe Assembly, Plastic Body	LLP-001/2-011

Resistance Sensors (Low Water Detect Logic) Model NS157

FEATURES

- 100% functionally tested
- Solid state sensing circuitry
- Isolated UL Class II sensing voltage
- 1/4" male fast-ons for circuit connection
- Conformal coating to protect circuit from harsh environments
- File #E61377

Operating Logic: The output relay is activated when liquid touches the probe. As the liquid level drops below the probe, the relay is deactivated.

If the tank is non-conductive, a second (common) probe must be installed at a level where it will always be submerged.

SPECIFICATIONS

CONTROL TYPE

On/Off Resistance Sensing: Probe resistance below set point activates output relay

Sensing Voltage: 20 VAC, max. RMS

Sensing Circuit: 2 mA, max. RMS

Sensitivity Adjustment: Factory set at 50 K ohms $\pm 10\%$

INPUT

Operating Voltage: 120, 240 VAC, $\pm 10\%$

Power Consumption: 3.0 VA max.

Frequency: 50/60 Hz

OUTPUT

Type: SPDT relay, isolated contacts

Rating: 5 A resistive at 120 VAC 100 mA at 5 VDC min. load current

Life:

Mechanical: 2,000,000 cycles

Electrical: 100,000 min. at full load

PROTECTION

Isolation: 1500 VAC between probe and other terminals

MECHANICAL

Terminations: 1/4" x .032" male fast-ons

Mounting: 4 - .141" dia. mounting holes

ENVIRONMENTAL

Operating Temperature: 0°C to 70°C

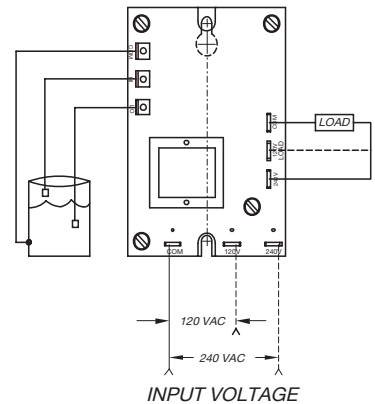
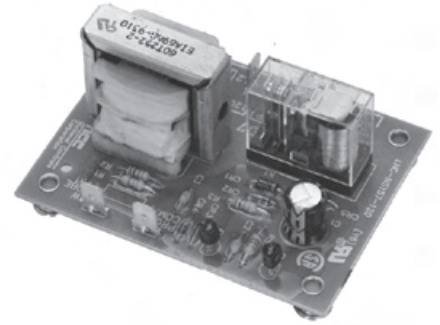

NOTE: MUST USE COM TO 120V OUTPUT WHEN 120V INPUT IS USED
MUST USE COM TO 240 V OUTPUT WHEN 240 V INPUT IS USED

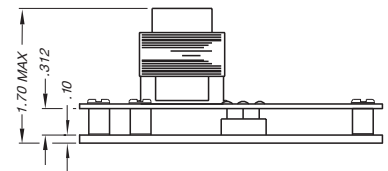
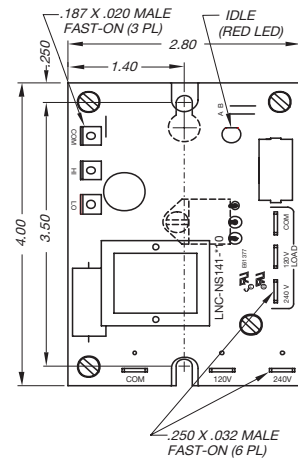

ORDERING INFORMATION

LOGIC TYPE	INPUT VOLTAGE	PART NUMBER
Low Water Detect	120 VAC	LNC-NS157-120
Low Water Detect	240 VAC	LNC-NS157-240

ACCESSORY	PART NUMBER
Probe Holder with Ground	LLH-11383-010
Probe, 6" Long, 1/4" Dia., S.S.	LLP-06.00-OSS
Probe, 12" Long, 1/4" Dia., S.S.	LLP-12.00-OSS
Probe, 24" Long, 1/4" Dia., S.S.	LLP-24.00-OSS
Probe Assembly, Plastic Body	LLP-001/2-011

Socket

ORDERING INFORMATION

8-pin Circular Socket, DIN Rail Mountable	MSO-0008P-012
---	---------------

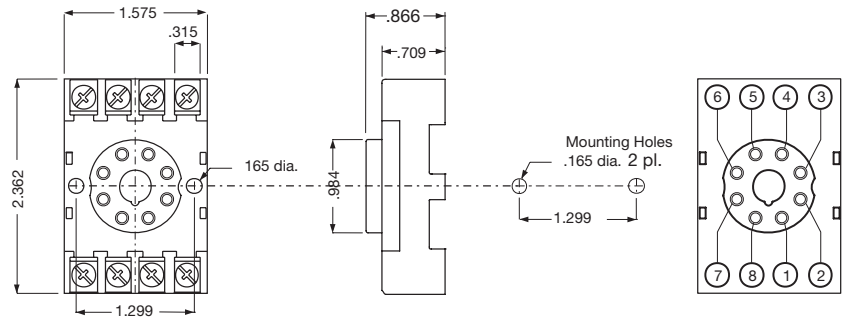

Probe Holder

Metal parts are 300 series non-magnetic stainless steel. These internally conductive glass-seal probe holders will withstand up to 2500 psi or 700°F.

The probe holders are rated at 250 V and can be used in steam applications up to 250 psi.

ORDERING INFORMATION

Probe Holder with Ground	LLH-11383-010
--------------------------	---------------

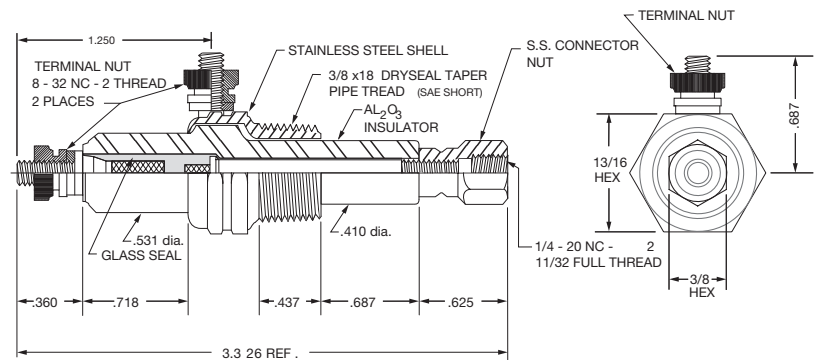

Probes

ORDERING INFORMATION

Stainless Steel 6" Probe	LLP-06.00-OSS
Stainless Steel 12" Probe	LLP-12.00-OSS
Stainless Steel 24" Probe	LLP-24.00-OSS

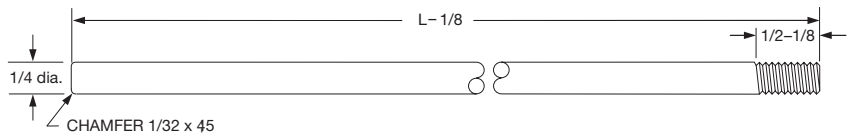

Hold-down Strap

ORDERING INFORMATION

Hold-down Strap for Plug-In Level Sensors	ASY-STRAP-7.00L
---	-----------------

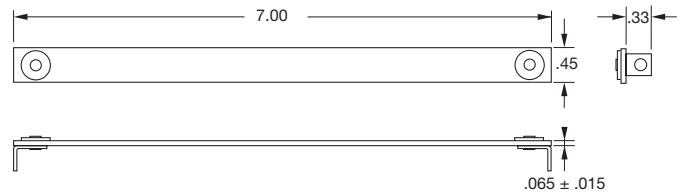

Button Probe

ORDERING INFORMATION

Button Probe	LLP-001/2-011
--------------	---------------

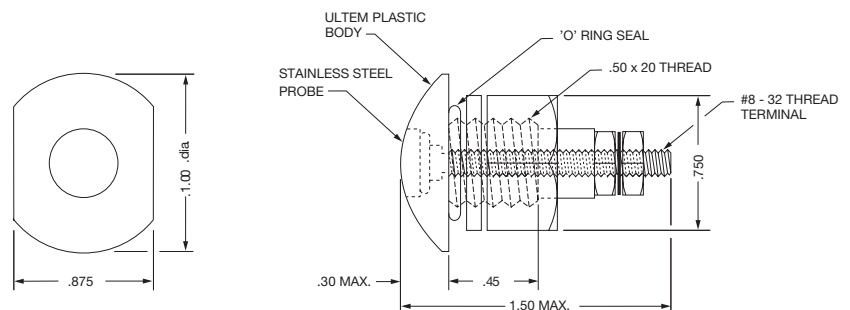



AMETEK NCC Digital Temperature Indicators, Controllers and Timers allow the constant monitoring of temperature for various equipment applications. These controls are built to withstand rugged environments and still remain accurate, providing a high level of quality performance.

AMETEK NCC offers impressive factory back-up support and our parts inventory and product availability is unsurpassed. With over 250 stocking distributor outlets, serious downtime problems can virtually be eliminated. Technical assistance for design and engineering help is readily available through our **toll free number: 800-323-2593**.



Common Applications:

- *Walk-in Refrigerators*
- *Coolers/Freezers*
- *Food Warmers*
- *Convection Ovens*
- *Testing Chambers/Ovens*
- *Dry Cleaning Machinery*
- *Testing (Brew Temperature)*
- *Commercial Dishwashers*
- *Coffee Urns*
- *Heating and Air Conditioning Testing*
- *Kitchen Grease Filters*
- *Heat Sensitive Equipment*

Digital Temperature Controller

TC140 Series

FEATURES

- Compact design
- Easy-to-read 4-digit LED display
- Time displays in hr./min.
- Temperature display in Fahrenheit or Celsius
- Non-volatile storage of programmed parameters
- Watchdog timer ensures reliability
- 4-button, moisture-resistant keyboard using snap-action sealed switches
- Diagnostic messages for fault conditions
- Front panel keyboard programming of time and temperature
- HEAT ON indicator
- Accurate and durable thermocouple temperature sensing
- Convenient operating voltage ranges
- Heavy duty stainless steel front panel
-   File #E104595

The Model TC140 is a Digital Temperature Controller which features an independent count-up timer. The controller uses a Type K thermocouple and is microprocessor controlled. The regulation temperature can be set in one degree increments within specified limits. Hysteresis, Offset and Fahrenheit or Celsius are selected via front panel switches. The HEAT ON light indicates output relay activation. Actual sensed temperature is normally shown on the digital display. The control has diagnostic messages for open probe and memory failure.

Operating Logic: The timer function is started by pressing the TIME START button. The digital display will then alternate between probe temperature and elapsed time in hours and minutes. The timer function is cancelled by pressing the TIME START button again.

Setting Regulation Point: Press the TEMP button momentarily. The display will flash SET and PNT briefly then flash the setpoint value. The ▲ and ▼ buttons can now be used to adjust the temperature regulating setpoint. Press the TEMP button again to cause the control to regulate to the new setpoint.

Setting Hysteresis: The turn-on and turn-off temperature around a setpoint can be

separately adjusted to $\pm 20^{\circ}\text{F}$. Press and hold the ▲, ▼ and TEMP buttons for .5 second. The display will alternate between ON and the turn-on value. The ▲ and ▼ buttons can now be used to change this value. Press the TEMP button again and the OFF value will be displayed. The ▲ and ▼ buttons can now be used to change the OFF value. Pressing the TEMP button again will return the control to normal operation and will store the new settings. The hysteresis is set to -1°F , $+0^{\circ}\text{F}$ as shipped from the factory.

Setting Offset: The displayed value can be changed by $\pm 20^{\circ}\text{F}$ relative to actual sensed temperature value. This feature corrects for disparity of location of the probe and the volumetric center of the heating chamber. Press and hold the TIME and TEMP buttons, then also press and hold the ▲ and ▼ buttons. After one second the display will flash OFF and SET briefly then will flash the offset value. At this point, the ▲ and ▼ buttons can be used to adjust the offset. Pressing the TEMP button programs the control for the new value. The offset is set to 0 as shipped from the factory.



Diagnostic Messages: An open probe will cause the digital display to show PROB and will disable the output until input voltage is removed and re-applied. If a memory loss or failure occurs, the digital display will show FAIL and the output will be disabled. Input voltage should be removed and re-applied. If the FAIL message is gone, recheck programmed parameters and resume operation. If the FAIL message reappears, contact the factory for service.

ORDERING INFORMATION

INPUT VOLTAGE	PART NUMBER
18 to 28 VAC	TNC-TC140-A010
90 to 135 VAC	TNC-TC140-A120
198 to 242 VAC	TNC-TC140-A220

ACCESSORY	PART NUMBER
Type K Thermocouple, Bead Tip Probe, 6'	ASP-CH/AL-011
Type K Thermocouple, Perforated Probe, 24"	ASP-CH/AL-013
Type K Thermocouple, Probe with 6' Lead	ASP-CH/AL-016
Type Ke Thermocouple, Probe with 10' Lead	ASP-CH/AL-017
Type K Thermocouple, Perforated Probe, 48"	ASP-CH/AL-018
Type K Thermocouple, Perforated Probe, 72"	ASP-CH/AL-019
Type K Thermocouple, Probe with Flange	ASP-CH/AL-020
Type K Thermocouple, Ring Lug Mount	ASP-CH/AL-021

*All transformer wires are 8" long: 120V Primary Black/White; 220V Primary Black/Black

SPECIFICATIONS

CONTROL/TIMING

Temperature Control Mode: ON/OFF with hysteresis

Temperature Sensor: Type K thermocouple with special limits of error is recommended for max. accuracy

Maximum Timing Interval: 99 hr.: 99 min.

Minimum Timing Accuracy: $\pm 2\%$

INPUT

Operating Voltage:

TNC-TC140-010: 18-28 VAC, 60Hz

TNC-TC140-120: 95-135 VAC, 60Hz

TNC-TC140-220: 198-242 VAC, 60Hz

Power Consumption:

TNC-TC140-010: 10 VA max.

TNC-TC140-120/220: 30 VA max.

Resolution: $\pm 1^\circ\text{F}$

Temperature Sensing Range: 50°F to 700°F
(10°C to 371°C)

Temperature Range Display Accuracy: $\pm 5.4^\circ\text{F}$
($\pm 3.0^\circ\text{C}$) max. over operating voltage and ambient temperature range

Temperature Regulating Range: 100°F to 601°F
(38°C to 316°C)

Selecting for °F or °C: Press and hold both ▲ and ▼ buttons until temperature scale changes; release buttons

OUTPUT

Heater Output Rating: SPST normally open isolated contact 1 A at 24 to 250 VAC

ENVIRONMENTAL

Ambient Operating Range: 5°C to 65°C

Ambient Storage Range: -40°C to 85°C

MECHANICAL

Termination Type: Input voltage and heater output contacts 1/4" x .032" PC mount fast-ons

Probe: #6 screw with clamp

Mounting: Two center mountings (.187 dia.)

Front Panel Material: 18 gauge stainless steel

Keyboard: 4-button moisture resistant using snap action sealed switches behind a polyester graphic overlay for maximum reliability

Display: 4-digit, seven segment red LED

Digit Height: .56 inches

ELECTRICAL

Simple wire hook-up

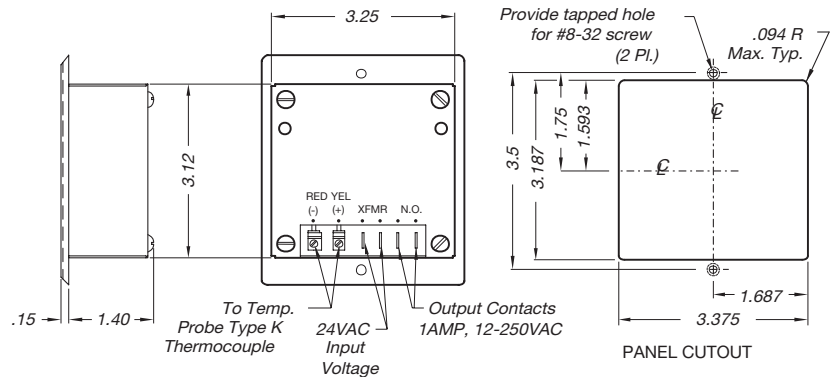
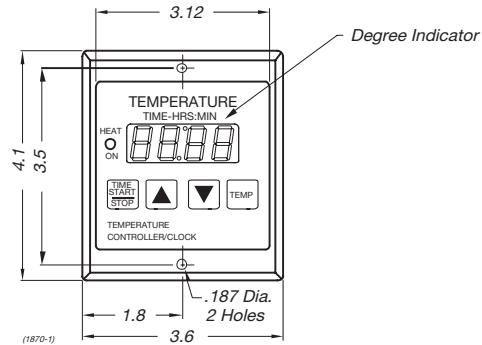

TNC-TC140-010

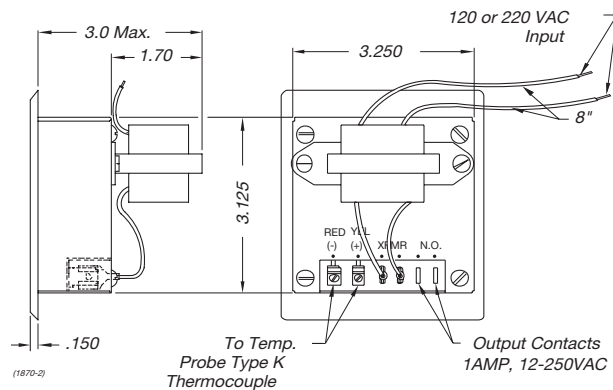



TNC-TC140-120 AND TNC-TC140-220

Digital Temperature Controller

TC142 Series

FEATURES

- Compact design
- Easy-to-read 4-digit LED display
- Temperature display in Fahrenheit or Celsius
- Non-volatile storage of programmed parameters
- Watchdog timer ensures reliability
- 4-button, moisture-resistant keyboard using snap-action sealed switches
- Diagnostic messages for fault conditions
- Front panel keyboard programming of time and temperature
- HEAT ON indicator
- Accurate and durable thermocouple temperature sensing
- Convenient operating voltage ranges
- Heavy duty stainless steel front panel
-   File #E104595

The Model TC142 is a Digital Temperature Controller. The controller uses a Type K thermocouple and is microprocessor controlled. The regulation temperature can be set in one degree increments within specified limits. Hysteresis, Offset and Fahrenheit or Celsius are selected via front panel switches. The HEAT ON light indicates output relay activation. The regulation temperature is normally shown on the digital display. To view the sensed temperature, press the TEMP button. The control has diagnostic messages for open probe and memory failure.

Setting Regulation Point: Press the PROG button momentarily. The display will flash SET and PNT briefly then flash the setpoint value. The ▲ and ▼ buttons can now be used to adjust the temperature regulating setpoint. Press the PROG button again to cause the control to regulate to the new setpoint. To view or change other functions while in program mode, press ADV button to scroll to that function.

Setting Hysteresis: The turn-on and turn-off temperature around a setpoint can be separately adjusted to $\pm 20^{\circ}\text{F}$. Press and hold the PROG button for .5 second. Scroll to DEAD BAND using the ADV button. The display will alternate between ON and the turn-on value. The ▲ and ▼ buttons can now be used to change this value. Press the

ADV button again and the OFF value will be displayed. The ▲ and ▼ buttons can now be used to change the OFF value. Pressing the PROG button again will return the control to normal operation and will store the new settings. The hysteresis is set to -1°F , $+0^{\circ}\text{F}$ as shipped from the factory.

Setting Offset: The displayed value can be changed by $\pm 20^{\circ}\text{F}$ relative to actual sensed temperature value. This feature corrects for disparity of location of the probe and the volumetric center of the heating chamber. Press and hold the PROG button for .5 second. Scroll to the offset function using the ADV button. The display will flash OFF and SET briefly then will flash the offset value. At this point, the ▲ and ▼ buttons can be used to adjust the offset. Pressing the TEMP button programs the control for the new value. The offset is set to 0 as shipped from the factory.

Diagnostic Messages: An open probe will cause the digital display to show PROB and will disable the output until input voltage is removed and re-applied. If a memory loss or failure occurs, the digital display will show FAIL and the output will be disabled. Input voltage should be removed and re-applied. If the FAIL message is gone, recheck programmed parameters and resume operation. If the FAIL message reappears, contact the factory for service.



ORDERING INFORMATION

INPUT VOLTAGE	PART NUMBER
18 to 28 VAC	TNC-TC142-A010
90 to 135 VAC	TNC-TC142-A120
198 to 242 VAC	TNC-TC142-A220

ACCESSORY	PART NUMBER
Transformer - 120V, 60Hz Primary	B24-NO120-011
Transformer - 240V, 50/60Hz Primary	B24-NO220-011
Type K Thermocouple, Bead Tip Probe, 6'	ASP-CH/AL-011
Type K Thermocouple, Perforated Probe, 24"	ASP-CH/AL-013
Type K Thermocouple, Probe with 6' Lead	ASP-CH/AL-016
Type Ke Thermocouple, Probe with 10' Lead	ASP-CH/AL-017
Type K Thermocouple, Perforated Probe, 48"	ASP-CH/AL-018
Type K Thermocouple, Perforated Probe, 72"	ASP-CH/AL-019
Type K Thermocouple, Probe with Flange	ASP-CH/AL-020
Type K Thermocouple, Ring Lug Mount	ASP-CH/AL-021

**All transformer wires are 8" long: 120V Primary Black/White; 220V Primary Black/Black*

SPECIFICATIONS

CONTROL/TIMING

Temperature Control Mode: ON/OFF with hysteresis

Temperature Sensor: Type K thermocouple with special limits of error is recommended for max. accuracy

Maximum Timing Interval: 99 hr.: 99 min.

Minimum Timing Accuracy: $\pm 2\%$

INPUT

Operating Voltage:

TNC-TC142-010: 18-28 VAC, 60Hz

TNC-TC142-120: 95-135 VAC, 60Hz

TNC-TC142-220: 198-242 VAC, 60Hz

Power Consumption:

TNC-TC142-010: 10 VA max.

TNC-TC142-120/220: 30 VA max.

Resolution: $\pm 1^\circ\text{F}$

Temperature Sensing Range: 50°F to 700°F
(10°C to 371°C)

Temperature Range Display Accuracy: $\pm 5.4^\circ\text{F}$
($\pm 3.0^\circ\text{C}$) max. over operating voltage and ambient temperature range

Temperature Regulating Range: 100°F to 601°F
(38°C to 316°C)

Selecting for °F or °C: Press and hold both ▲ and ▼ buttons until temperature scale changes; release buttons

OUTPUT

Heater Output Rating: SPST normally open isolated contact 1A at 24 to 250 VAC

ENVIRONMENTAL

Ambient Operating Range: 5°C to 65°C

Ambient Storage Range: -40°C to 85°C

MECHANICAL

Termination Type: Input voltage and heater output contacts 1/4" x .032" PC mount fast-ons

Probe: #6 screw with clamp

Mounting: Two center mountings (.187 dia.)

Front Panel Material: 18 gauge stainless steel

Keyboard: 4-button moisture resistant using snap action sealed switches behind a polyester graphic overlay for max. reliability

Display: 4-digit, seven segment red LED

Digit Height: .56 inches

ELECTRICAL

Simple wire hook-up

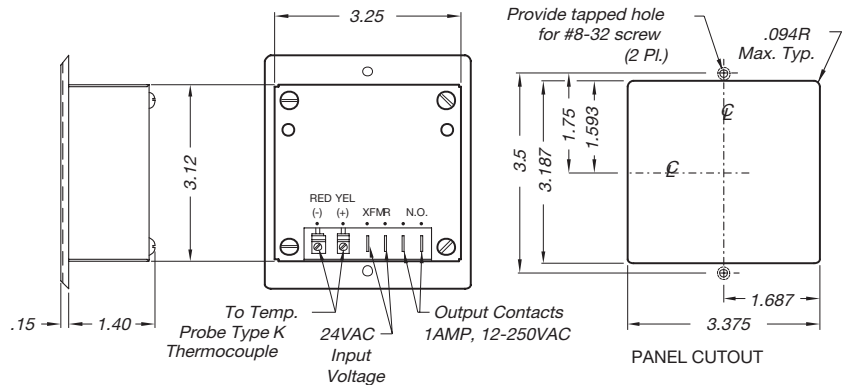
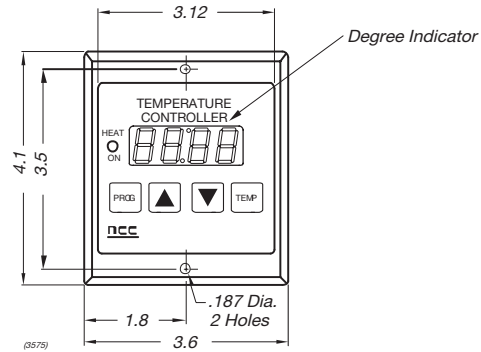

TNC-TC142-010

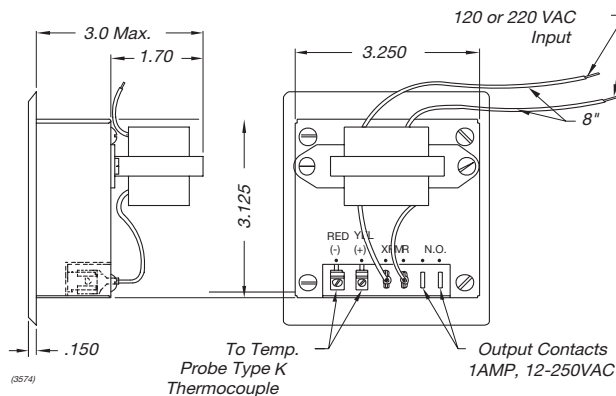

TNC-TC142-120 AND TNC-TC142-220

Panel Mount Digital Thermometer Models TM165 and TM166

FEATURES

- Heavy-duty stainless steel front plate and all metal case for rugged environments
- Easy-to-read digital display
- Temperature sensing range of -25°F to 99°F (-32°C to 38°C)
- Front panel selectable °F to °C operation
- Alarm temperature setting; programmable via front panel buttons
- Alarm relay
- Low voltage AC or DC operation
- TM166 fits in a standard electrical box

National Controls' panel mount thermometer allows the constant monitoring of temperature in critical environments and equipment, enabling a higher degree of operating efficiency.

The high temperature alarm alerts personnel to a high temperature condition, protecting temperature sensitive equipment and operations. When the temperature rises to the setpoint temperature, the display flashes and an audible alarm sounds. When the temperature falls below the setpoint temperature, the alarm condition ceases. If during the alarm condition, it is desired to turn off the alarm, depressing the front panel push-button will interrupt the audible alarm for approximately 2-1/2 hours, but the display will continue to flash.

The heavy-duty stainless steel front plate protects the unit from mechanical shock and abuse, and is designed to blend visually with other stainless steel equipment.

The thermometer can be mounted directly on the equipment it is monitoring, or on a remote panel up to 250 feet away. The thermometer is powered from low-voltage AC or DC, thus eliminating the high costs of installation to NEC or other high voltage electrical standard wiring.

The control can also detect an open or shorted temperature probe. If the probe is open or shorted the display will show PRB, the alarm will sound and the relay contacts will close. The alarm will continue to sound until the probe error condition is corrected. In addition, the output relay's contacts will close during a high temperature ALARM condition.

Setting the High Temperature Alarm: On the front of the TM165 and TM166 there are up and down arrow buttons for changing the set point temperature. The set point can be adjusted to any temperature within the specified range of that particular model.

Setting °F or °C Operation: Using the front panel buttons the display can be adjusted to display temperature in °F or °C.

SPECIFICATIONS

Temperature Sensing Range: -25°F to 99°F (-32°C to 38°C)

Temperature Reading Accuracy: ±3°F (2°C)

Resolution: ±1°F or °C

Setpoint Range: -15°F to 50°F (-26°C to 10°C)

Input Voltage: 10.5 to 28 VAC, 50/60 Hz or 12 to 28 VDC

Power Consumption: 5 VA max at 28 VAC

Operating Temperature Range: 0°C to 65°C

Output Relay: Form A relay contact, 1 A max. at 30 VAC or DC

Temperature Probe: NTC thermistor, 3000 ohms at 25°C, J-Curve



ORDERING INFORMATION

MOUNTING CONFIGURATION	PART NUMBER
Customer Panel Cutout	TNC-TM165-010
Standard Utility Box	TNC-TM166-010
Surface Mount Enclosure for TM165 Only, Single	TNC-TM165-KTA
Surface Mount Enclosure for TM165 Only, Dual	TNC-TM165-KT2A

ACCESSORY	PART NUMBER
6' Refrigerator / Freezer Probe	ASP-TM165-011
20' Refrigerator / Freezer Probe	ASP-TM165-012
60' Refrigerator / Freezer Probe	ASP-TM165-013
Transformer (UL Class II Secondary)	B10-NO120-011
Stainless Steel Enclosure for TNC-TM165-010 Only, Single	BOX-TM100-010
Stainless Steel Enclosure for TNC-TM165-010 Only, Dual	BOX-TM100-020

The TM165 and TM166 panel mount digital thermometers are available in two distinct sizes. When ordering the thermometers, be sure to select the above depending on your specific application (refer to actual dimensions at right).

Note: The TM165 can be used as a substitute for the TM100 in certain applications.

Model TM165

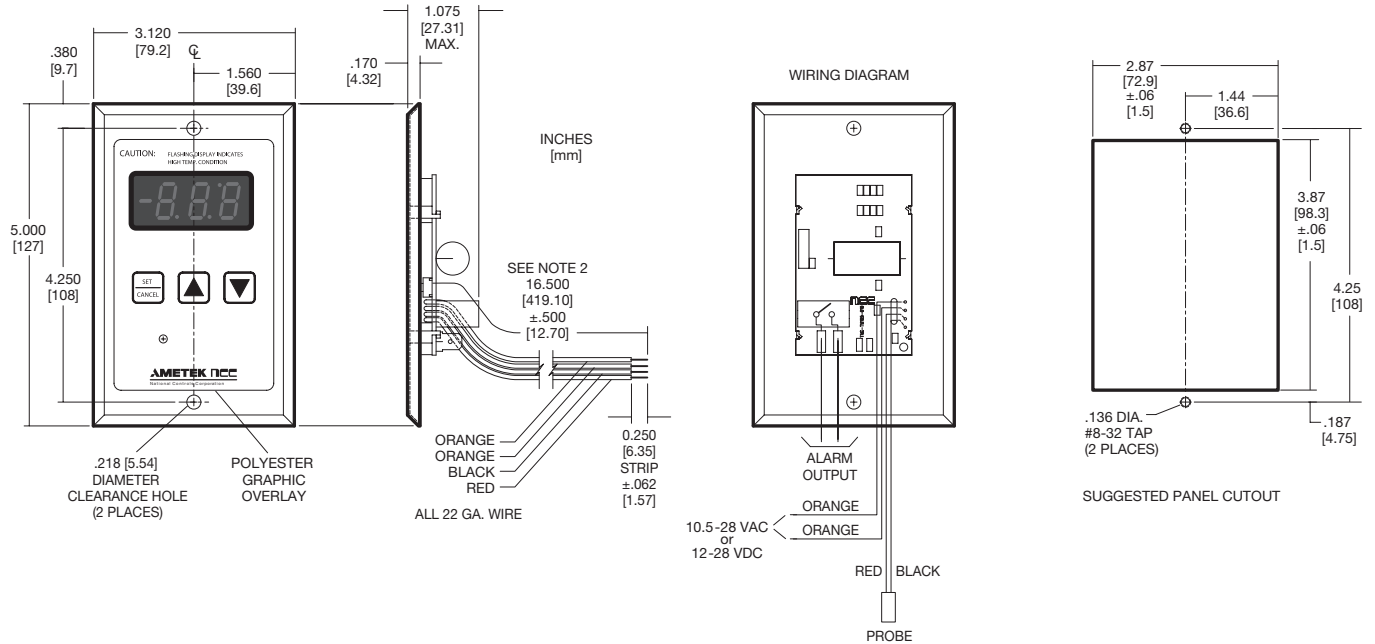

Model TM166

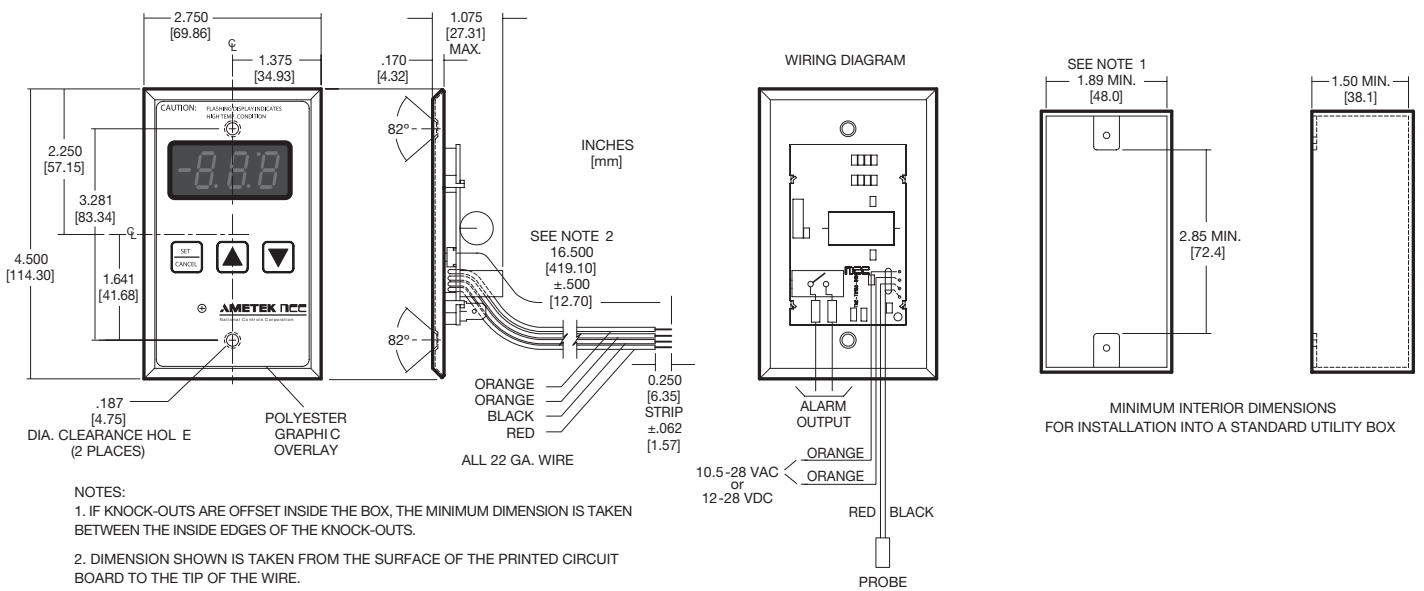

Digital Temperature Indicator

TM110 Series

FEATURES

- Compact design
- Easy-to-read red LED digital display
- Wide temperature sensing range
- Available in °F and °C

This series of temperature indicators provides a reliable, cost efficient way to monitor temperature in critical environments and equipment. This indicator can be used on-site or remotely, up to 250 feet from the probe.

This compact solid state unit features a large easy-to-read digital display, with a sensing range of -40°F to 240°F (-40°C to 115°C) and a calibration set-screw. Accessories include probes, compression fittings and transformer. Mounting is by four corner standoffs. Connections are made with two probe wires and two input voltage wires.

SPECIFICATIONS

INPUT

Operating Voltage: 12 to 28 VAC or VDC at 250 mA

Frequency: 50/60 Hz

Resolution: ±1°F (±1°C)

Temperature Reading Accuracy: ±2°F (±2°C) within ±50°F (±30°C) around temperature calibration point

Temperature Reading Range: -40°F (-40°C) to 240°F (115°C)

Ambient Temperature Range: 18°C to 60°C

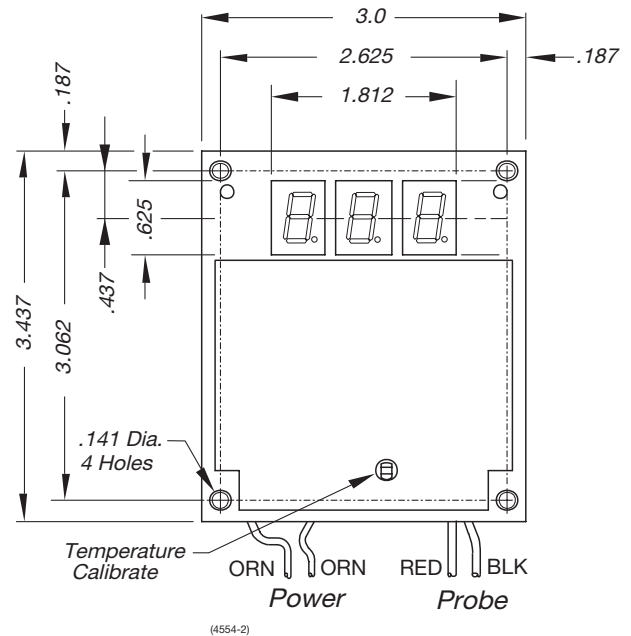

ORDERING INFORMATION

TEMPERATURE RANGE	PART NUMBER
°F Display	TNC-TM110-A10
°C Display	TNC-TM110-A10C

ACCESSORY	PART NUMBER
Refrigerator / Freezer Probe	ASP-TM100-011
Immersion Probe / Stainless Steel	ASP-TM100-012
20' Refrigerator / Freezer Probe	ASP-TM100-014
60' Refrigerator / Freezer Probe	ASP-TM100-015
Compression Fitting For ASP-TM100-012	EST-03/16-011
Transformer (120V input - 12V, 5VA output)	B10-NO120-011

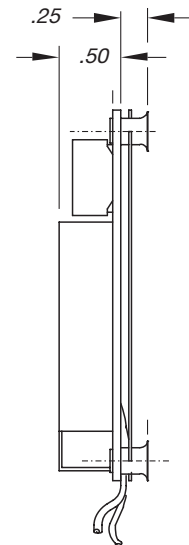

Note: The factory can match probe with indicator and calibrate as a set.



Digital Temperature Indicator

TM200 Series

FEATURES

- Compact design, will fit into 2" x 4" utility box
- Easy-to-read led digital display
- 120 VAC input voltage
- Easy field wiring
- Stainless steel front panel
- Withstands exposure to animal fats and cleaning agents found in restaurant environments
- Provides diagnostic messages for probe fault conditions
- Smooth, easy-to-clean front decal
- Available in °F and °C
-   File #E104595

This series of temperature indicators provides a reliable, cost efficient way to monitor temperature in a variety of environments and equipment.

These units feature a large red LED display with a sensing range of -40°F to 99°F or °C, and come with a stainless steel escutcheon front plate that mounts directly into a 2" x 4" utility box. To simplify the wiring, the units accept 120 VAC input directly.

SPECIFICATIONS

INPUT

Operating Voltage: 105 to 135 VAC at 50 mA

Frequency: 50/60 Hz

Resolution: ±1°F

Display Accuracy: ±2°F within ±50°F around known temperature calibration point. Full range accuracy ±5°F

Sensing Temperature Range: -40°F to 99°F or °C

Ambient Temperature Range: 0°C to 65°C

PROBE ERROR INDICATION

Shorted Probe: 2 decimal points only displayed

Open Probe: Negative sign and 2 decimal points only displayed

Out-of-Range Sense Temperature: 2 decimal points on with digits displayed

MECHANICAL

Mounting: Two faceplate screws (#6-32 x 1/2)

Front Panel Material: 18 gauge stainless steel

Decal Material: Polyester

Digit Height: .56 inches

Note: Due to non-interchangability of probes, the temperature indicator must be field calibrated using crushed ice and water and set to 32°F or 0°C

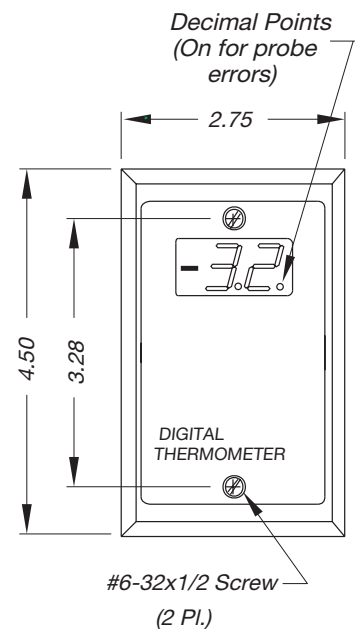

ORDERING INFORMATION

TEMPERATURE RANGE		PART NUMBER
°F Display		TNC-TM200-120
°C Display		TNC-TM200-120C
ACCESSORY		PART NUMBER
Refrigerator / Freezer Probe		ASP-TM100-011
Immersion Probe / Stainless Steel		ASP-TM100-012
20' Refrigerator / Freezer Probe		ASP-TM100-014
60' Refrigerator / Freezer Probe		ASP-TM100-015
2" x 4" Utility Box		BOX-02/04-ELECT

Note: The factory can match probe with indicator and calibrate as a set.

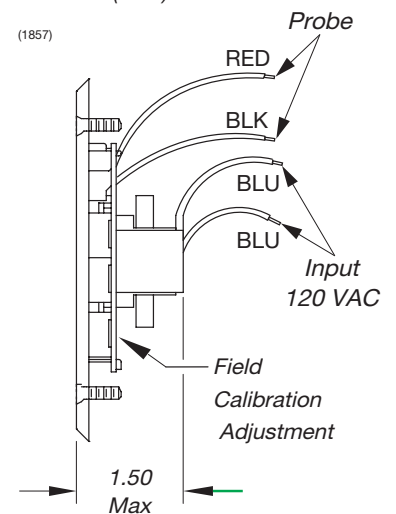

Electronic Temperature Controller

TC280 Series

FEATURES

- File #E104595
- Long term setpoint stability
- Close temperature control
- Footprint compatible with electro-mechanical thermostats
- OFF setpoint adjustment position
- Probe failure detect
- High current rating
- Long contact life

This Controller provides a reliable, cost effective way to control temperature of heated water within a limited temperature range.

Operating Logic: Upon application of input voltage, and if the sensed temperature is below the setpoint, the internal relay will be activated, turning on the heater load. The load will stay activated until the sensed temperature reaches setpoint value. The setpoint adjustment at the fully counter clockwise position has an OFF setting that can be used during equipment set-up to allow water to fill the vessel before allowing the heaters to be activated.

Note: The temperature adjustment OFF position is not a mechanical OFF condition, in case of controller failure it may not turn off the heater load.

SPECIFICATIONS

CONTROL

Temperature Control Mode: ON/OFF, +2°F to +4°F hysteresis

Temperature Sensor: Thermistor, ±2% interchangeable within measurement range

Set point Adjustment Range: 175°F ±5°F to 205°F +3°F/-1°F; Fully CCW is in OFF position

Probe Fault Detect: Open or shorted probe will cause output relay to be deactivated

INPUT

Power Consumption: 5 VA max.

Operating Voltage: 120, 220 VAC ±10%, 50/60 Hz

OUTPUT

Type: Relay contacts, SPST (1 Form A)

Rating: 20 A max. resistive at 120 VAC 10 A max. resistive at 250 VAC 100 mA at 5 VDC min. load current

Life: 250,000 cycles min. at full load

Dielectric Breakdown: 2500 VAC RMS, between probe terminals and input terminals

MECHANICAL

Termination: L1 and HTR #8 screw with clamp; L2 white -12" long - 22 AWG wire terminated with 1/4 inch female and 1/4" male piggy back push-on terminal

Probe: Screw type caged terminal block

ENVIRONMENTAL

Ambient Operating Range: 0°C to 60°C

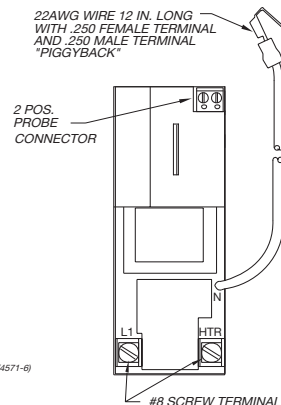
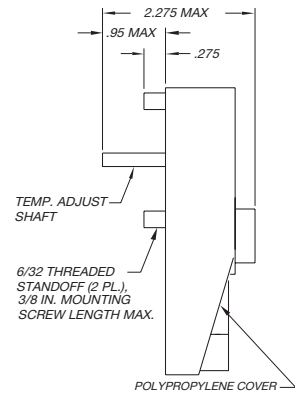
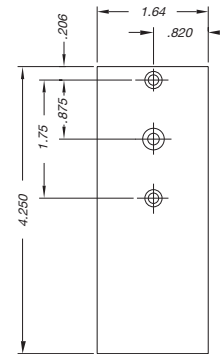
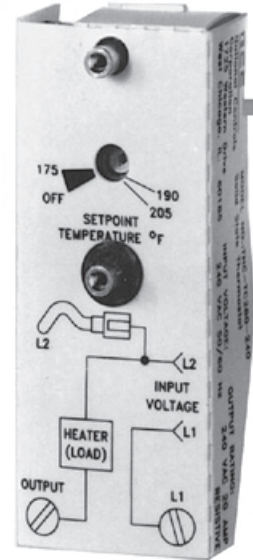

ORDERING INFORMATION

INPUT	PART NUMBER
120 V	TNC-TC280-120
240 V	TNC-TC280-240

ACCESSORY	PART NUMBER
12" Probe Tube	ASP-TC280-012
14" Probe Tube	ASP-TC280-014

Important Notice: This control should only be used in a system incorporating an independently operating high temperature limiting device which will safely disable the heaters, preventing property damage or bodily injury, in the event of failure, malfunction or normal wear-out of this control.

Transformers

ORDERING INFORMATION

120 to 10 VAC, 5 VA, 50/60 Hz	B10-NO120-011
120 to 12 VAC, 5 VA, 50/60 Hz	B12-NO120-015
120 to 24 VAC, 5 VA, 50/60 Hz	B24-NO120-011
240 to 24 VAC, 10 VA, 50/60 Hz	B24-NO220-011

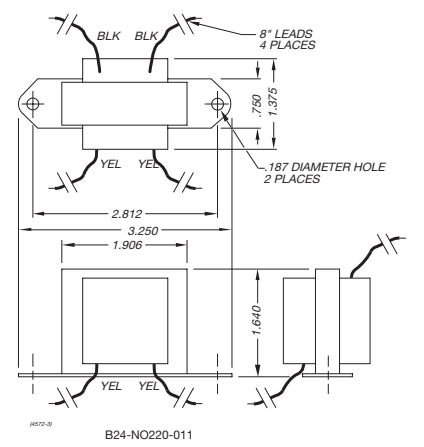
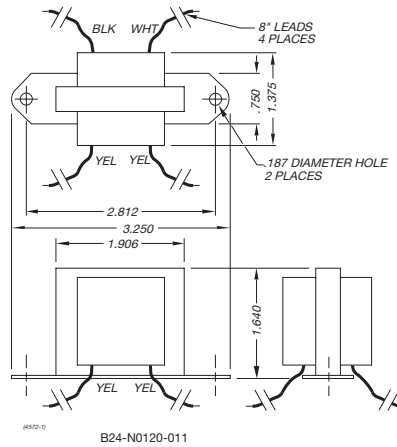
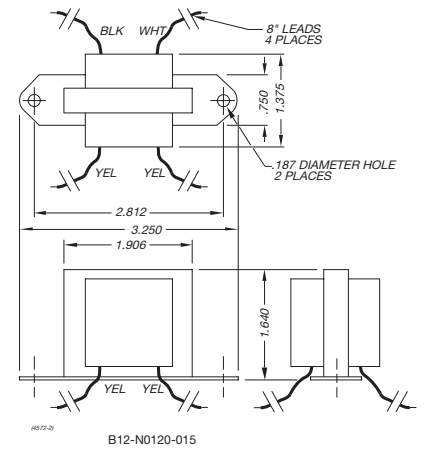
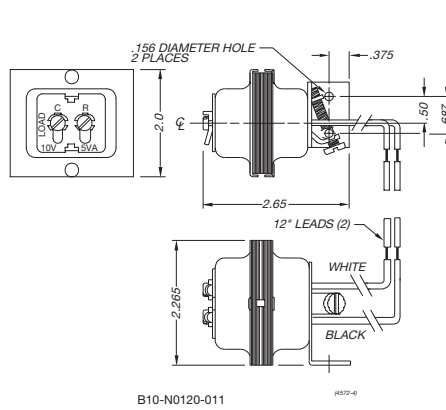

Probes

The temperature probes listed can only be used on TNC-TM100 (discontinued), TNC-TM110, and TNC-TM200 Series temperature indicators.

ORDERING INFORMATION

Refrigerator / Freezer Probe	ASP-TM100-011
Immersion Probe / Stainless Steel	ASP-TM100-012
20' Refrigerator / Freezer Probe	ASP-TM100-014
60' Refrigerator / Freezer Probe	ASP-TM100-015
Compression Fitting for ASP-TM100-012	EST-03/16-011

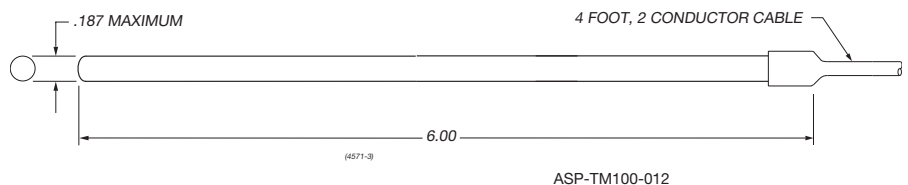
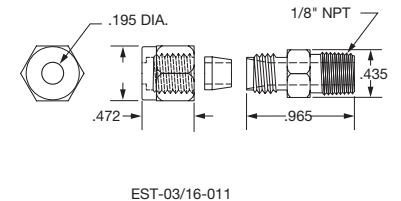
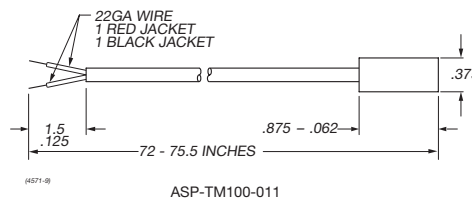

Boxes

ORDERING INFORMATION

Stainless Steel Box for One TM165	BOX-TM100-010
Stainless Steel Box for Two TM165s	BOX-TM100-020

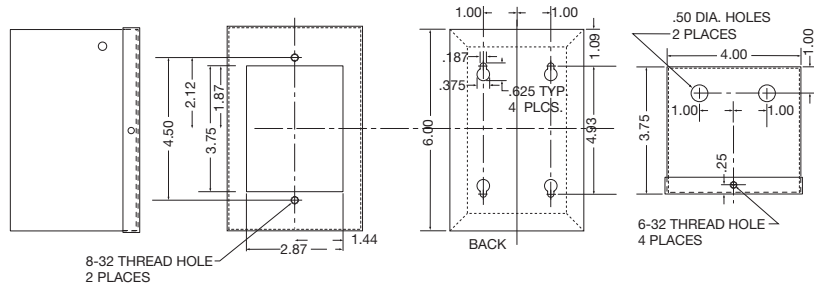

BOX-TM100-010

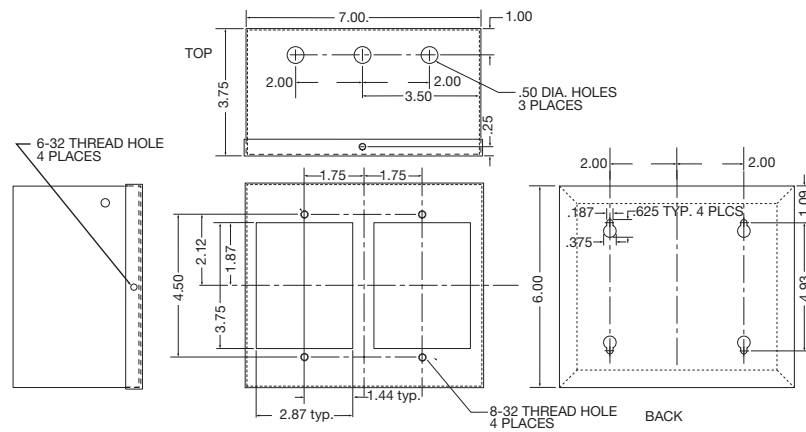

BOX-TM100-020

Transducers

The temperature transducers listed can only be used on TNC-TC280 Series temperature controllers.

ORDERING INFORMATION

Temperature Transducer, 8" Stainless Steel	ASP-TC280-011
Temperature Transducer, 12" Stainless Steel	ASP-TC280-012

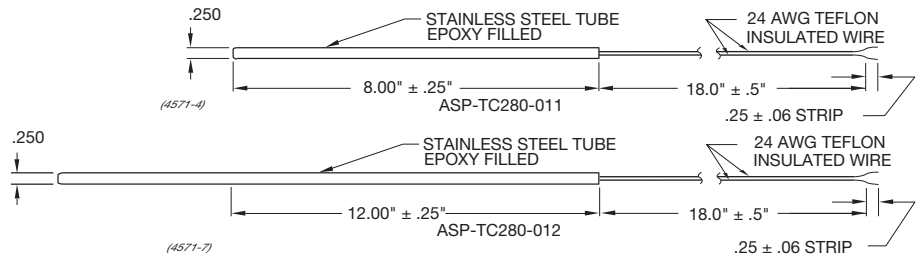

Thermocouples

The Type K thermocouple probes listed can only be used on TNC-TC140, and TNC-TC142 Series temperature controllers.

ORDERING INFORMATION

Type K Thermocouple, Bead Tip Probe, 6'	ASP-CH/AL-011
Type K Thermocouple, Perforated Probe, 24"	ASP-CH/AL-013
Type K Thermocouple, Probe with 6' Lead	ASP-CH/AL-016
Type K Thermocouple, Probe with 10' Lead	ASP-CH/AL-017
Type K Thermocouple, Perforated Probe, 48"	ASP-CH/AL-018
Type K Thermocouple, Perforated Probe, 72"	ASP-CH/AL-019
Type K Thermocouple, Probe with Flange	ASP-CH/AL-020
Type K Thermocouple, Ring Lug Mount	ASP-CH/AL-021

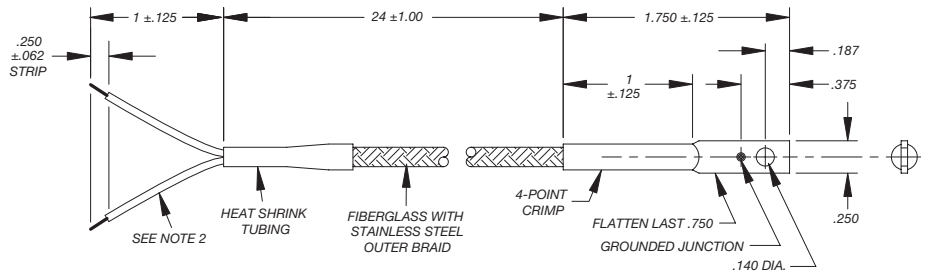
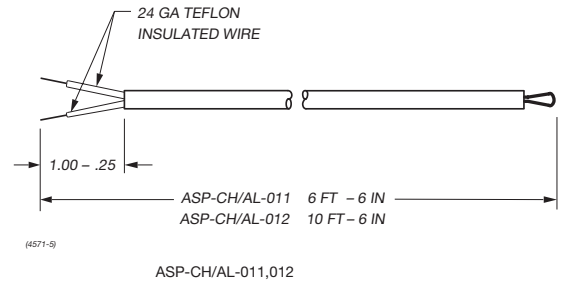

NOTES:

1. TEMPERATURE RATING TO 650°F
2. TYPE K THERMOCOUPLE, 24 GA. SOLID WIRE, FIBERGLASS INSULATED, SPECIAL LIMITS OF ERROR ±2°F OR .4% WHICHEVER IS GREATER.
3. ALL DIMENSIONS IN INCHES.
4. REMOVE SHARP EDGES.

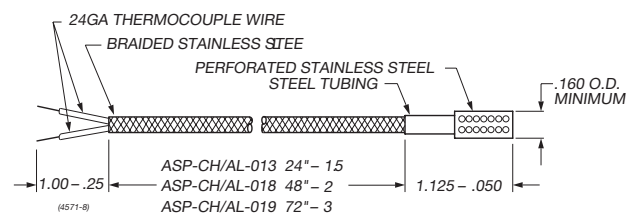
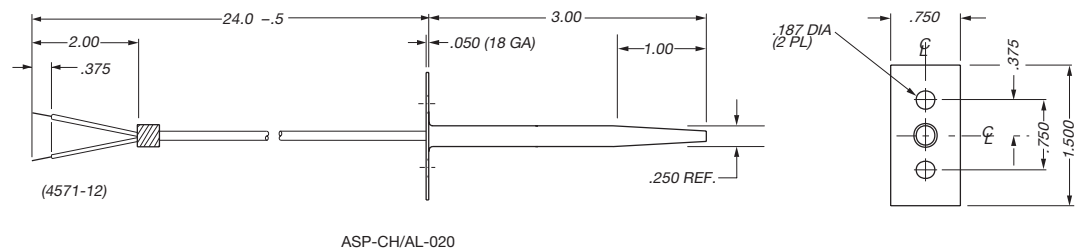
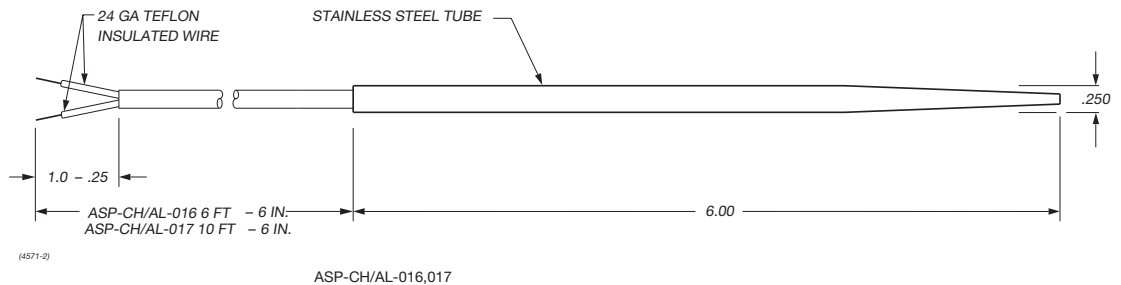

ASP-CH/AL-013,018,019



AMETEK NCC Dust Collector Controls offer sequential control of solenoid valves for pulse or shaker-damper cleaning of dust collectors. They are also used for display lighting, intermittent valve or sequential control.

AMETEK NCC offers impressive factory back-up support. Our parts inventory and product availability is unsurpassed. With over 250 stocking distributor outlets, serious downtime problems can virtually be eliminated. Technical assistance for design and engineering help is readily available through our **toll free number: 800-323-2593.**

Common Applications:

- *Process Control*
- *Stepping Switch Programming*
- *Solenoid Valve Sequencing*
- *Vacuum Processing*
- *Bottle Filling*
- *Plastic Molding*
- *Vending Machines*
- *Printing Presses*
- *Laundry Equipment*
- *Textile Machinery*
- *Machine Tools*
- *Test Cycling*
- *Food Processing*
- *Water Purification*
- *Copying Machines*
- *Alarm Circuits*
- *Pulse Totalizing*
- *Heat Sealing*
- *Photo Processing*
- *Car Washing*
- *Engine Starting*
- *X-Ray Equipment*
- *Ventilator Controls*

Intermittent Use Collectors

Model T2101

FEATURES

- Simple 4 wire installation
- Replaces electromechanical timers
- Completely solid state timing and switching logic
- High quality locking bushing potentiometers for timing adjustment
- Very low power consumption
- Conformally coated for protection against vibration, humidity, and contamination
- LED function lights on PC board
- Function indicating lights on T2101-020
- Mounts in standard NEMA 4/JIC enclosures
-   File #E65038

LOGIC FUNCTION DIAGRAM

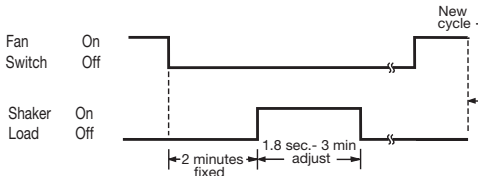

Operating Logic: The control is used on intermittent type dust collectors to automatically activate the shaking mechanism 2 minutes after the fan motor is turned off.

Upon removing power from the fan, a 2 minute fixed delay is initiated. At the end of the delay, the shaker output is activated for an adjustable period of 1.8 seconds to 3 minutes. Resetting the control occurs by turning the fan motor on again.

CAUTION: The control must be wired according to the schematic provided.

SPECIFICATIONS

TIMING

Delay Time: 120 sec. $\pm 10\%$ fixed

Shake Time: Adjustable from 1.8 to 180 sec.

Repeatability: $\pm 3\%$ over temperature and voltage range

INPUT

Operating Voltage: 105 to 135 VAC

Power Consumption: 5.5 W plus shaker contactor coil power

Frequency: 50/60 Hz

OUTPUT

Type: Solid state switch, 1 A continuous at 1.5 V below input voltage

TRANSIENT PROTECTION

Input: Transformer and large filter capacity

Output: Solid state switch rated for 10 A at 400V protected by metal oxide varistor; 3 A fuse protects against external short circuit

ENVIRONMENTAL

Operating Temperature: -40°C to 65°C

Storage Temperature: -40°C to 70°C

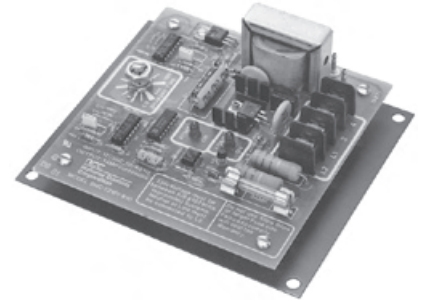

ORDERING INFORMATION

DESCRIPTION	PART NUMBER
Control on Chassis	DNC-T2101-010
Control in Hinged NEMA 4 Box with Functional Lights	DNC-T2101-020

ACCESSORY	DIMENSIONS	PART NUMBER
NEMA 4 Box	6" x 8" x 4"	BOX-A0606-CHNF
Pilot Lamp	NEMA 4 Rated Red Light	ASL-00RED-NEMA 4
On/Off Switch	NEMA 4 Rated with Legend Plate	MSW-0DPST-011

AMETEK NCC offers NEMA 4 type enclosures for mounting our controls. These enclosures are made of heavy gauge steel and have a continuous hinge cover. All seams are continuously welded. The finish is gray hammer-tone enamel inside and out, over phosphatized surfaces.

Caution:

1. Do not mount controls in high vibration areas without shock mounts.
2. Do not mount controls in areas of high dust or corrosive atmospheres without a protective enclosure.
3. Do not use a converter or inverter for the power source.
4. Do not mount control in high transient voltage areas without an isolation transformer
5. Do not leave control box open.
6. Do not allow a local repair shop to repair the controls, as we employ some very sophisticated components that could be further damaged. For service, call us directly: 800-323-2593

Model DNC-2101-010

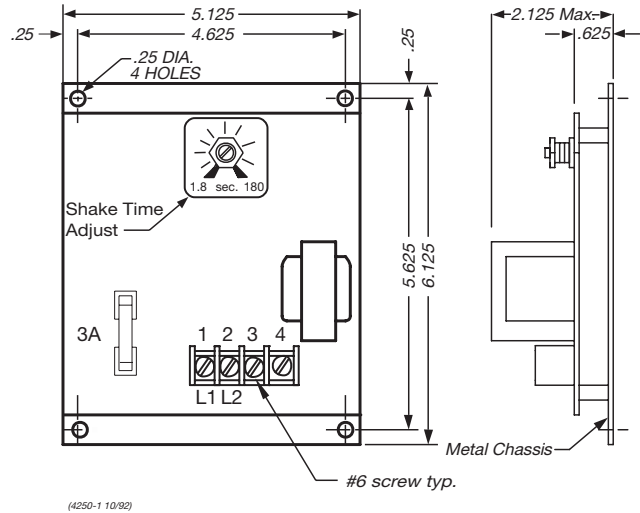

Model DNC-2101-020

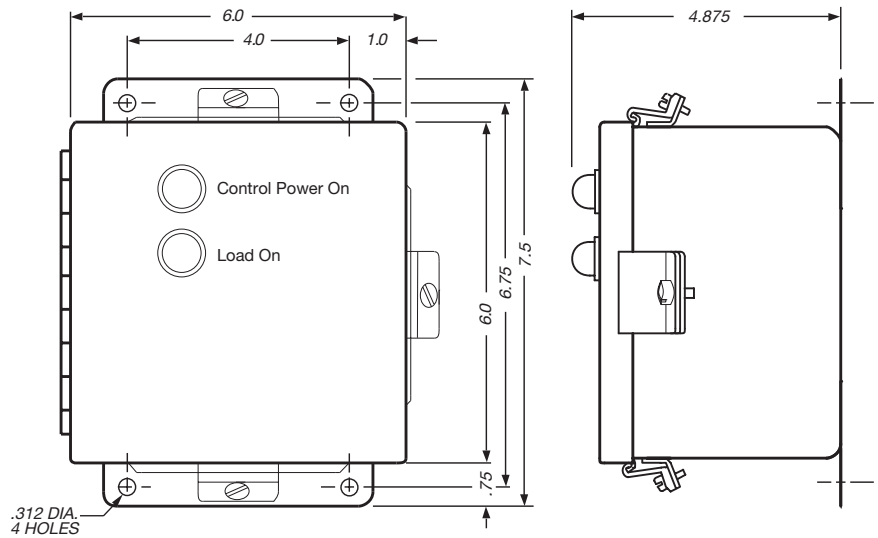

Field Wiring Diagram

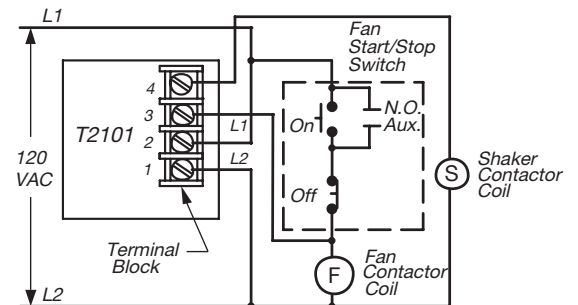

4-4 DUST COLLECTOR CONTROLS

AC Input, Pulse Cleaning of Bag House Dust Collectors

Models DNC-T2003 through DNC-T2032

FEATURES

- **Digital Timing Circuitry:** allows for stable timing from -40°C to 65°C temperature range
- **Pulse Time:** line synchronized to eliminate 8 millisecond triac turn off variation
- **10 A-400/600V Output Triacs:** for maximum protection against output shorts. 200 VA load rating
- **Conformally coated for protection against vibration, humidity, and contamination**
- **2 Modes of Operation:** can be operated Continuously or On Demand via external pressure switch
- **Field Selectable:** for numbers of outputs required
- **LED Indicators:** for compartment being cleaned indication
- **Rugged Timing Adjustments:** large stable potentiometers are used for ON and OFF time adjustments
- **Metal Chassis Provided:** for mounting directly into NEMA 4 box
- **Timer Functionally Tested for 24 Hours:** to eliminate field failures
- **Input Protection:** 30 joule metal oxide varistor
- **One Year Warranty:** warranted to be free from defects in materials or workmanship for one year from date of manufacture
-  File #E65038

Operating Logic: The control can function in 2 modes.

In Continuous Mode, the pressure switch terminals are shorted. Upon application of input voltage, the control activates output #1 after the preset off time. It will continue to activate outputs sequentially until input voltage is removed.

In On Demand Mode, the pressure switch terminals are connected to an isolated set of contacts of a differential pressure switch. The control will activate the outputs sequentially whenever the pressure switch contacts are closed. When the pressure switch contacts open, the output sequencing stops. Re-closing of the contacts will cause the control to resume activating the outputs.

Program wire allows the user to select the maximum number of outputs to be activated.

Note: Controls are shipped with jumper across pressure switch terminals

SPECIFICATIONS

TIME DELAY

ON-Time: Adjustable from 50 to 500 ms

OFF-Time:

Range A: adjustable from 1.5 to 30 seconds

Range B: adjustable from 8.5 to 180 seconds

Note: Range S designates customer specified time range. Consult factory for parameters

Repeatability: ±3% over temperature and voltage ranges

INPUT

Operating Voltage: 120 ±10%, 220 ±10% VAC

Frequency: 50/60 Hz

Power Consumption: 2 VA max.

OUTPUT

Type: Solid state switch (triac)

Switch Rating: 200 VA maximum per output

PROTECTION

Transient Voltage: 30 joule metal oxide varistor

Short Circuit Protection: 3 A fuse

ENVIRONMENTAL

Operating Temperature: -40°C to 65°C

Storage Temperature: -40°C to 70°C

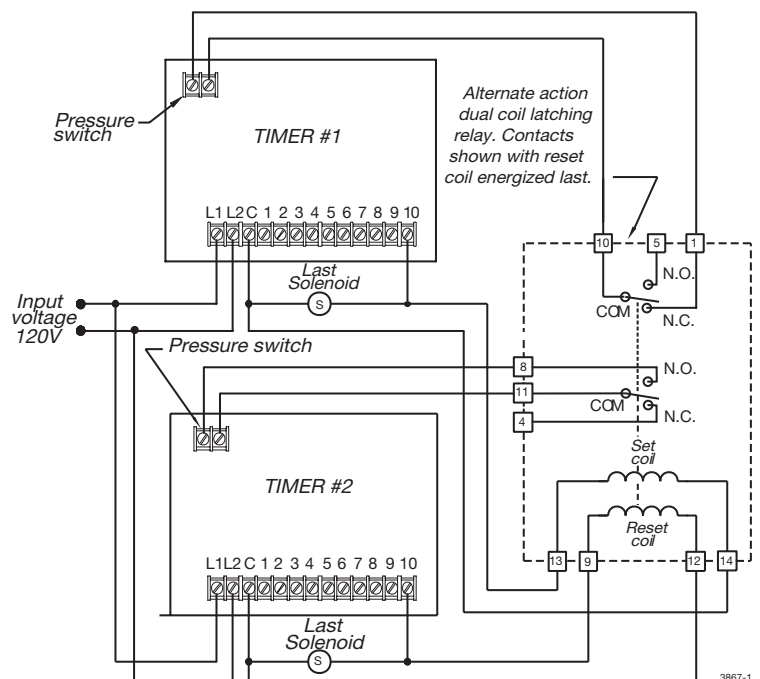
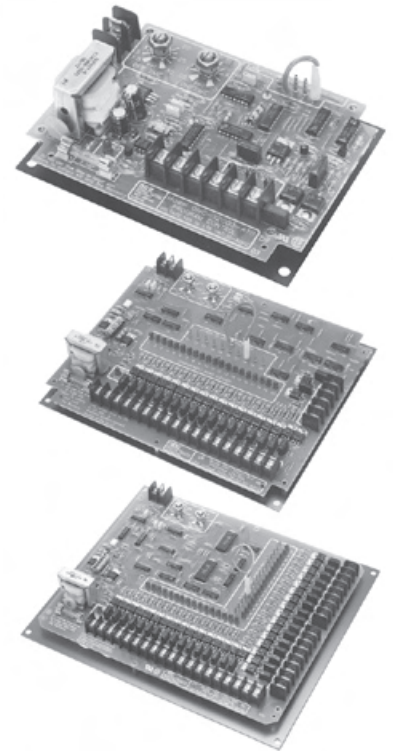

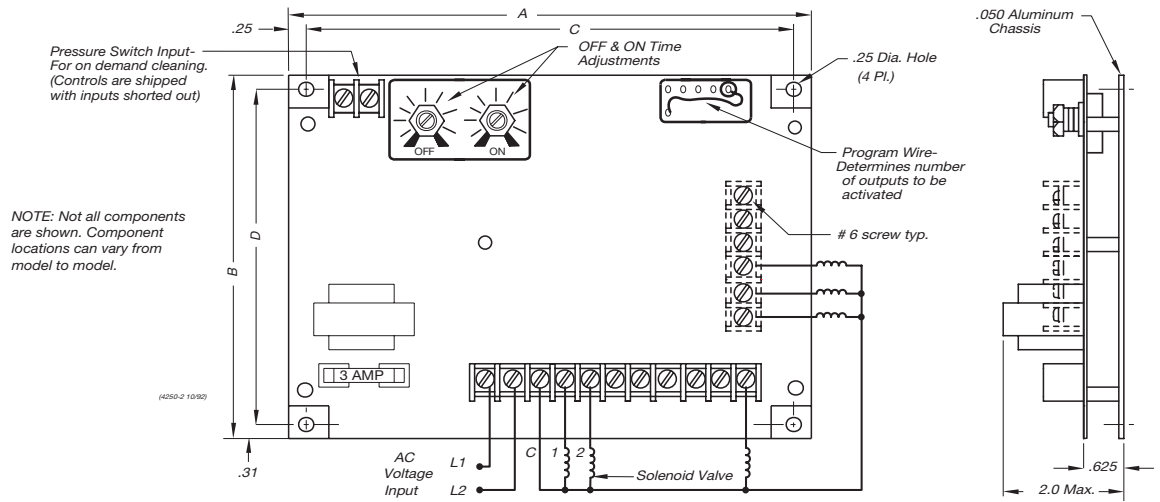

ORDERING INFORMATION

MAX. NO. OF OUTPUTS	DIMENSIONS				SIZE OF NEMA 4 ENCLS. REQUIRED	PROGRAM-MABLE NO. OF OUTPUTS	OFF TIME	PART NUMBER
	A	B	C	D				
DNC-T2003 THROUGH DNC-T2032 120 VAC INPUT VOLTAGE								
3	6.75	4.875	6.25	4.25	8" x 6" x 3.5"	1-3	1.5 to 30 sec.	DNC-T2003-A10
							8.5 to 180 sec.	DNC-T2003-B10
6	8.75	6.875	8.25	6.25	10" x 8" x 4"	2-6	1.5 to 30 sec.	DNC-T2006-A10
							8.5 to 180 sec.	DNC-T2006-B10
10	8.75	6.875	8.25	6.25	10" x 8" x 4"	3-10	1.5 to 30 sec.	DNC-T2010-A10
							8.5 to 180 sec.	DNC-T2010-B10
20	10.75	8.875	10.25	8.25	12" x 10" x 5"	11-20	1.5 to 30 sec.	DNC-T2020-A10
							8.5 to 180 sec.	DNC-T2020-B10
32	12.75	10.875	12.25	10.25	14" x 12" x 6"	17-32	1.5 to 30 sec.	DNC-T2032-A10
							8.5 to 180 sec.	DNC-T2032-B10
DNC-T2006 THROUGH DNC-T2032 220 VAC INPUT VOLTAGE								
6	8.75	6.875	8.25	6.25	10" x 8" x 4"	2-6	1.5 to 30 sec.	DNC-T2006-A220
							8.5 to 180 sec.	DNC-T2006-B220
10	8.75	6.875	8.25	6.25	10" x 8" x 4"	3-10	1.5 to 30 sec.	DNC-T2010-A220
							8.5 to 180 sec.	DNC-T2010-B220
20	10.75	8.875	10.25	8.25	12" x 10" x 5"	11-20	1.5 to 30 sec.	DNC-T2020-A220
							8.5 to 180 sec.	DNC-T2020-B220
32	12.75	10.875	12.25	10.25	14" x 12" x 6"	17-32	1.5 to 30 sec.	DNC-T2032-A220
							8.5 to 180 sec.	DNC-T2032-B220

Note: Special time ranges are available with the following maximum to minimum time ratio restrictions: ON Time-10:1; OFF Time-20:1

ACCESSORY	DIMENSIONS	PART NUMBER
Enclosure for DNC-T2003	8" x 6" x 3.5"	BOX-A0806-CHNF
Enclosure for DNC-T2006	10" x 8" x 4"	BOX-A1008-CHNF
Enclosure for DNC-T2010	10" x 8" x 4"	BOX-A1008-CHNF
Enclosure for DNC-T2020	12" x 10" x 5"	BOX-A1210-CHNF
Enclosure for DNC-T2032	14" x 12" x 6"	BOX-A1412-CHNF

ACCESSORY	DIMENSIONS	PART NUMBER
Pilot Lamp	NEMA 4 Rated Red Light	ASL-00RED-NEMA-4
On/Off Switch	NEMA 4 Rated with Legend Plate	MSW-0DPST-001
Alternate Action Dual Coil Latch Relay	—	KDD-LATCH-120AC
Socket For Latch Relay	—	MSO-0D11P-012

AMETEK NCC offers NEMA 4 type enclosures for mounting our controls. These enclosures are made of heavy gauge steel and have a continuous hinge cover. All seams are continuously welded. The finish is gray hammer-tone enamel inside and out, over phosphatized surfaces.

Caution:

1. Do not mount controls in high vibration areas without shock mounts.
2. Do not mount controls in areas of high dust or corrosive atmospheres without a protective enclosure.
3. Do not use a converter or inverter for the power source.
4. Do not mount control in high transient voltage areas without an isolation transformer.
5. Do not leave control box open.
6. Do not allow a local repair shop to repair the controls, as we employ some very sophisticated components that could be further damaged. For service, call us directly: 800-323-2593.

DC Input, Pulse Cleaning of Bag House Dust Collectors

Model DNC-T2010-ADC

FEATURES

- Field selectable from 2 to 10 outputs
- Solid state timing and switching logic
- 300% overrated solid state switch
- Pressure switch control option on board
- 12 to 24 VDC input voltage
- Adjustable ON and OFF times
- High quality locking bushing potentiometers for timing adjustment
- Very low power consumption
- Conformally coated for protection against vibration, humidity, and contamination
- LEDs show compartment being cleaned
- Metal chassis provided for mounting directly into NEMA 4 enclosure

Operating Logic: The control can function in 2 modes.

In Continuous Mode, the pressure switch terminals are shorted. Upon application of output voltage, the control activates output #1 after the preset off time. It will continue to activate outputs sequentially until input voltage is removed.

In On Demand Mode, the pressure switch terminals are connected to an isolated set of contacts of a differential pressure switch. The control will activate the outputs sequentially whenever the pressure switch contacts are closed. When the pressure switch contacts open, the output sequencing stops. Re-closing of the contacts will cause the control to resume activating the outputs. Program wire allows the user to select the maximum number of outputs to be activated.

Note: Controls are shipped with jumper across pressure switch terminals.

SPECIFICATIONS

TIME SETTING RANGES

ON-Time: Adjustable from 20 to 200 ms

OFF-Time: Adjustable from 1.5 to 60 sec.

Repeatability: $\pm 3\%$ over temperature and voltage ranges

INPUT

Operating Voltage: 10.0 to 29.0 VDC (unfiltered supply voltage must be full-wave rectified)

Power Consumption Voltage During Off Time: 1.5 W at 12 VDC, 4.2 W at 24 VDC

OUTPUT

Type: Solid state switch

Load Per Output: 3 A max. at 1.5 V less than input voltage

PROTECTION

Transient Input Voltage: Metal oxide varistor plus large filter capacity

Transient Output Voltage: Solid state switch rated at 10 A to 60 V fly-back diode protected

Short Circuit Protection: 3 A fuse for circuit, reverse polarity protected

ENVIRONMENTAL

Operating Temperature: -40°F to 150°F (-40°C to 65°C)

Storage Temperature: -40°F to 185°F (-40°C to 85°C)

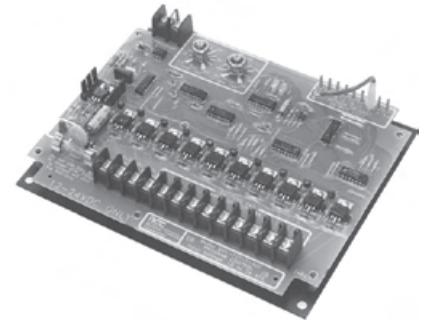

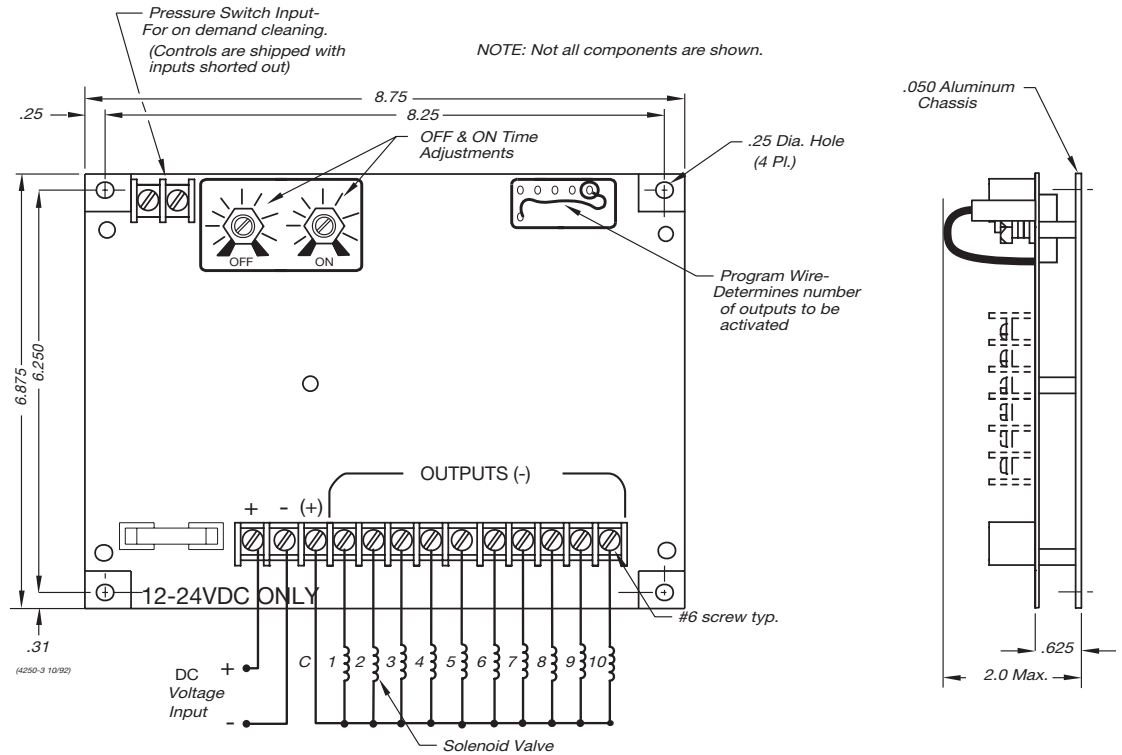

ORDERING INFORMATION

PROGRAMMABLE NO. OF OUTPUTS	INPUT VOLTAGE	OFF TIME	PART NUMBER
2 to 10	12 to 24 VDC	1.5 to 60 sec.	DNC-T2010-ADC

ACCESSORY	DIMENSIONS	PART NUMBER
NEMA 4 Box	10" x 8" x 4"	BOX-A1008-CHNF
NEMA 4 Box	12" x 10" x 5"	BOX-A1210-CHNF
ON/OFF Switch	NEMA 4 Rated with Legend Plate	MSW-0DPST-011

AMETEK NCC offers NEMA 4 type enclosures for mounting our controls. These enclosures are made of heavy gauge steel and have a continuous hinge cover. All seams are continuously welded. The finish is gray hammer-tone enamel inside and out, over phosphatized surfaces.

Caution:

1. Do not mount controls in high vibration areas without shock mounts.
2. Do not mount controls in areas of high dust or corrosive atmospheres without a protective enclosure.
3. Do not use a converter or inverter for the power source.
4. Do not mount control in high transient voltage areas without an isolation transformer.
5. Do not leave control box open.
6. Do not allow a local repair shop to repair the controls, as we employ some very sophisticated components that could be further damaged. For service, call us directly: 800-323-2593.

Pulse Jet Dust Collector Control with Extended Cycle

DNC-T2110 Series

FEATURES

- **Digital Timing Circuitry:** allows for stable timing from -40°C to 65°C temperature range
- **Pulse Time:** line synchronized to eliminate 8 millisecond triac turn off variation
- **10 A-400/600V Output Triacs:** for maximum protection against output shorts; 200 VA load rating
- **Conformally coated for protection against vibration, humidity, and contamination**
- **2 Modes of Operation:** can be operated Continuously or On Demand via external pressure switch
- **Extended cycle capability for added pulses after pressure switch opens**
- **Field Selectable:** for numbers of outputs required
- **LED Indicators:** for compartment being cleaned indication
- **Rugged Timing Adjustments:** large stable potentiometers are used for ON and OFF time adjustments
- **Metal Chassis Provided:** for mounting directly into NEMA 4 box
- **Timer Functionally Tested:** to eliminate field failures
- **Input Protection:** 30 joule metal oxide varistor
- **One Year Warranty:** warranted to be free from defects in materials or workmanship for one year from date of manufacture

Operating Logic: The DNC-T2110-A10/B10 are ten output sequencer, cycle timers with adjustable ON-TIME, OFF-TIME and DELAY times. When voltage is applied to L1 and L2 and the pressure switch is closed, the OFF-TIME is started. At the end of the preset OFF-TIME the control will cycle through the outputs until the pressure switch opens. The ENABLE/DISABLE switch on the control can enable the OFF-DELAY. When the pressure switch opens and the OFF-DELAY is enabled, then the OFF-DELAY time is started and the OFF-TIME, ON-TIME cycles will continue until the end of the OFF DELAY time. If the OFF-DELAY times out during the ON-TIME, the control will allow the ON-TIME to time out. Upon closing of the pressure switch the control will commence the OFF-TIME, ON-TIME sequence on the next output and the OFF-DELAY time will reset. If the pressure switch is closed during the OFF-DELAY time, the control will reset the OFF-DELAY. The ENABLE/DISABLE switch on the control can disable the OFF-DELAY. When the OFF-DELAY is disabled and the pressure switch opens, during the ON-TIME, the control will allow the ON-TIME to time out. Upon closing of the pressure switch the control will commence the OFF-TIME, ON-TIME sequence on the next output.

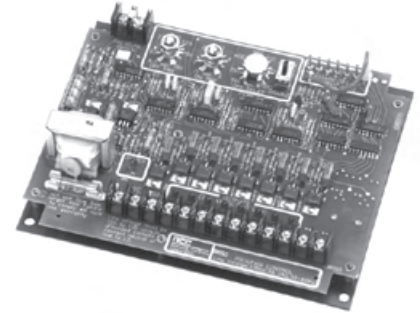

LOGIC FUNCTION DIAGRAM

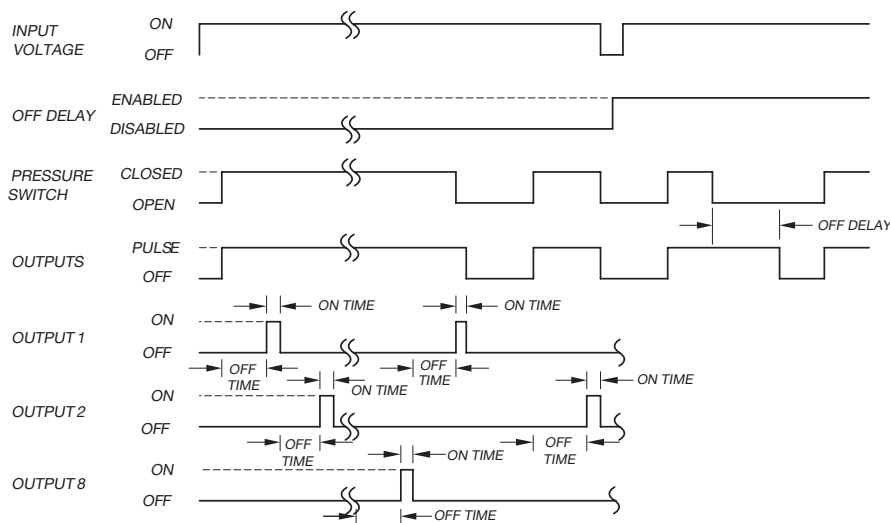

SPECIFICATIONS

TIME DELAY

OFF-Delay Time: Adjustable from 100 sec. +0%, -50% to 1000 sec. +10%, -0%. OFF Delay Time can be disabled

ON-Time: Adjustable from 50 to 500 ms

OFF-Time:

Range A: adjustable from 1.5 to 30 seconds
Range B: adjustable from 8.5 to 180 seconds

Repeatability: ±3% over temperature and voltage ranges

INPUT

Operating Voltage: 105 to 135 VAC

Frequency: 50/60 Hz

Power Consumption: 5 VA max.

OUTPUT

Type: Solid state switch (triac)

Switch Rating: 200 VA max. per output, 1.8 VAC

RMS max.; ON state voltage drop 4 mA max.;

OFF state leakage current at 120 VAC

PROTECTION

Transient Voltage: 30 joule metal oxide varistor

Short Circuit Protection: 3 A fuse

ENVIRONMENTAL

Operating Temperature: -40°C to 65°C

Storage Temperature: -40°C to 85°C

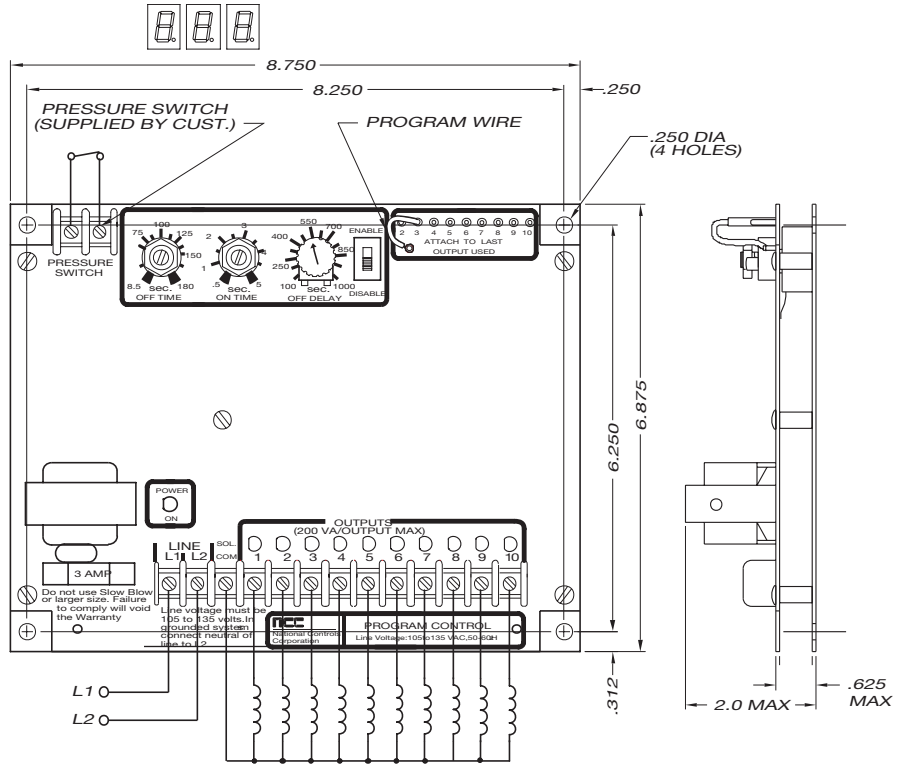

ORDERING INFORMATION

PROGRAMMABLE NO. OF OUTPUTS	OFF TIME	PART NUMBER
1 to 3	1.5 to 30 sec.	DNC-T2003-A10
	8.5 to 180 sec.	DNC-T2003-B10

ACCESSORY	DIMENSIONS	PART NUMBER
NEMA 4 Box	10" x 8" x 4"	BOX-A1008-CHNF
Pilot Lamp	NEMA 4 Rated Red Light	ASL-00RED-NEMA 4
On/Off Switch	NEMA 4 Rated with Legend Plate	MSW-ODPST-011

AMETEK NCC offers NEMA 4 type enclosures for mounting our controls. These enclosures are made of heavy gauge steel and have a continuous hinge cover. All seams are continuously welded. The finish is gray hammer-tone enamel inside and out, over phosphatized surfaces.

Caution:

1. Do not mount controls in high vibration areas without shock mounts.
2. Do not mount controls in areas of high dust or corrosive atmospheres without a protective enclosure.
3. Do not use a converter or inverter for the power source.
4. Do not mount control in high transient voltage areas without an isolation transformer.
5. Do not leave control box open.
6. Do not allow a local repair shop to repair the controls, as we employ some very sophisticated components that could be further damaged. For service, call us directly: 800-323-2593.

DUSTRONIX™ Core-10/Expander-10 Dust Collector Controls

Models DNC-T2610-010/020

FEATURES

- Communicates via 2 wire CANbus network
- Universal input voltage 100-240 VAC, 50/60 Hz
- 10 outputs on-board, expands to 990 outputs (with expansion boards)
- Solenoid current sense:
 - allows automatic system setup
 - senses 3 solenoids per output
 - monitor up to 2970 solenoids
- Diagnostic/program LEDs for “at-a-glance” system status indication
- Settable to read 0-10, 0-15, and 0-25 inches of differential pressure
- Finger-safe terminations

CORE-10 UNIQUE FEATURES

- Simple one knob programming
- Non-volatile memory for program and status storage
- On-Demand operation:
 - with external pressure switch (not included)
 - with external pressure sensor (not included)
 - source/sink 4 to 20 mA sensor input
- 3-digit, 7-segment alpha-numeric display
- Settable alarm output relay normally open or normally closed

The Core-10 is the main control module in the DUSTRONIX line. The Core-10 is capable of operating as a standalone module controlling 1 to 10 solenoids, or in combination with the Expander-10 for up to 98 expansion modules for a total of 990 outputs. The Expander-10 is the expansion output board in the DUSTRONIX family. The Expander-10 operates in combination with the Core-10 Control Module.

The Expander-10 communicates with the Core-10 on a twisted pair of wires using CANbus architecture which provides robust noise immunity. Two rotary switches on the Expander-10 are used to set and provide visual indication of the address assigned.

The Core-10 can operate in On-Demand mode with input from an external pressure sensor (4 to 20 mA) or a pressure switch (not included), or it can operate in the Continuous mode by use of a jumper across the pressure switch input. A switch can also be connected to the pressure switch input to act as a bypass switch. Input for a cycle down switch is also provided to allow for end-of-operation cleaning.

A unique feature of the Core-10 is its simple one-button programming. This single push-button/encoder is used to select operating parameters. LEDs indicate program function. The push-button is also used to view alarm conditions and cancel the alarm output. Operating and programming information is displayed on a 3-digit 7-segment display. The compact size of the Core-10 and the Expander-10 allows mounting in enclosures as small as 8" x 6".

Programmable Parameters:

- Solenoid ON-Time/OFF-Time
- Number of cycle down cycles
- Cycle down time delay
- Run/Standby: enable/disable outputs
- Differential pressure high setpoint/low setpoint
- Differential pressure high alarm setpoint/low alarm setpoint
- Alarm contact (normally open or normally closed)
- Differential Pressure Sensor Select: 10, 15, 25 in. w.c.
- Output: 1 to 990 manual or auto-configured

Status LEDs: when illuminated

- Differential Pressure: Display indicates ΔP



- **Output:** Display indicates current output
- **Alarm (System Status):** ΔP or Solenoid Fault
- **Output Pulsing:** Display indicates output being pulsed
- **Cycle Down:** Unit in cycle down mode
- **Output Status:** Unit pulsing solenoids
- **CANbus Status:** CANbus transmission activity

DUSTRONIX “Kit” Configurations

1. **DNC-T2610-N4A:** Includes Core-10, PS700, 3-position switch, NEMA 4 10"x8"x6" metal enclosure with cutouts, bulk-head fittings, mounting chassis, mounting
2. **DNC-T2610-N4XA:** Same as above but mounted in fiberglass enclosure
3. **DNC-T2610-N4B:** Same as Kit 1 but also includes Expander-10 module
4. **DNC-T2610-N4XB:** Same as Kit 3 but mounted in fiberglass enclosure

ORDERING INFORMATION

INPUT VOLTAGE	PART NUMBER
100 to 240 VAC	DNC-T2610-010
100 to 240 VAC	DNC-T2610-020

ACCESSORY	DIMENSIONS	PART NUMBER
Enclosure for DNC-T2610-010	10" x 8" x 6"	BOX-A1008-CHSC
		BOX-A1008-CHNF

SPECIFICATIONS

CORE-10

INPUTS

Supply: 100-240 VAC, 50/60Hz, 4 VA max. at 240VAC without loads

Fuse: 3A fast, 5x20 mm

Δ Pressure Sensor Input: 4 to 20 mA, sink/ source, programmable 10.0", 15.0", 25.0" w.c.

Δ Pressure Switch Input: Dry contact, 4 mA at 13 VDC max.

Cycle Down Switch Input: Dry contact, 4 mA at 13 VDC max.

OUTPUTS

Solenoid Outputs: 10

Output Type: Triac

Output Rating: 150 VA (at max. ON, min. OFF, 1 output selected)

Timing Accuracy: -2mS, +10 mS or ±1% (which ever is greater), ON-time synchronized to AC line

Alarm Relay: Form-A contact, 3A at 250 VAC/30 VDC, programmable normally open or normally closed

DISPLAY INDICATORS

3-digit 7-segment LED display, 0.56 in. red

Program Parameters/Display Status/CANbus Status: 17 green LEDs

Alarm: 1 red/yellow LED

Output Status: 1 red/green LED

PARAMETER RANGES

ON-Time: 0.050-600 sec.

OFF-Time: 1-999 sec.

Timing Accuracy: -2 ms, +10 ms or ±1% (which ever is greater), ON-time synchronized to AC line

Cycle Down Cycles: 1-20, none

Cycle Down Delay: 60-600 sec.

Δ P High Setpoint: 0-10/15/25" w.c., none

Δ P Low Setpoint: 0-10/15/25" w.c., none

Δ P High Alarm: 0-10/15/25" w.c., none

Δ P Low Alarm: 0-10/15/25" w.c., none

COMMUNICATIONS

Type: CANbus architecture

Terminations: Screw terminals, #12 to #28 AWG, finger safe

ENVIRONMENTAL

Operating Temperature: -40°F to +150°F (-40°C to +65°C)

Environmental Protection: Conformal coating for humidity and vibration

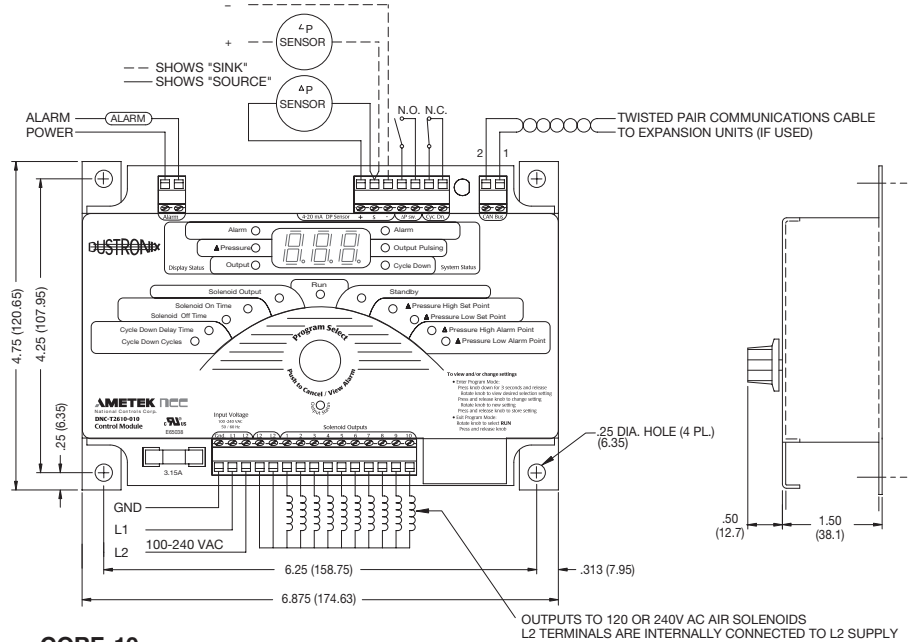

CORE-10

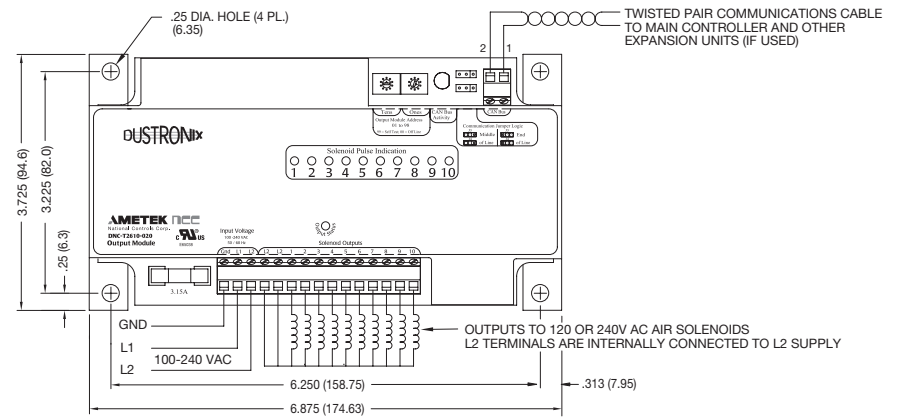

EXPANDER-10

EXPANDER-10 SPECIFICATIONS

INDICATORS

Solenoid Pulse Indication: 10 green LEDs

CANbus Status: 1 green LED

Output Status: 1 red/green LED

OUTPUTS

Solenoids: 10 per Expansion Module

Output Type: Triac

Output Rating: 150 VA (at max. ON, min. OFF, 1 output selected)

Timing Accuracy: -2 ms, +10 ms or ±1% (which ever is greater), ON-time synchronized to AC line

Caution:

1. Do not mount controls in high vibration areas without shock mounts.
2. Do not mount controls in areas of high dust or corrosive atmospheres without a protective enclosure.
3. Do not use a converter or inverter for the power source.
4. Do not mount control in high transient voltage areas without an isolation transformer.
5. Do not leave control box open.
6. Do not allow a local repair shop to repair the controls, as we employ some very sophisticated components that could be further damaged. For service, call us directly: 800-323-2593.

DUSTRONIX™ Pressure Differential Meter

Model DNC-PS700-A10

FEATURES

- 51 element tri-color LED meter movement
- ΔP control relay output: programmable, normally open or normally closed
- ΔP alarm relay output: programmable, normally open or normally closed
- Cleaning status LED
- Alarm status LED
- 0-10" w.c. ΔP range
- Source or sink 4 to 20 mA ΔP output
- 1/4 DIN panel mountable
- NEMA 4 compatible
- 3-digit, 7-segment alpha-numeric display
- Removable finger-safe terminations
- Replaces most popular ΔP switches/gauges
- Non-volatile memory
- User selectable program access code
- Universal input voltage

Programmable Parameters:

- Alarm Low/High setpoints
- Cleaning Low/High setpoints
- Alarm relay (normally open or normally closed)
- Cleaning relay (normally open or normally closed)
- Units of measure (inches, w.c. or kPa)
- Security code (user settable)
- ΔP offset compensation capability

The DUSTRONIX Pressure Differential Meter is designed to interface with NCC dust collector controls as well as other controllers. This meter is capable of measuring differential pressure and displaying that value in both analog bargraph and digital displays. Both Low/High Cleaning and Low/High Alarm setpoints can be programmed with relay outputs. The Cleaning relay will energize when the measured pressure exceeds the High Cleaning Setpoint, and will de-energize when the pressure goes below the Low Cleaning Setpoint. The Alarm relay will energize whenever the measured pressure exceeds the High or Low Alarm Setpoint.

The DUSTRONIX Pressure Differential Meter will accept either a 0 to 10" w.c. pressure input or a 4 to 20 mA input. A 4 to 20 mA output loop is provided when the internal pressure sensor is used. A 3-digit security code is also provided to prevent unauthorized changes. The meter is equipped with non-volatile memory which will store all operating parameters when power is removed.

Operating Logic: The DUSTRONIX Pressure Differential Meter is shipped with factory default settings (see details below). A pressure or 4 to 20 mA input needs to be connected, outputs wired as required, and power applied to have a functioning system. Program parameters can now be set for the specific application.

SPECIFICATIONS

FACTORY DEFAULT SETTINGS

Low Alarm Setpoint = 1.0
High Alarm Setpoint = 8.0
Low Cleaning Setpoint = 2.0
High Cleaning Setpoint = 4.0
Alarm Relay = Ano
Cleaning Relay = Cno
Units = IN
Security Code = 0.0.0.

INPUTS

Voltage: 100-240 VAC, 50/60 Hz
Power Consumption: 5 VA max. at 240 VAC

OUTPUTS

Alarm Output Type: Form A relay contact, programmable normally open or normally closed
Alarm Output Rating: 5 A at 240 VAC/30 VDC
Control Output Type: Form-A relay contact, programmable normally open or normally closed
Control Output Rating: 5 A at 240 VAC/30 VDC

CURRENT LOOP

Type: 4 to 20 mA current loop, switch selectable sink/source, represents 0 to 10" w.c. Δ pressure
Accuracy: ± 0.3 mA of displayed pressure
Measurement: Current of 4 to 20 mA or pressure of 0 to 10 in. water

MECHANICAL

Enclosure: 1/4 DIN meter face
Material: 304 stainless steel
Electrical Terminations: Removable screw terminals, 14-22 AWG
Pressure Terminations: Removable 0.125" hose-barb type fittings

PRESSURE SENSOR

Type: Silicon piezoresistive transducer
Measurement Range: 0.0 to 10.0 in. water (0-2.5 KPa)



The PS700 may be purchased separately as an accessory to NCC Dust Collector Controls, as well as other controllers

ORDERING INFORMATION

INPUT VOLTAGE	PART NUMBER
100 to 240 VAC	DNC-PS700-010

ACCESSORY	DIMENSIONS	PART NUMBER
NEMA 4 enclosure for DNC-PS700-010	8" x 6" x 3.5"	BOX-A0806-CHNF

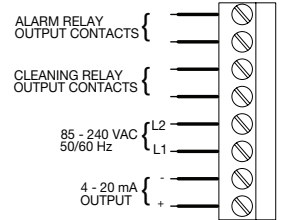
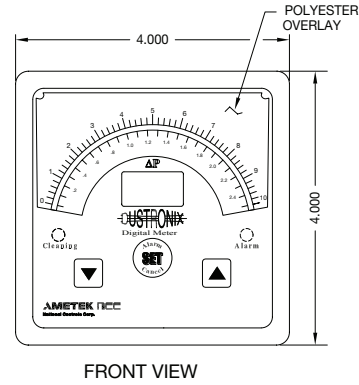
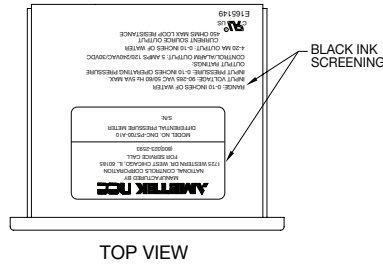
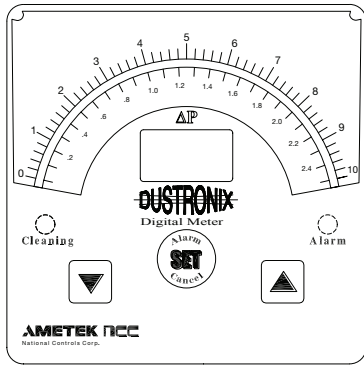

ELECTRICAL CONNECTIONS
FOR REMOVEABLE 8 POSITION CONNECTOR

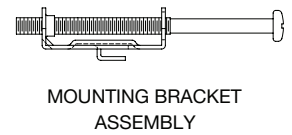
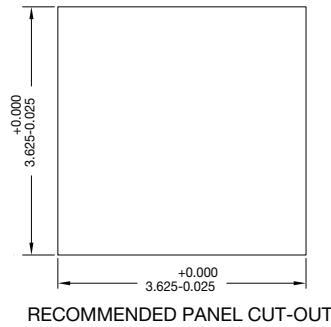
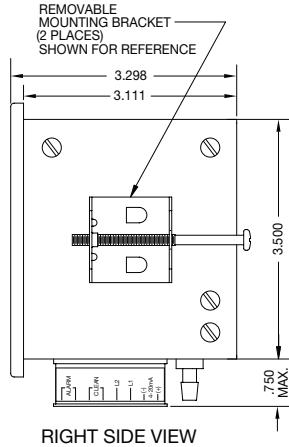
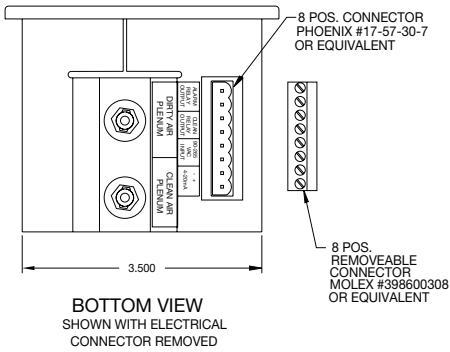

MOUNTING BRACKET ASSEMBLY

Accuracy: ±2% of full scale at 77°F (25°C); ±5% of full scale over temperature and voltage range

Maximum Continuous Pressure: 10 psi

DISPLAYS

Units: Programmable for in. water or kPa

Bargraph Display: 51 element tri-color LED analog differential pressure bargraph

Green = Differential pressure

Yellow = Cleaning setpoints

Red = Alarm setpoints

Digital Display: 3-digit, 7-segment differential pressure display, 0.3 in. tall

Range: 00.0 to 10.0 in. (00.0 to 02.5 KPa), shows "OPn" with no sensor connected or with vacuum applied

Discrete LED Indicators:

Cleaning = Green

Alarm = Red / Yellow

ENVIRONMENTAL

Operating Temperature Range: 32° to 150°F (0° to 65°C)

Protection: Conformal coating on PCB for humidity and vibration

Caution:

1. Do not mount controls in high vibration areas without shock mounts.
2. Do not mount controls in areas of high dust or corrosive atmospheres without a protective enclosure.
3. Do not use a converter or inverter for the power source.
4. Do not mount control in high transient voltage areas without an isolation transformer.
5. Do not leave control box open.
6. Do not allow a local repair shop to repair the controls, as we employ some very sophisticated components that could be further damaged. For service, call us directly: 800-323-2593.

Intelligent, AC-Input, Pulse Cleaning of Bag House Dust Collectors

Models DNC-T2310 and DNC-T2320

FEATURES

- On-board differential pressure sensor
- 4 - 20 mA output for DP
- 8 character alpha-numeric display
- Microprocessor based control for stable timing from -40°C to 65°C
- **Enhanced timer option:** monitor additional devices; record dust collector data; network timers together remote network monitor; remote network control
- RS232 port for remote monitor and control
- Automatic output setup capability
- Expanded cycle mode allows additional dust collector controllers to expand output capabilities
- High pressure alarm indication
- Output fault detection
- Alarm output contacts
- Alarm input sensors
- **Pulse time:** line synchronized to eliminate 8 ms triac turn off variation per output
- 10 A 400 V output triacs for maximum protection against output shorts; 200 VA load rating
- Conformally coated for protection against vibration, humidity, and contamination
- **Metal chassis provided:** for mounting directly into nema 4 box
- Timer functionally tested to eliminate field failures
- **Input protection:** 30 joule metal oxide varistor
- **One year warranty:** warranted to be free from defects in materials or workmanship for one year from date of manufacture
-  File #E65038

Models T2310 and T2320 are micro-processor-based bag house filter controllers which combine a ten or twenty output sequencer with a solid state differential pressure sensor. This offers a small, low-cost replacement to the separate solid state sequencer and pressure gauge combination most often used in on-demand pulse jet cleaning systems. These controllers will sense the pressure difference across the filters of a bag house and initiate a cleaning

cycle when the filters start to impede the air flow. When the pressure drops to normal the controller will stop cycling.

Standard Operating Logic: The timers can operate in the following modes:

- **Auto output:** only configured outputs will be pulsed. Output faults will be detected and indicated.
- **Manual output:** outputs will recycle after last output used.
- **Output step:** a single cleaning pulse can be initiated by pressing the output step key regardless of pressure input.
- **Continuous cycle:** controller will cycle indefinitely when the bypass/cycle down input is shorted.
- **Cycle down:** the outputs will be pulsed through a user selected number of complete cycles when the bypass/cycle down input is shorted. This cycle will occur regardless of pressure input.
- **Expanded output mode:** controller will cycle to output #10 or #20, then will initiate an extended output mode via the alarm input and output terminals to NCC's DNC-T2000 series dust collector controllers. This will facilitate systems which require greater than 10 or 20 outputs.

Standard Timer Operation Status

Indication: The Timer can show the following information on its 8-character alpha-numeric display during normal operation:

- DP from 0" to 15" water column
- High or Low DP Alarms
- Solenoid Fault Conditions
- Current Output being Pulsed
- Auxiliary Alarm Input Closures

Upon occurrence of any alarm event, the alarm status is reported on the display along with the output number that was pulsed during the time of the event.

- **Alarm Outputs:** The isolated Alarm Output contacts will close for alarm conditions such as output faults, high pressure alarm, warm-up failure, etc. During an alarm condition, a corresponding message is displayed.
- **Alarm Input:** A closure across the Alarm Input terminals will be indicated on the display as well as initiate the Alarm Output.



In addition to the standard operation of the T2310 and T2320, an enhanced operation option is available with the use of the DNC-T2300-I/O Remote Input/Output module in conjunction with the DNC-T2300-DSP Remote Annunciator Panel. The T2310 and T2320 Timers along with the DNC-T2300-I/O constitutes the Enhanced Timer system which allows the user to monitor and record the data parameters associated with a dust collector system. This system can range in size from 1 to 255 dust collectors, all reporting to a central location, the DNC-T2300-DSP.

Enhanced Timer Operation

Status Indication: The Timer can show the following information on its 8 character alpha-numeric display during normal operation:

- DP from 0" to 15" water column
- High or Low DP Alarms
- Solenoid Fault Conditions
- Current Output being Pulsed
- Auxiliary Alarm Input Closures
- DNC-T2300-I/O Analog Input Status
- DNC-T2300-I/O Alarm Input Closures

Upon occurrence of any alarm event, the alarm status is reported on the display along with the output number that was pulsed during the time of the event.

RS232 Port:

- **Remote Terminal:** An ANSI type terminal is required for remote monitoring and programming of the controller. Connection to the controller is made via the RS232 port (9 pin D-Sub connector). All the functions and display status accessible from the controller are available through the ANSI terminal.
- **Remote I/O Interface:** The 2310/2320 controllers are capable of communication with the DNC-T2300-I/O board via the RS232 port. This allows the user to monitor up to three 4-20 mA analog inputs, three contact closure type inputs, and one Type J thermocouple. The I/O module is programmed via the 2310/2320 keypad and can be user defined to set alarm points from remote sensors of parameters such as emission, air flow, pressure, broken bags, fan motor current, etc. Refer to the data sheet for the DNC-T2300-I/O for additional information.

Programming Logic: The controller as supplied from the factory will require user configuration. Upon application of power the display will indicate SETUP. The operator must then configure the various operating parameters using the six key keyboard of the controller before normal cleaning operation can begin. The programmable parameters for Standard Operation as displayed are:

• **OUTPUT**

Auto Configuration: will automatically sense the solenoids connected to the outputs and will only pulse those outputs during cleaning cycles.

Manual Configuration: the controller will pulse each output until the last output programmed and then recycle to output #1.

- **LAST:** the number of the last output used.
- **LO DP:** Low Pressure Setpoint, the pressure at which the controller will stop its cleaning cycle.
- **HI DP:** High Pressure Setpoint, the pressure at which the controller will start its cleaning cycle.
- **ON:** Output Solenoid On Time.
- **OFF:** Off Delay Time Between Output Solenoid Activation.
- **ALARM:** High Differential Pressure Alarm Set-point, the pressure at which the controller will close its alarm contacts.

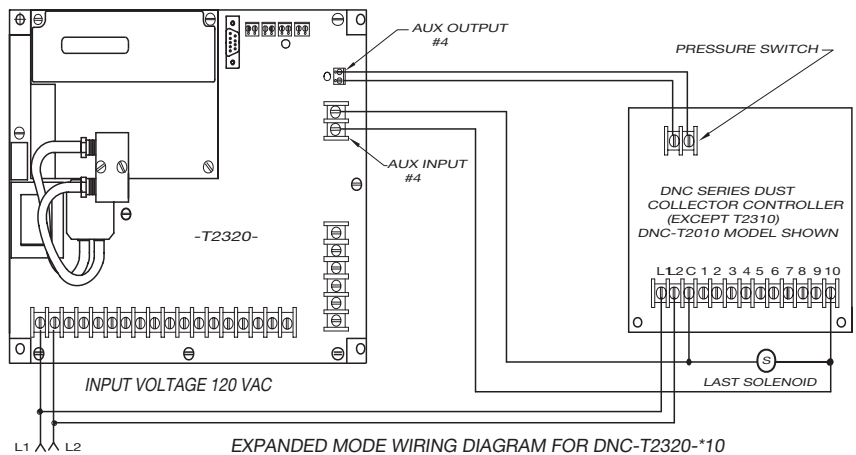
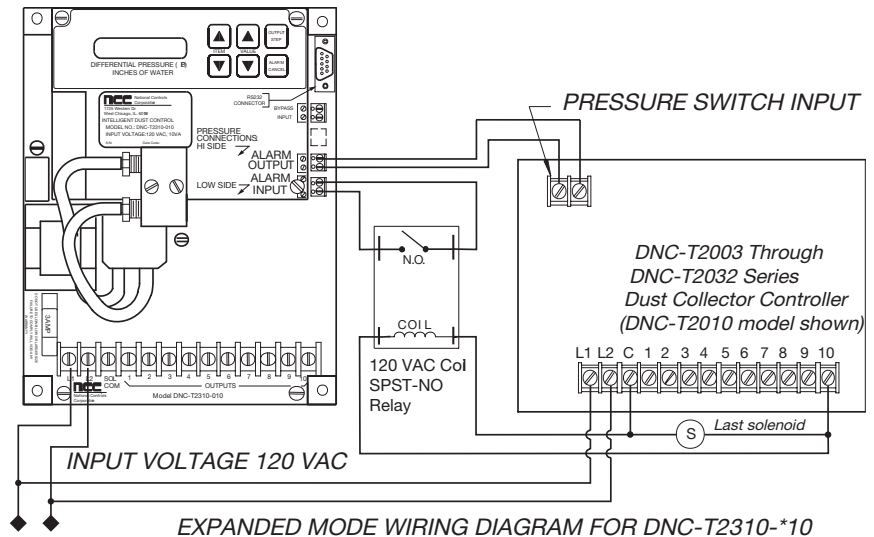

For enhanced timer programming information, see IDC Programming Tree on page 4-6.

Additional Features: The 2310/2320 controllers also provide:

- **4 - 20 mA Output Loop:** This output will provide a continuous reading from 4 -20 mA corresponding to the sensed differential pressure range of 0" to 15" water column. This is a standard feature.
- **24 Hour Time/Day/Month Clock:** The clock feature will allow a daily automatic turn on and turn off command to be implemented by the controller. It can be programmed to start and stop the cleaning cycles for up to seven events per week. This is an optional feature found on the B-series models.

Caution:

1. Do not mount controls in high vibration areas without shock mounts.
2. Do not mount controls in areas of high dust or corrosive atmospheres without a protective enclosure.
- 3 Do not use a converter or inverter for the power source.
4. Do not mount control in high transient voltage areas without an isolation transformer.
5. Do not leave control box open.
6. Do not allow a local repair shop to repair the controls, as we employ some very sophisticated components that could be further damaged. For service, call us directly: 800-323-2593.

SPECIFICATIONS

FACTORY DEFAULT SETTINGS

Lo Pressure = 2" water column
HI Pressure = 4" water column
Alarm Pressure = 14" water column
Output Quantity = 10
Off Time = 15 seconds
On Time = 0.10 seconds
Output Configuration = Manual
I/O Expansion = No

INPUTS

Voltage: 105 -135 VAC, 50/60 Hz.
Maximum Ratings at 135 VAC Input Voltage:
 Power Consumption: 10 VA, without loads

DNC-T2310:

Bypass Switch Open Circuit Voltage: 24 VDC
 Bypass Switch Short Circuit Current: 4.3 mA
 Alarm Inputs 1-3:
 Open Circuit Voltage: 24 VDC
 Short Circuit Current: 4.3 mA

DNC-T2320:

Bypass Switch Open Circuit Voltage: 24 VDC
 Bypass Switch Short Circuit Current: 4.3 mA
 Alarm Inputs 1-3:
 Open Circuit Voltage: 24VDC.
 Short Circuit Current: 4.3 mA
 Auxiliary Input #4: 90-135 VAC, 50/60 Hz;
 6.6 mA at 135 VAC

AIR PRESSURE MEASUREMENT

Sensor Type: Silicon piezoresistive transducer with dual inlets

Measurement Range: 0.0 to 15.0" of water

Accuracy: ±2% of full scale at 25°C ±6% of full scale over temperature and voltage range

Maximum Continuous Pressure: 10 psi

DISPLAY

Type: 8-character, 16-segment vacuum fluorescent display; characters .2" high, alpha-numeric

TIMING:

Solenoid ON Time Range: .01-.50 sec.

Solenoid OFF Time Range: 7 -999 sec.

Timing Accuracy: -2 ms, +10 ms or ±1%, whichever is greater; Solenoid ON Time is synchronized to the AC line

OUTPUTS

Maximum Solenoid Output: 200 VA or W at max. duty cycle

Solenoid Output Voltage: Input voltage 2.5 VAC at 200 VA load

Solenoid Output Type: Solid state triac

Solenoid Output Short Circuit Protection:

3 AG fast acting
 120 V units: 3 A/250 VAC fuse
 240 V units: 1.5 A/250 VAC fuse

DNC-T2310:

Alarm Output Type: 1-FORM A relay contact
 Alarm Output Rating: 3 A at 120/240 VAC

DNC-T2320:

Alarm Output Type: 1-FORM A relay contact
 Alarm Output Rating: 3 A at 120/240 VAC
 Aux. Output #4 Type: 1-FORM A relay contact
 Aux. Output #4 Rating: 3 A at 120/240 VAC

Current Loop:

Type: 4 - 20 mA current loop, current is sourced by the controller. Signal represents 0 to 15 inches of differential pressure (DP)
 Accuracy: ±.3 mA of displayed pressure

SERIAL COMMUNICATIONS

Type: RS232

Terminal Emulation: ANSI VT100

Mode: 9600 Baud, 8-Data Bits 1-Start Bit 1-Stop Bit, X ON - X OFF, No Parity

Connector: 9-Pin male IBM compatible D-SUB connector

ENVIRONMENTAL

Operating Temperature Range: -40° to 65°C

Environmental Protection: Conformal coating for humidity and vibration

Contact factory for additional information

ORDERING INFORMATION

OUTPUTS	DESCRIPTION	AUX. INPUTS	INPUT VOLTAGE	OFF TIME	PART NUMBER
10	4-20 mA Loop	3	105 to 135 VAC	7 to 999 sec.	DNC-T2310-A10
10	4-20 mA Loop and 24 hr. clock	1	105 to 135 VAC	7 to 999 sec.	DNC-T2310-B10
10	4-20 mA Loop	3	210 to 270 VAC	7 to 999 sec.	DNC-T2310-A220
10	4-20 mA Loop and 24 hr. clock	1	210 to 270 VAC	7 to 999 sec.	DNC-T2310-B220
20	4-20 mA Loop	4*	105 to 135 VAC	7 to 999 sec.	DNC-T2320-A10
20	4-20 mA Loop and 24 hr. clock	2*	105 to 135 VAC	7 to 999 sec.	DNC-T2320-B10
20	4-20 mA Loop	4*	210 to 270 VAC	7 to 999 sec.	DNC-T2320-A220
20	4-20 mA Loop and 24 hr. clock	2*	210 to 270 VAC	7 to 999 sec.	DNC-T2320-B220
10	4-20 mA Loop in NEMA 4X box	3	105 to 135 VAC	7 to 999 sec.	DNC-T2310-KIT
20	4-20 mA Loop in NEMA 4X box	4*	105 to 135 VAC	7 to 999 sec.	DNC-T2320-KIT

ACCESSORY	DIMENSIONS	PART NUMBER
NEMA 4 Enclosure - Steel	10" x 8" x 4"	BOX-A1008-CHNF
NEMA 4 Enclosure - Steel	12" x 10" x 5"	BOX-A1210-CHNF
NEMA 4 Window Enclosure - Fiberglass	12" x 10" x 6"	BOX-A1210-CHSC
Pilot Lamp	NEMA 4 Rated Red Light	ASL-00RED-NEMA-4
ON/OFF Switch	NEMA 4 Rated w Legend Plate	MSW-0DPST-001

* When unit is configured for expanded mode operation, input #4 is not available

AMETEK NCC offers NEMA 4 type enclosures for mounting our controls. These enclosures are made of heavy gauge steel or fiberglass and have a continuous hinge cover. All seams are continuously welded. The finish is gray hammer-tone enamel inside and out, over phosphatized surfaces for steel units, smooth gray finish for fiberglass units.

Model DNC-T2310-A10

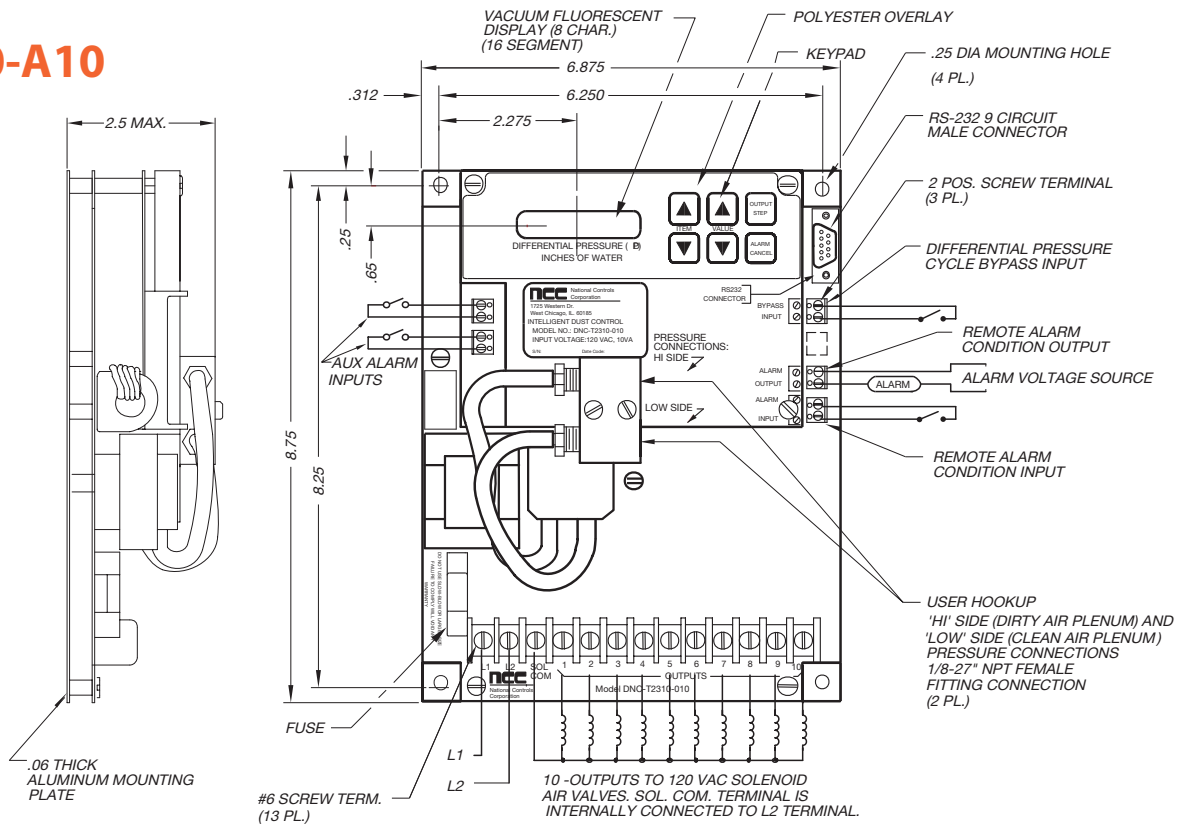

Model DNC-T2320-A10

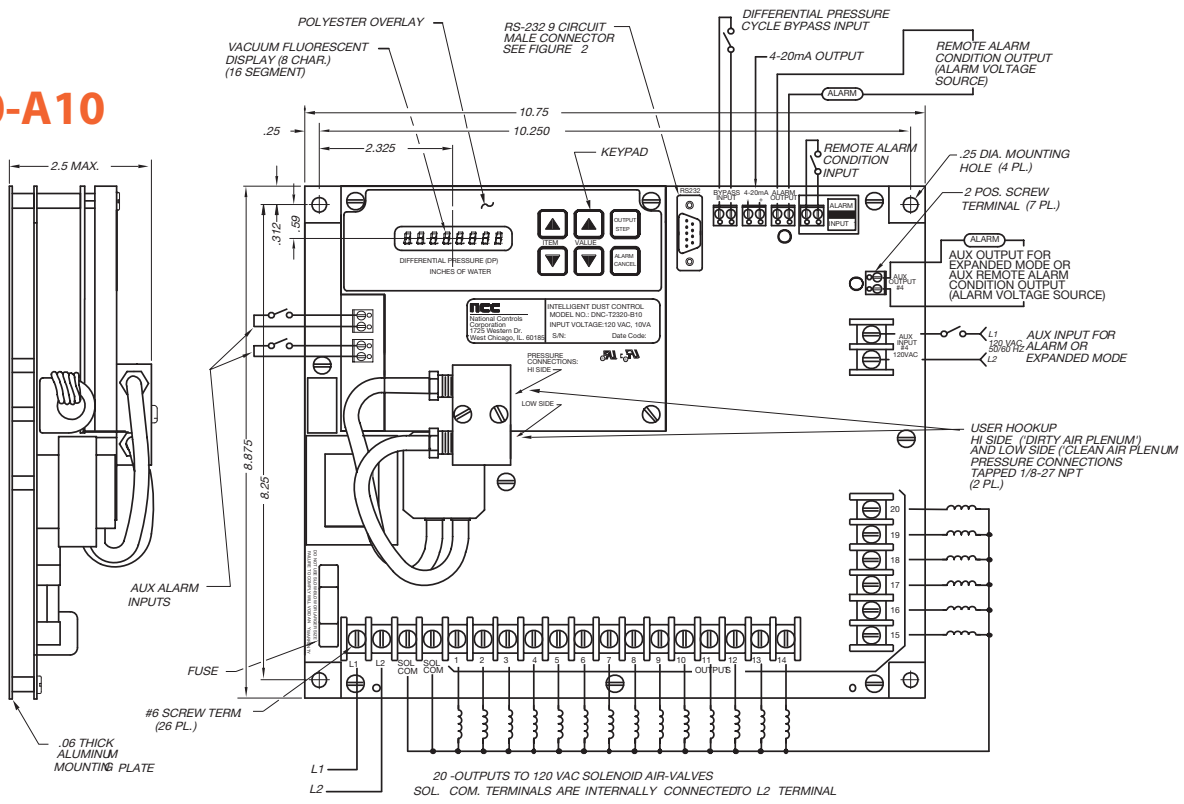

4-18 DUST COLLECTOR CONTROLS

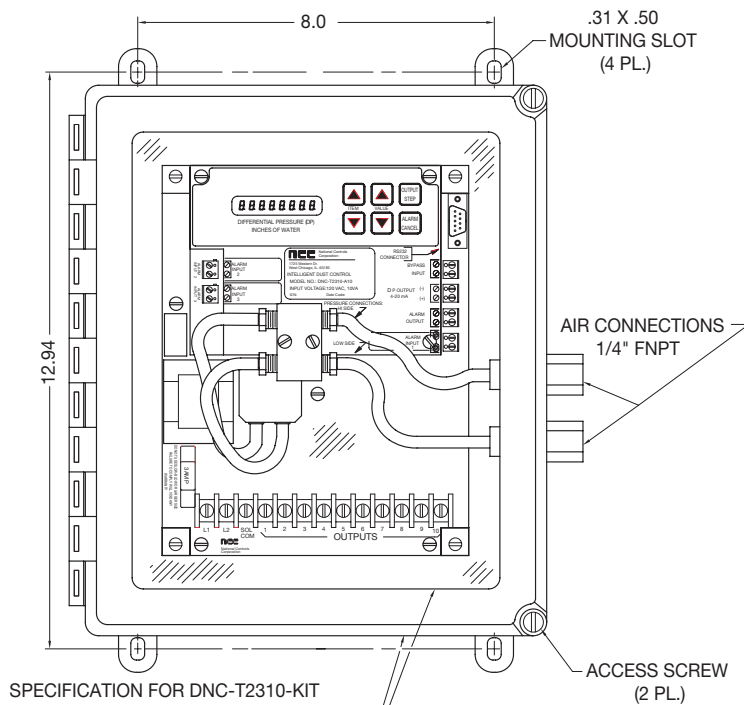

12 X 10 X 6
FIBERGLASS POLYESTER HINGED
NEMA TYPE 4X ENCLOSURE
WITH CLEAR WINDOW 10.25 X 8.25

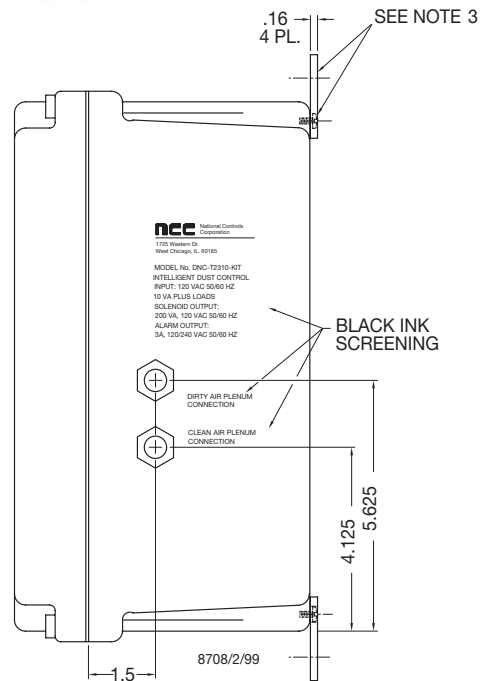

- NOTES:
1. DIMENSIONS: INCHES
2. NOT ALL COMPONENTS ARE SHOWN.
3. 4 MOUNTING FEET AND 4 SCREWS ARE SHIPPED WITH THE UNIT (NOT INSTALLED).

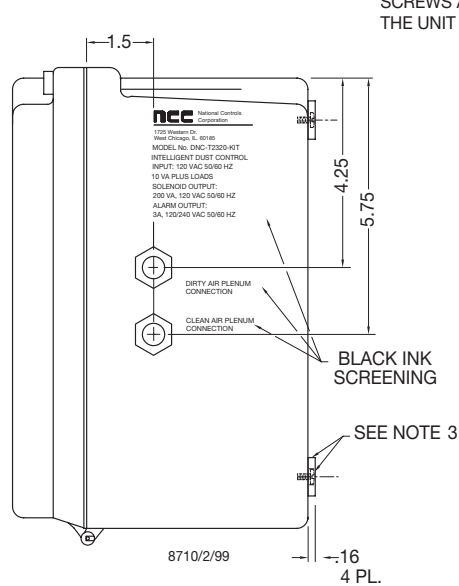
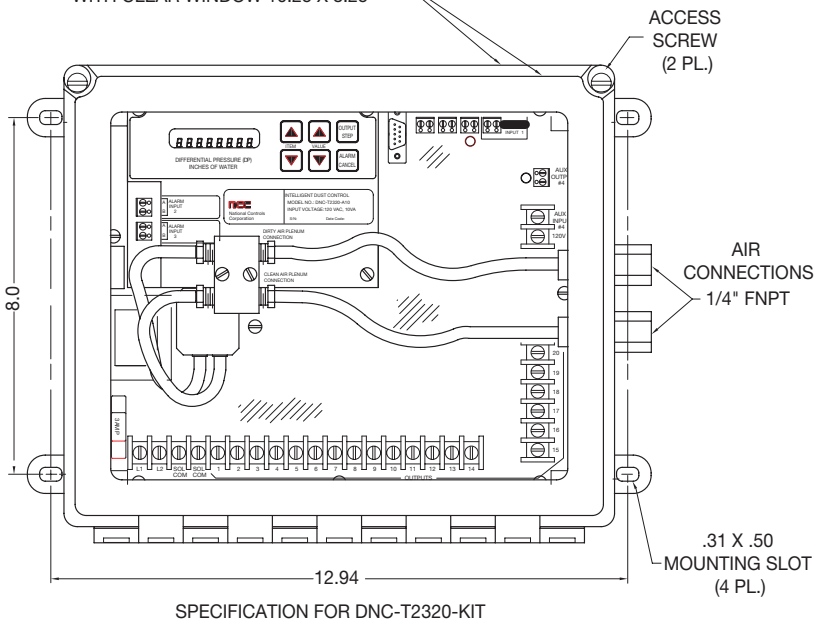

Product Overview: The models DNC-T2310-KIT and DNC-T2320-KIT are micro-processor-based, 10/20 output sequencer, reverse air bag house filter controllers. Each is housed in a NEMA 4X fiberglass enclosure which has a clear window for monitoring the controller's display. The enclosure dimensions are 12 inches high by 10 inches wide and 6 inches deep. The door is hinged

in the left for the 2310-KIT and the bottom for the 2320-KIT, and can be opened by loosening two screws located on the side opposite the hinge.

Air connections are made by mounting to the 1/4-inch NPT female connectors on the right side of the unit. Connectors are labeled as DIRTY AIR PLENUM CONNECTION or the high pressure side of

the filter, and CLEAN AIR PLENUM CONNECTION which is the low pressure side of the filter. Holes must be made in the enclosure to connect conduit fittings for electrical power to the controller.

For operation of the controls, refer to specifications on page 4-3.

IDC Programming Tree

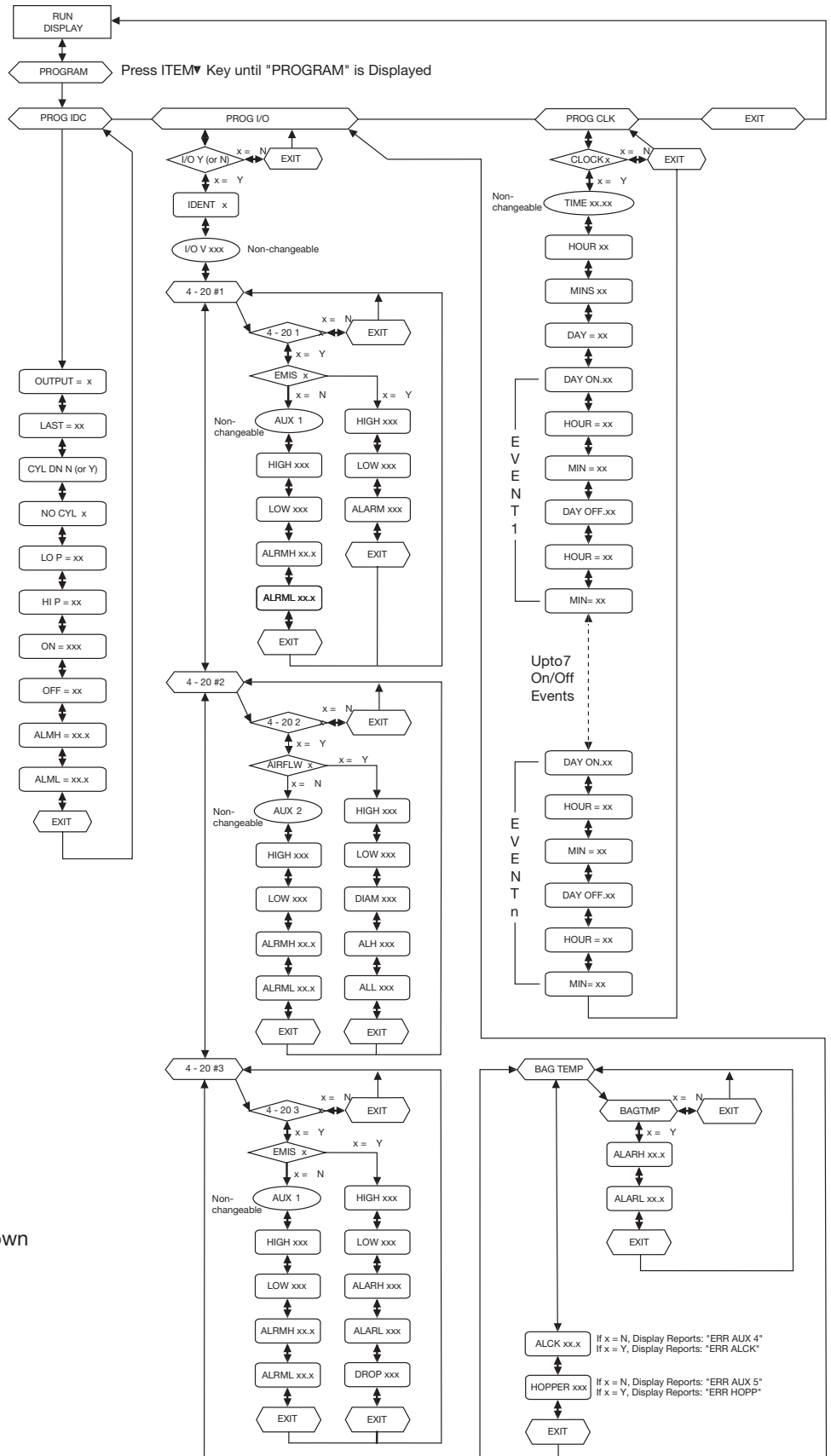

Display Keypad

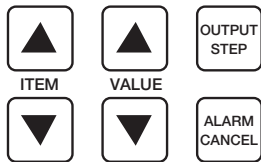

Use the ▲ and ▼ **Item Keys** to navigate within the Programming Tree. The ▲ Key moves up the Tree. The ▼ Key moves down the Tree.

Use the ▲ and ▼ **Value Keys** to select Program Options, or change parameters. The ▲ Key increments value. The ▼ Key decrements value

Intelligent Dust Collector Controller Remote Input/Output Module

Model DNC-T2300-I/O

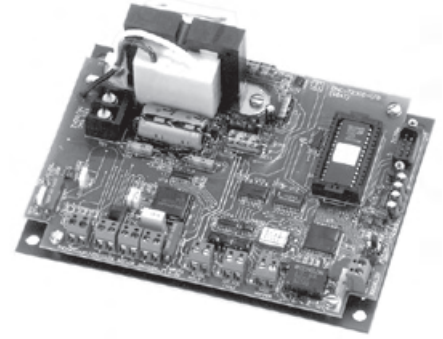

FEATURES

- Enhances T2310 and T2320 timer operation
- Monitors three 4-20 mA analog inputs
- Monitors three switched inputs
- Monitors one type J thermocouple
- Operating temperature range from -40°C to 65°C
- Communicates via RS232 port to intelligent controller
- Communicates via 2 wire network to remote sites
- Interconnectable for overall system management
- Large storage capacity for historical trending of system data
- Aids in system diagnostics
- Increases overall system efficiency
- Conformally coated for protection against vibration, humidity, and contamination
- **Metal chassis provided:** for mounting directly into NEMA 4 box
- Timer functionally tested to eliminate field failures
- **One Year Warranty:** warranted to be free from defects in materials or workmanship for one year from date of manufacture
- File #E65038

The Model DNC-T2300-I/O module provides several functions. It communicates with a T2310 or T2320 Dust Collector Timer via the RS232 port to form an Enhanced Timer system, and it communicates pertinent system data to remote control/display devices via the 2 wire Enhanced Timer Network. It also incorporates three 4-20 mA current loop inputs, three contact closure type inputs, and one type J thermocouple input. In addition, the I/O board provides 16K bytes of

non-volatile memory for the storage of up to one year of input trending data. The I/O board requires either a T2310 or T2320 Timer to program and operate the board and a T2300 Display Panel to access data trending reports.

The I/O board offers significant versatility to the Intelligent Dust Collector Controller system. It can monitor, display, alert, and store dust collector system parameters from pressure sensors, emission monitors, plenum air flow sensors, broken bag detectors, fan motor current sensors and any other device which has a 4-20 mA current output or contact closure output. The unit works in conjunction with the T2310 and T2320 Timers and also with the DNC-T2300-DSP Display Panel.

Operating Logic: Upon application of power to the unit, communication will be established with the T2310 or T2320 Timer via the RS232 port. The I/O board can then be configured for the inputs provided to it by using the keypad on the controller. Alarm setpoints and 4-20 mA scaling can be programmed for different types of inputs to be displayed in a meaningful fashion on the

controller's 8 character display and output via the two wire Enhanced Timer Network to the DNC-T2300-DSP remote display panel.

Inputs: There are three general purpose 4-20mA current loop inputs which are configured by the Timer. Depending on how the particular 4-20 mA inputs are configured, the messages that appear on the Timer's display would either show a generic range of 0-100% based on the 4-20 mA input or data units specific to three pre-programmed sensing devices would be displayed.

There are two general purpose switched inputs which will monitor and report up to two contact closures as alarm conditions to the Timer, and one contact closure input which allows the user to place the Enhanced Timer system in standby mode.

ORDERING INFORMATION

INPUT VOLTAGE	PART NUMBER
105 to 135 VAC	DNC-T2310-A10
210 to 270 VAC	DNC-T2310-A220

ACCESSORY	DIMENSIONS	PART NUMBER
Enclosure	10" x 8" x 4"	BOX-A1008-CHNF

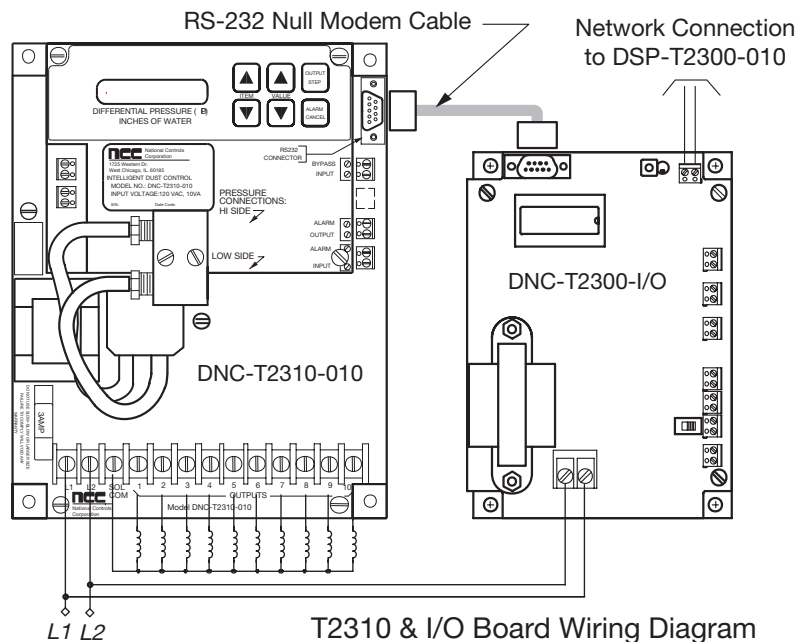

The I/O board also has the capacity to monitor the temperature of a type J thermocouple in °F, with a range of 40°F to 700°F.

History Trending: The I/O board has the capability to store data generated by the Timer connected to its RS232 port as well as data generated by the various sensing devices connected to its inputs. Data history is subdivided into three categories: Short Term History, Long Term History, and Alarm History.

Short Term History is a time and date stamped recording of the hourly averages of the 4-20mA inputs, the Differential Pressure from the Timer, the highest temperature recorded, and the number of outputs that were pulsed in that hour. This Short Term History period is two weeks, after which time the oldest 24 hours of recorded data is averaged along with the highest recorded temperature and the number of outputs that were pulsed for that period and is stored in Long term history.

The **Long Term History** period is one year, after which time the oldest recorded data is discarded to make room for new data.

Alarm History is event driven, if any alarm conditions occur, a time and date stamped "snapshot" of all the system parameters is recorded in a First-In-First-Out circular data buffer. This FIFO buffer can store up to 212 alarm events and is not time dependent.

In order to generate the Data History Reports, a DNC-T2300-DSP Remote Display Panel and a terminal device capable of communicating standard ASCII via an RS232 connection are required.

SPECIFICATIONS

INPUTS

Voltages: 105-135 VAC, 50/60 Hz; 210-270 VAC, 50/60 Hz

4-20 mA Current Loops:

Input Impedance: 401.5 ohms \pm 20 ohms
Accuracy: \pm 1% of applied signal.

#1: Emissions/Aux1 (Sink Capability Only)

User Selectable Functions:

Emissions: Output is percent of full scale input
Generic: Output is percent of full scale input

#2: Air Flow/Aux2 (Sink Capability Only)

User Selectable Functions:

Air Flow: Pitot Tube sensing device required, output range 0 to 6.5 mega SCFM
Generic: Output is percent of full scale input

#3: Manifold/Aux3 (Source or Sink Capability)

Source Voltage: +24v \pm 2v

User Selectable Functions:

Manifold pressure: Output range: 0 to 999 psi
Generic: Output is Percent of full scale input.

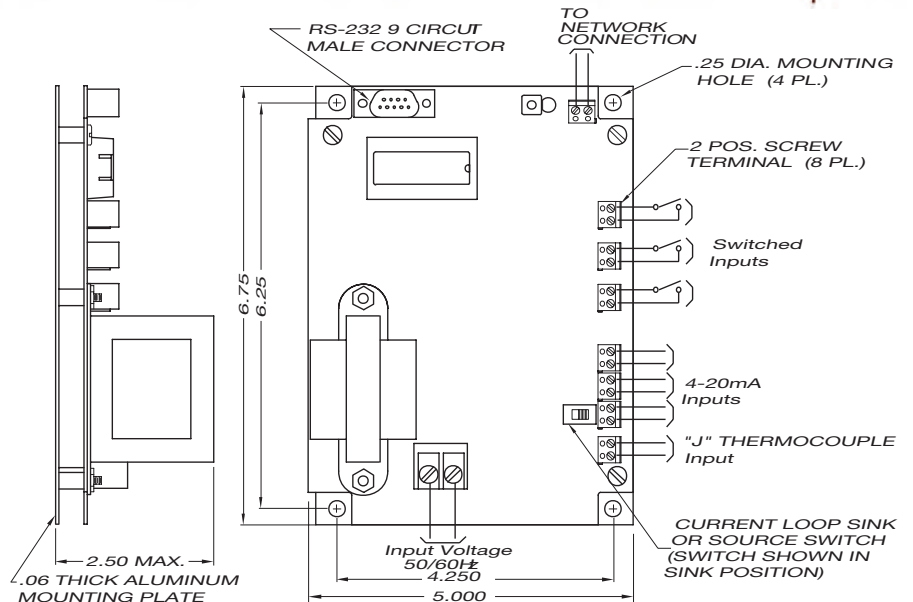

RS-232 Null Modem Cable Wiring Diagram

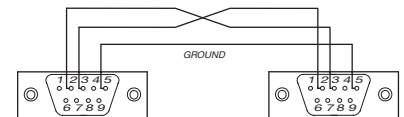

RS232 CONNECTORS (TOP VIEW)

9-PIN RS232 D-SUB (PLUG) CONNECTOR MOUNTED ON CONTROLLER MATES WITH 9 PIN (RECEPTACLE) CONNECTOR AMP #747150-1 OR EQUIV.

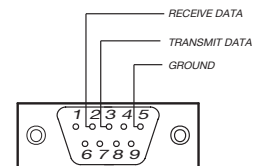

Switched Inputs:

Alarm Input Open Circuit Voltage: 40 VDC
Alarm Input Short Circuit Current: 4.5 mA

#1: Airlock Fault/Aux4 Alarm: Input will be labeled and recorded as either Air Flow or Aux4 depending on user selection.

#2: High Hopper/Aux5 Alarm: Input will be labeled and recorded as either High Hopper or Aux5 depending on user selection.

#3: Standby Function: Dedicated as a Remote Standby Switch Input.

Thermocouple Input:

Thermocouple: Type J
Temp. Measurement Range: -40°F to 700°F
Temp. Measurement Accuracy: \pm 4°F

SERIAL COMMUNICATIONS

Null modem type connection required between controller and I/O board.

Type: RS232

Mode: 4800 baud, 8-data bits 1-start bit 1-stop bit, X ON - X OFF, no parity

Function: Dedicated for communication with a T2300 Series Dust Collector Controller.

Connector: 9-pin male IBM-compatible D-SUB connector. Null modem type connection required between controller and I/O board.

Network Connection:

Type: 2 wire twisted pair
Termination: 52.3 ohm, 1%, 1/8 W resistor
Network Connection Device: FTT-10A Transceiver

ENVIRONMENTAL

Operating Temperature Range: -40° to 65°C

Humidity: 90% non-condensing

Environmental Protection: RTV conformal coating for humidity and vibration

Contact factory for additional information

Caution:

1. Do not mount controls in high vibration areas without shock mounts.
2. Do not mount controls in areas of high dust or corrosive atmospheres without a protective enclosure.
3. Do not use a converter or inverter for the power source.
4. Do not mount control in high transient voltage areas without an isolation transformer.
5. Do not leave control box open.
6. Do not allow a local repair shop to repair the controls, as we employ some very sophisticated components that could be further damaged. For service, call us directly: 800-323-2593.

Intelligent Dust Collector Controller Remote Annunciator Panel

Model DNC-T2300-DSP

FEATURES

- Remotely monitors up to 255 enhanced timers
- Communicates via 2 wire network to enhanced timers
- NEMA 4 front panel access control
- History report generation for 1 year of system data
- Alarm report generation for over 200 alarm events
- Remote PC connection via RS232 port
- 12 tri-color LEDs for at-a-glance system status annunciation
- 2 line x 8 character alpha-numeric display
- Monitors two switched inputs
- Provides one alarm output relay
- Aids in system diagnostics
- Use to increase overall system efficiency
- Operating temperature range from -40°C to 65°C
- **One Year Warranty:** warranted to be free from defects in materials or workmanship for one year from date of manufacture
-  File #E65038

The Model DNC-T2300-DSP is a remote display panel used to monitor and control the parameters of the Enhanced Timer Network, which consists of 1 to 255 Intelligent Dust Collector Controller and I/O Board combinations or Enhanced Timers. The display panel communicates with the Enhanced Timer Network via a simple two wire connection over a distance of up to 1.5 miles. Data generated by the Enhanced Timer Network is presented on a 2 line x 8 character vacuum fluorescent alpha-numeric display. In addition, instantaneous system status is reported by 12 tri-colored LEDs, some of which can be user assigned to monitor specific conditions. The Enhanced Timer Network monitored by the display can be interconnected in a variety of ways: in series, parallel, and/or series-parallel. It is also possible to have more than one DNC-T2300-DSP connected to an Enhanced Timer Network.

Operating logic: Upon application of power to the unit, communication will be established with the Enhanced Timer Network. When everything on the network is normal, all the LEDs will be illuminated green and the data from the first Enhanced Timer on the network will be displayed. If no communication is established, then the message NET FAIL will be displayed and the NETWORK STATUS LED will begin flashing red to indicate a fault.

Each Enhanced Timer on the network is programmed with its unique ID number. When the display is presenting the data from any Enhanced Timer on the network, this ID number will be shown as "TIMER xxx" (with xxx being the ID number) along with the data on the alpha-numeric display. The data from any Enhanced Timer on the network will be presented sequentially in a scrolling fashion on the alpha-numeric display.

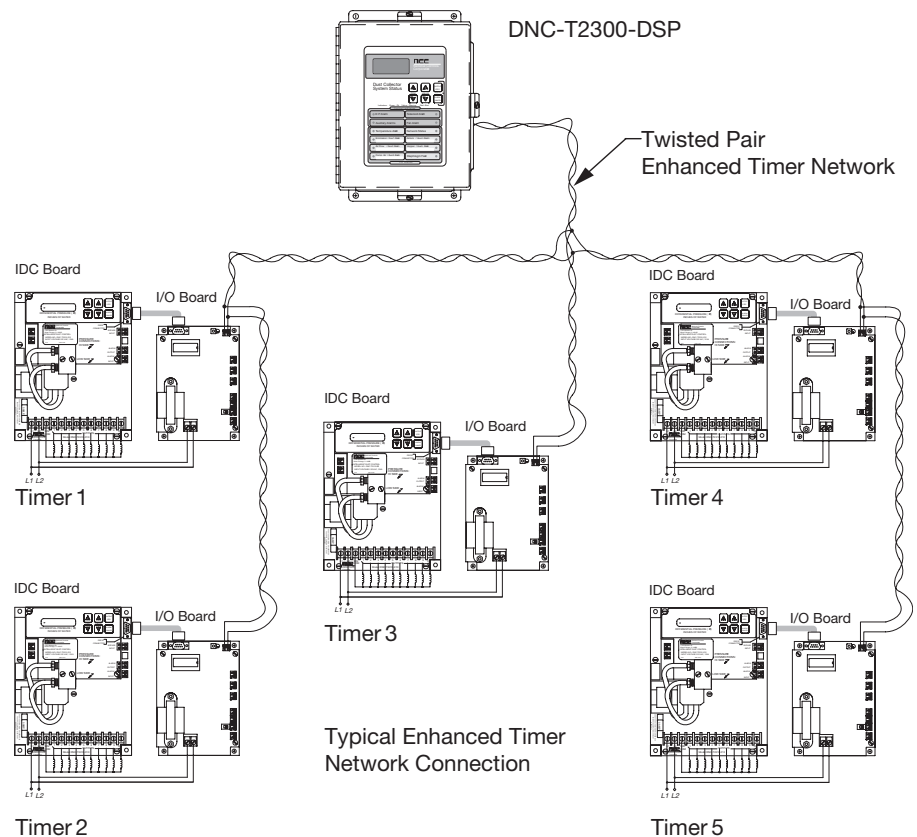

play, for as long as the display is set for that particular timer. Enhanced Timer selection is accomplished by accessing the SELECT TIMER menu item (see programming tree).

If, during the course of normal operation, an alarm occurs on an Enhanced Timer other than that which is being displayed, the display will automatically switch to the Enhanced Timer generating the alarm and show the alarm condition along with all other parameters associated with it. Alarm events are announced by the alpha-numeric display along with a corresponding LED indicator which will begin flashing red until the alarm condition has been cleared or until the ALARM CANCEL key has been pressed.

An additional feature of the display is the normally open Alarm Output Relay, which closes on any alarm condition; this output can be used to switch a signalling device to alert the user. When an alarm condition is present, pressing the ALARM CANCEL key will cause the Alarm Output Relay to open but keep the Alarm status in effect on the display and change the flashing red LED to a steady amber to indicate that the alarm condition has been acknowledged but has not yet been cleared.

The six button keypad similar to that found on the Enhanced Timer can be used to program parameters or generate History Reports of any Enhanced Timer on the network (see programming tree for overview). Programming data is sent over the two wire network to the respective Enhanced Timer. History Report data is sent over the RS232 port on the display to a device which is capable of displaying and/or storing a comma delimited ASCII file format. A typical application would be to connect a laptop PC computer's RS232 port to the display's RS232 port with a null modem cable

ORDERING INFORMATION

INPUT VOLTAGE	PART NUMBER
105 to 135 VAC	DNC-T2300-DSP
210 to 270 VAC	DNC-T2301-DSP

The DNC-T2300-DSP is housed in a NEMA 4 type enclosure ready for mounting. This enclosure is made of heavy gauge steel and has a continuous hinge cover. All seams are continuously welded. The finish is gray hammer-tone enamel inside and out, over phosphatized surfaces.

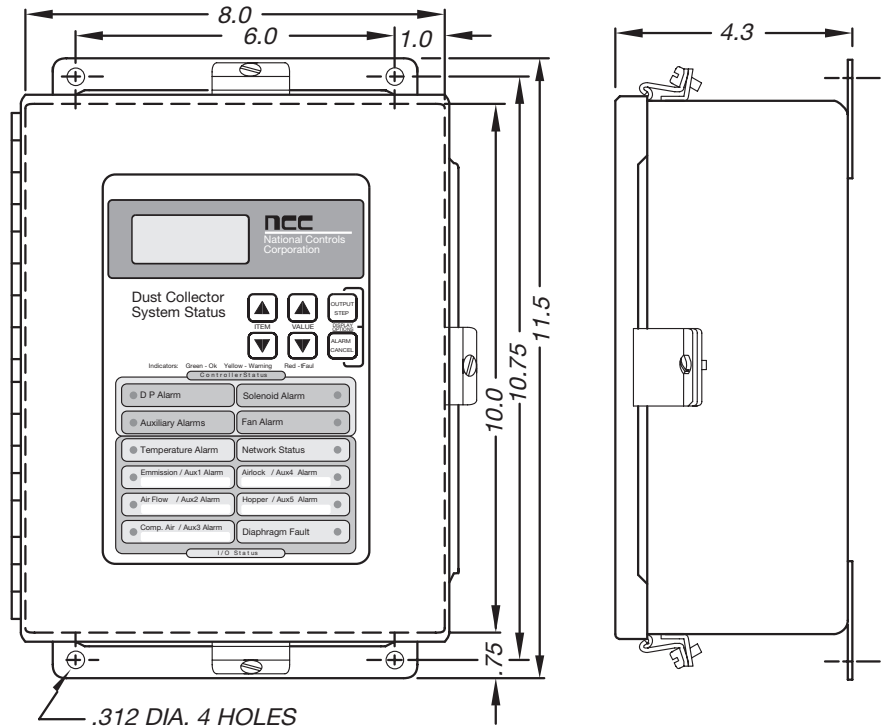

and download a History Report into a file for later analysis in a spreadsheet program. Remote access of the display functions is also available via the RS232 port. Using the same connection as stated above, a PC can be used to display all the data provided by an Enhanced Timer as well as program any facet of the Enhanced Timer Network.

Among the features of the display is a battery backed up, 24 hour Day/Date/Year clock, which maintains the Enhanced Timer Network time for accurate recording of History logging and all alarm events for all of the Enhanced Timers on the network. Furthermore, two Alarm Inputs are provided on the display for monitoring general system alarms or whatever the user desires.

The DNC-T2300-DSP is designed to be used as a central point of control for either a small or large facility which has multiple dust collectors or to monitor a dust collector from a remote location. Since the two wire network utilizes peer-to-peer communication protocol, it is possible to have more than one display connected to the Enhanced Timer Network to report the status of different Timers simultaneously.

RS-232 Null Modem Cable Wiring Diagram

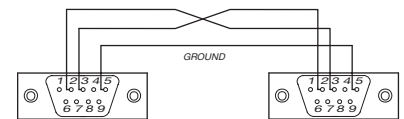

RS232 CONNECTORS (TOP VIEW)
9-PIN RS232 D-SUB (PLUG) CONNECTOR MOUNTED ON CONTROLLER
MATES WITH 9 PIN (RECEPTACLE) CONNECTOR AMP #747150-1 OR EQUIV.

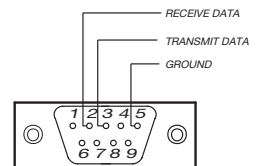

Caution:

1. Do not mount controls in high vibration areas without shock mounts.
2. Do not mount controls in areas of high dust or corrosive atmospheres without a protective enclosure.
3. Do not use a converter or inverter for the power source.
4. Do not mount control in high transient voltage areas without an isolation transformer.
5. Do not leave control box open.
6. Do not allow a local repair shop to repair the controls, as we employ some very sophisticated components that could be further damaged. For service, call us directly: 800-323-2593.

SPECIFICATIONS

INPUTS

Voltages: 105-135 VAC, 50/60 Hz; 210-270 VAC, 50/60 Hz

Switched Inputs:

Alarm Input Open Circuit Voltage: 10 VDC
Alarm Input Short Circuit Current: 13 mA

#1: Display 1 Alarm: Status LED Auxiliary Alarms

#2: Display 2 Alarm: Status LED Auxiliary Alarms

OUTPUTS

Alarm Output

Type: 1-Form A (SPST) relay contact
Rating: 3 A at 120/240 VAC

Display: 2 line x 8 character; alpha-numeric vacuum fluorescent, .3" high

Status LEDs:

Quantity: 12

Type: Tri-Color; Red-Fault, Yellow-Alarm acknowledged, Green-Normal

Status LED Nomenclature:

dP Alarm	Solenoid Alarm
Auxiliary Alarms	Fan/Alarm 1
Temperature Alarm	Network Status
Emission/Aux 1 Alarm	Airlock/Aux4 Alarm
Air Flow/Aux 2 Alarm	Hopper/Aux5 Alarm
Comp. Air/Aux3 Alarm	Diaphragm Fault

Serial Communications: Null modem type connection required between display and terminal or PC

Type: RS232

Mode: 9600 Baud, 8-Data Bits, 1-Stop Bit, No Parity

Function: Dedicated For Communication with an ANSI type VT100 Terminal

Connector: 9-pin male IBM compatible D-SUB connector null modem type connection required between display and terminal or PC.

Network Connection:

Type: 2 wire twisted pair

Transmission Line: 2 wire twisted pair (Belden 85102 or 8471 or equiv. recommended)

Termination: 50 or 100 ohm, jumper selectable resistor

Free Topology: 50 ohm termination on only one end of the network bus. Remove jumper on all other bussed units.; Node-to-Node distance 1640.5 ft. max.; Bus Length 1640.5 ft max.

Double Terminated: 100 ohm termination on each end of the network bus; remove jumper on all other bussed units; bus length 8858.3 ft max.

Network Connection Device: Echelon FTT-10A Transceiver

ENVIRONMENTAL

Operating Temperature: -40°C to 65°C

Storage Temperature: -40°C to 70°C

Humidity: 90% non-condensing

Protection: Conformal coat for humidity and vibration

Contact Factory for Additional Information

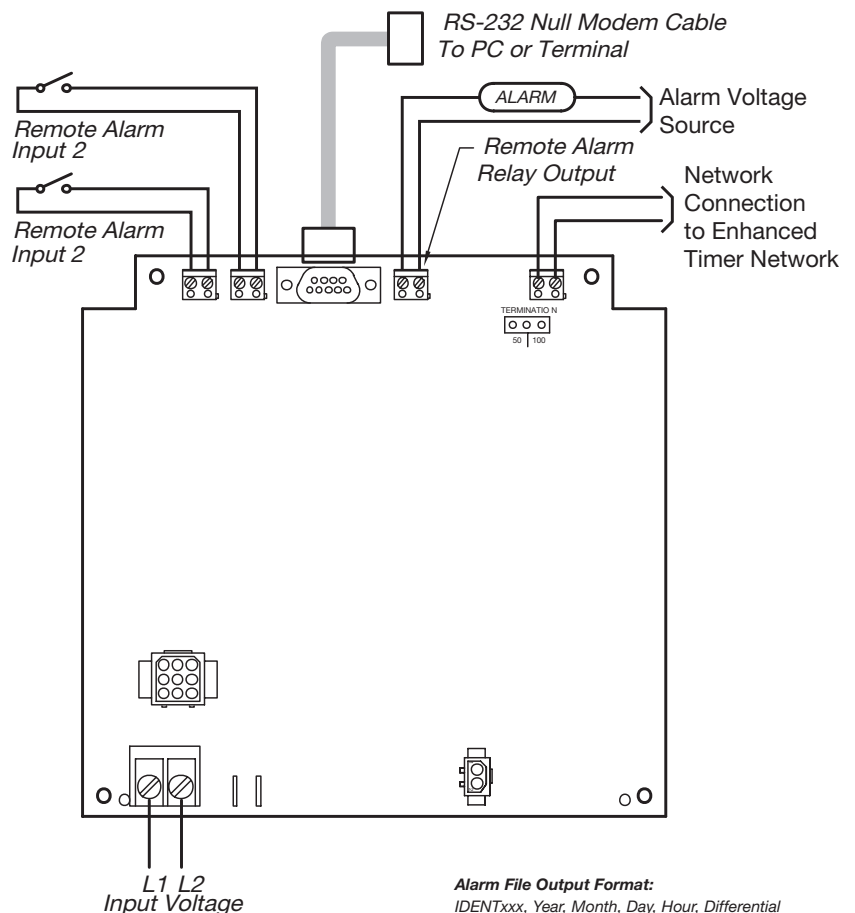

Alarm File Output Format:

IDENTxxx, Year, Month, Day, Hour, Differential Pressure, Emissions, Airflow, Manifold Pressure, Bag Temperature, Temperature Probe Failure, Bad Solenoid, Differential Pressure too Hi/Low, One hour warmup failure, 5 cleaning cycle alarm, External alarm input #1, External alarm input #2, External alarm input #3, External alarm input #4, Triac is shorted on, 0, 0, 0, 0, 0, High emission, High or Low airflow, Manifold pressure current loop out of range, Manifold pressure too low before firing of the solenoid, Manifold pressure did not drop when a solenoid fired, High bag temperature alarm, High hopper alarm, Airlock fault, 0, Bag temperature probe open, Communication fault, Timer fail, 0, 0, 0, 0, Last solenoid that fired before the alarm, Solenoid number that did not fire, Solenoid number which is stuck on, Last solenoid that fired before alarm input #1, Last solenoid that fired before alarm input #2, Last solenoid that fired before alarm input #3, Last solenoid that fired before alarm input #4.

File Output Format:

xxx, xx, xx, xx, xx, xxx, xxx, xxx, xxx, xxx, x, x, x, x, x, x, x, x, x, 0, 0, 0, 0, 0, 0, x, x, x, x, x, x, x, 0, x, 0, x, 0, 0, 0, xxx, xxx, xxx, xxx, xxx, xxx, xxx, CR, LF

Short and Long Term Memory File Output Format:

IDENTxxx(1-255), Year (last 2 digits), Month (1-12), Day(1-31), Hour(0-23), Differential Pressure (in. H₂O), Emissions or AUX1 (percentage), Airflow (SCFM) or AUX2 (percentage), Manifold Pressure (psi) or AUX3 (percentage), Bag Temperature (°F), Number of Solenoids that fired.

File Output Format:

xxx, xx, xx, xx, xx, xxx, xxx, xxx, xxx, xxx, xxx, xxx, CR, LF

DNC Programming Tree

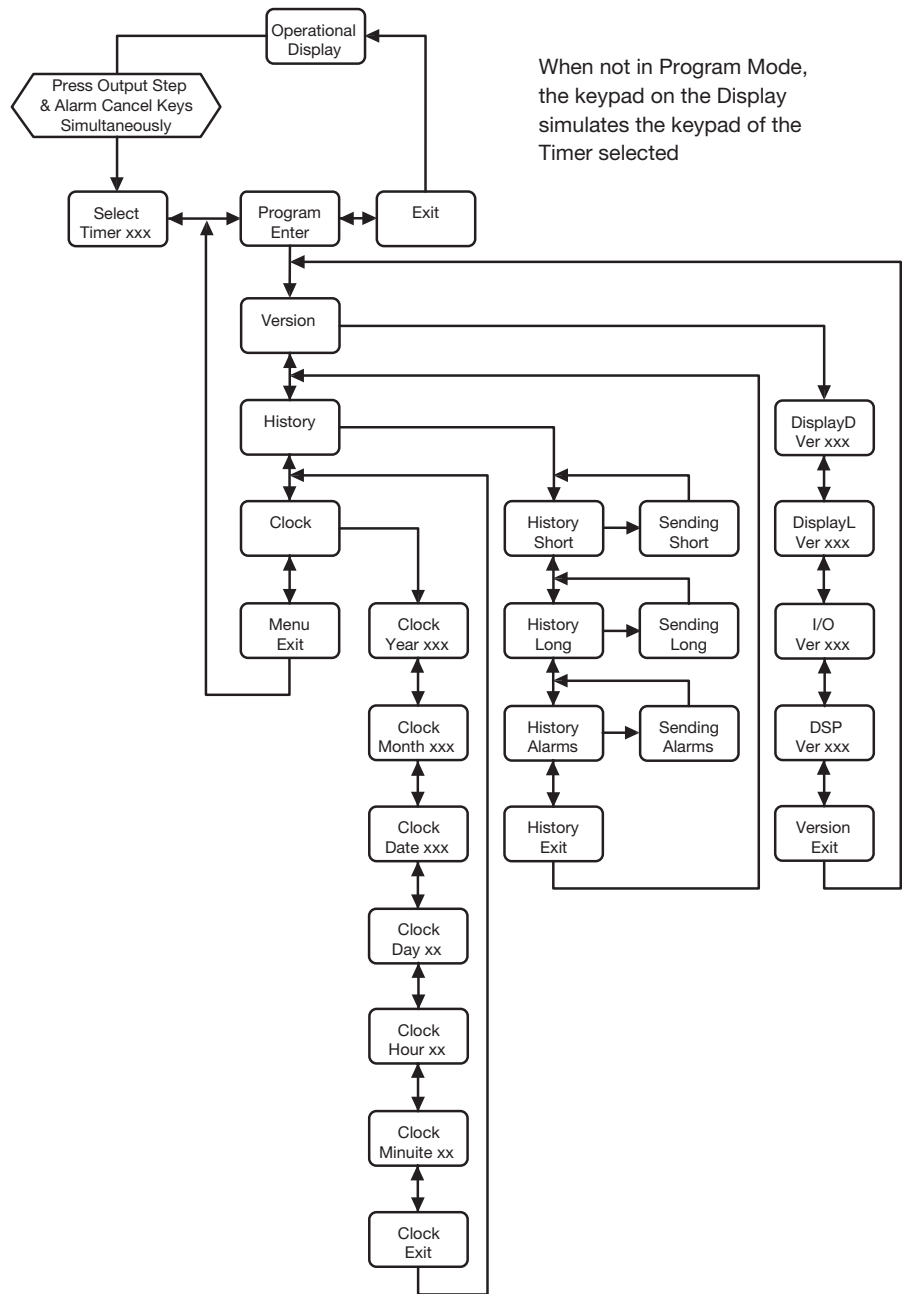

Display Keypad

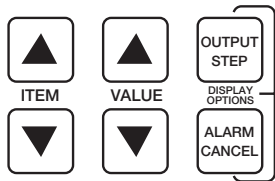

Use the ▲ and ▼ **Item Keys** to navigate within the Programming Tree. The ▲ Key moves up the Tree. The ▼ Key moves down the Tree.

Use the ▲ and ▼ **Value Keys** to select Program Options, or change parameters. The ▲ Key increments value. The ▼ Key decrements value

On/Off Switch

ORDERING INFORMATION

NEMA 4 Rated On/Off Switch with Legend Plate	MSW-0DPST-011
--	---------------

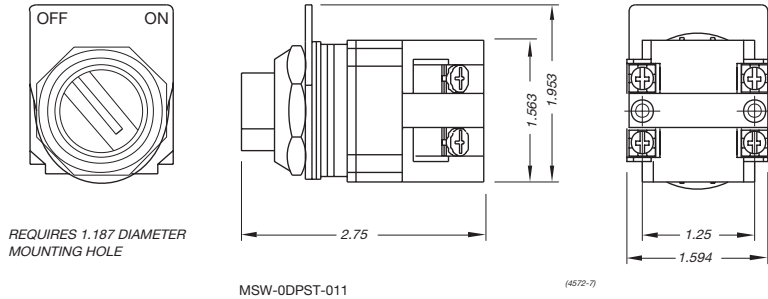

Pilot Lamp

ORDERING INFORMATION

NEMA 4 Rated Pilot Lamp	ASL-00RED-NEMA 4
-------------------------	------------------

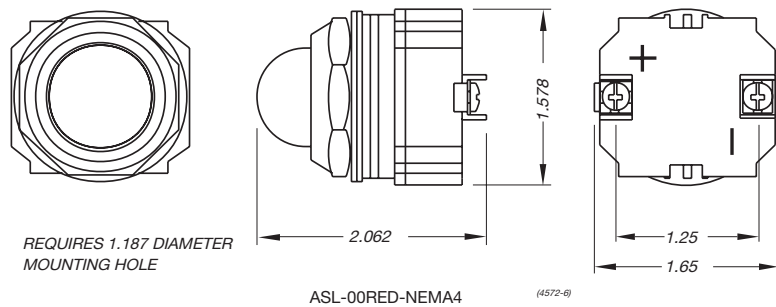

Relay

ORDERING INFORMATION

Alternate Action Dual Coil Latch Relay	KDD-LATCH-120AC
--	-----------------

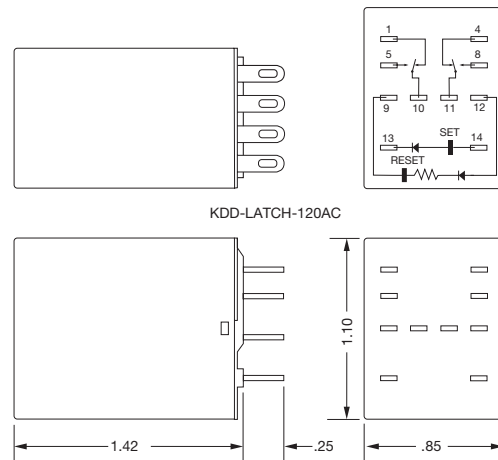

Socket

ORDERING INFORMATION

Socket for Latch Relay	MSO-0D11P-012
------------------------	---------------

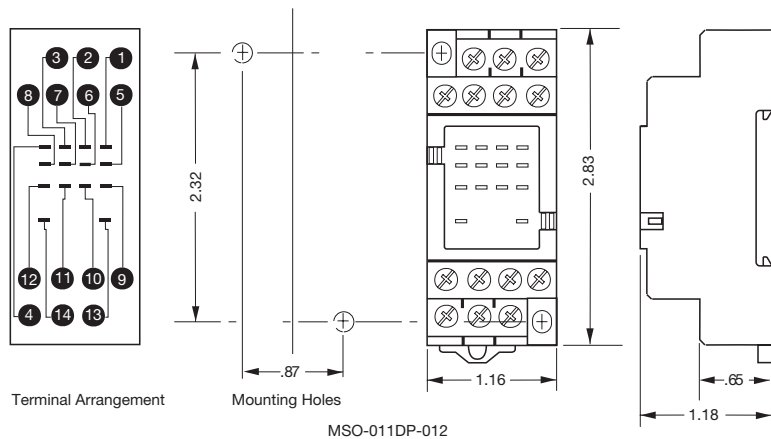

Enclosures

ORDERING INFORMATION

8" x 6" x 3.5" NEMA 4 Enclosure, Steel	BOX-A0806-CHNF
10" x 8" x 4" NEMA 4 Enclosure, Steel	BOX-A1008-CHNF
12" x 10" x 5" NEMA 4 Enclosure, Steel	BOX-A1210-CHNF
14" x 12" x 6" NEMA 4 Enclosure, Steel	BOX-A1412-CHNF
12" x 10" x 6" NEMA 4X Window Enclosure, Fiberglass	BOX-A1210-CHSC

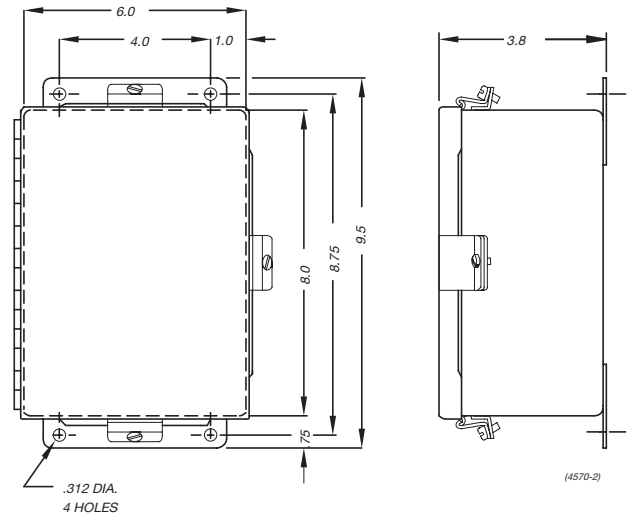

BOX-A0806-CHNF

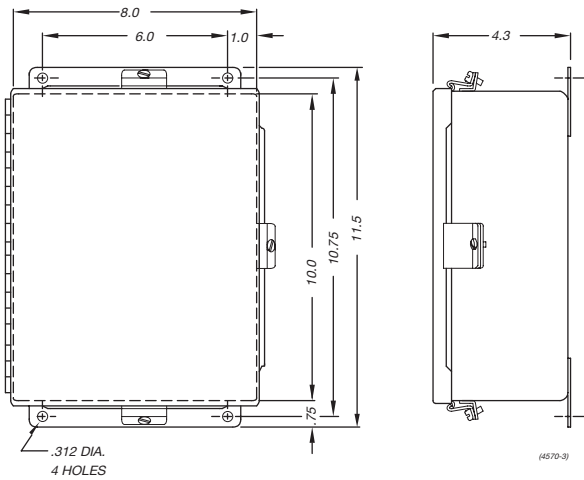

BOX-A1008-CHNF

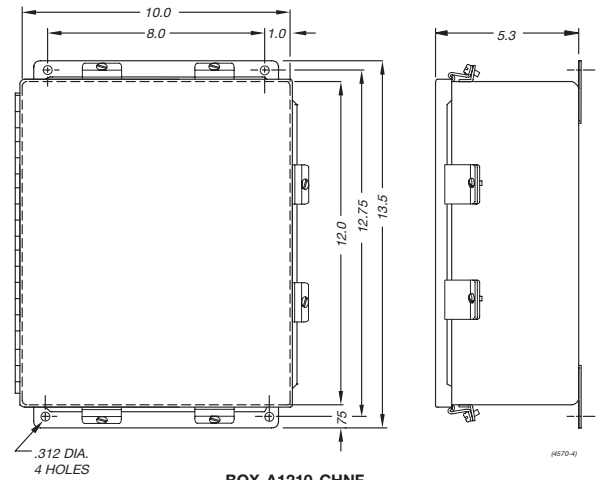

BOX-A1210-CHNF

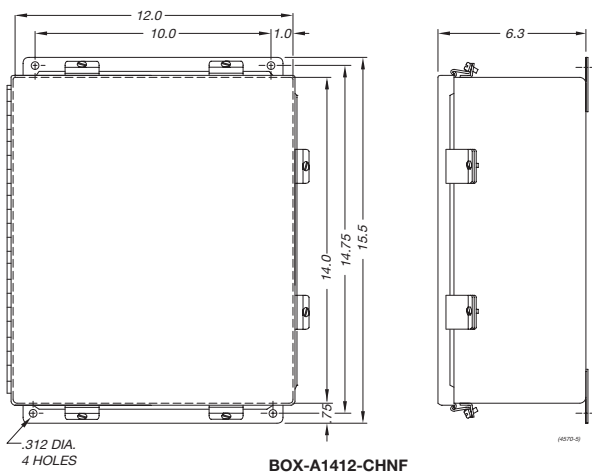

BOX-A1412-CHNF

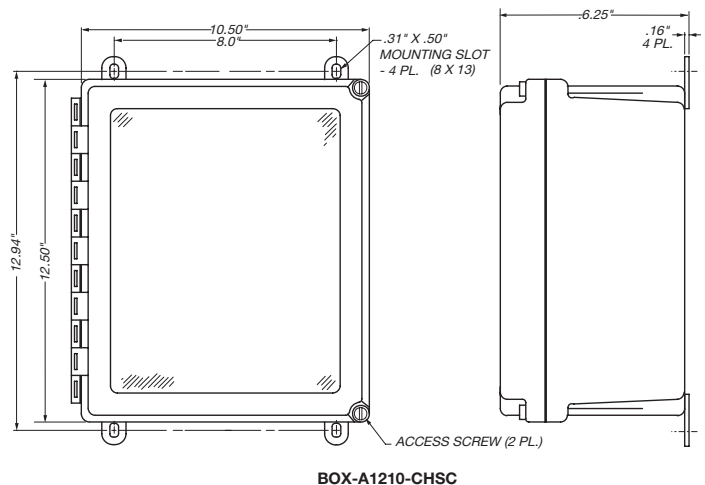

BOX-A1210-CHSC



AMETEK NCC offers a full line of Solid State Relays capable of switching from 10 to 75 A at up to 330 VAC 50/60 Hz. These rugged, encapsulated controls are ideal for use in applications which require a frequent switching rate and/or a high current inrush rate. Particularly, large tungsten lamp loads or motor loads are well served by solid state switching devices, as there are no moving parts to arc over and wear out. The reliability of AMETEK NCC's Solid State Relays has been time-tested in industrial environments throughout the world.

In addition to our Solid State Relay offering, AMETEK NCC provides a reliable, low cost means to monitor line voltage parameters in both single phase and 3 phase applications as well as over/under current monitoring of up to 20 A. Costly motor damage as well as sensitive equipment malfunction can be averted with the use of these line monitors which will steadfastly guard against low voltage and improper phase conditions.

In addition, at AMETEK NCC offers impressive factory back-up support, and our parts inventory and product availability are unsurpassed. With over 250 stocking distributor outlets, serious downtime problems can virtually be eliminated. Technical assistance for design and engineering help is readily available through our **toll free number: 800-323-2593.**

Common Applications:

- *3 Phase Motor Protection*
- *Compressor Brown Out Protection*
- *Elevator Protection*
- *Industrial Wastes Pump Monitor and Control*
- *Deep Well Pump Protection*
- *Large Incandescent Lamp Load Control*
- *Frequent Switching of Large Loads*
- *Motor Overload Protection*
- *Broken Drive Detection*

Solid State Power Relays

Model R2025

FEATURES

- CSA certified file #LR701222
- 100% functionally and surge tested
- 24 to 330 VAC load voltage
- 4000 V isolation
- Optically coupled
- Epoxy filled
- Capable of being switched by a single CMOS gate
- Built in snubber
- Capable of switching inductive loads of 0.5 power factor
- UL recognized component file #E164906

The AMETEK NCC Series of Solid State Power Relays provide a highly reliable means of switching a variety of AC loads up to 20 A. Snubber circuitry is included with each unit for high dV/dt applications and inductive loads.

Use of rugged output devices provides significant increases in turn-on surge capability. Two input control voltage ranges are available in either Form A (SPST-NO) or Form B (SPST-NC) output configurations.

SPECIFICATIONS

ALL MODELS

- Max. Load Current*:** 25 A
- Max. Peak Transient Voltage:** 600 Vpk
- Output Voltage Range:** 48-300 VAC
- Max. Off State Leakage Current:** 7.2 mA at 300 VAC (RMS)
- Operating Temp. Range:** -40 to 80 °C
- Storage Temp. Range:** -40 to 65 °C
- Dielectric Strength at 60 Hz**
Between Input/Output: 4000 VAC (RMS)
Between Input/Base: 2500 VAC (RMS)
Between Output/Base: 2500 VAC (RMS)
- Max. Surge Current:** 370 arms, 8.3 ms
- Min. Off State dV/dt (static):** 500 V/μS
- Thermal Resistance Junction to Case (Point A):** 1.3°C/W Tj max.=110 °C
- Turn On Type:** Random
- SNC-R2025-507 AND SNC-R2025-517**
- Max. On State Voltage Drop:** 1.5 VAC (RMS)
- Input Impedance:** 1700 ohms ±5%
- Turn Off Voltage:** 2 VAC/DC min.
- Turn On Voltage:** 3 VAC/DC max.
- Output Form:**
SNC-R2025-507: SPST-NO
SNC-R2025-517: SPST-NC
- Control Voltage Range:** 3-30 VAC/DC
- SNC-R2025-501 AND SNC-R2025-511**
- Max. On State Voltage Drop:** 1.65 VAC (RMS)
- Input Impedance:** 56 Kohms ±5%
- Turn Off Voltage:** 30 VAC/DC min.
- Turn On Voltage:** 70 VAC/DC max.
- Output Form:**
SNC-R2025-501: SPST-NO
SNC-R2025-511: SPST-NC
- Control Voltage Range:** 70-140 VAC/DC

* See derating curves for proper heat sink requirements

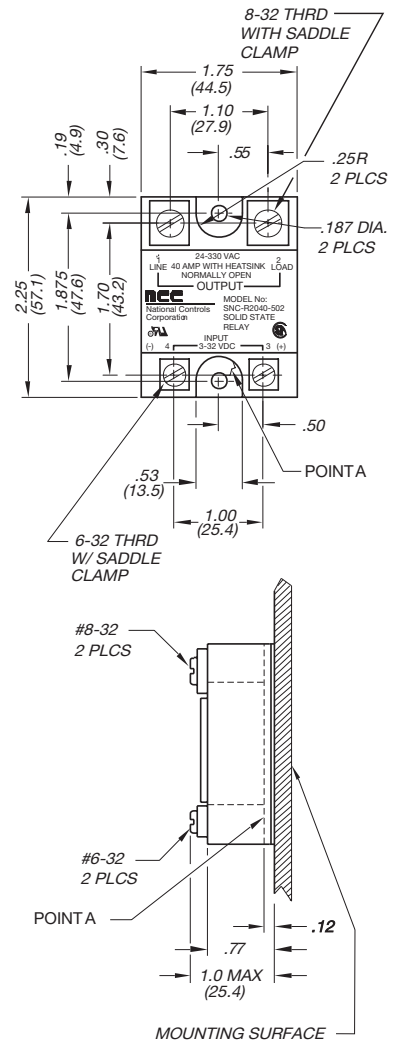

ORDERING INFORMATION

INPUT VOLTAGE	OUTPUT CONFIGURATION	PART NUMBER
3 to 30 VAC/DC	Normally Open, 25 A	SNC-R2025-507
7 to 140 VAC	Normally Open, 25 A	SNC-R2025-501
3 to 30 VAC/DC	Normally Closed, 25 A	SNC-R2025-517
7 to 140 VAC	Normally Closed, 25 A	SNC-R2025-511
ACCESSORY		PART NUMBER
Heatsink, .9 °C/W, supplied with Thermal Compound and Mounting Hardware		ASY-HS25A-011

Heat Sink Data

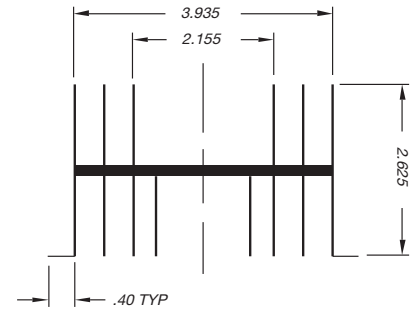
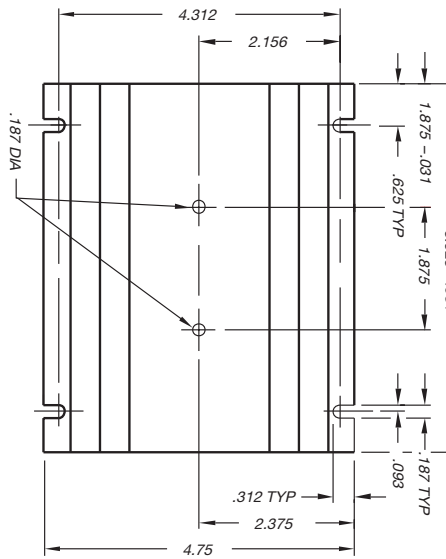
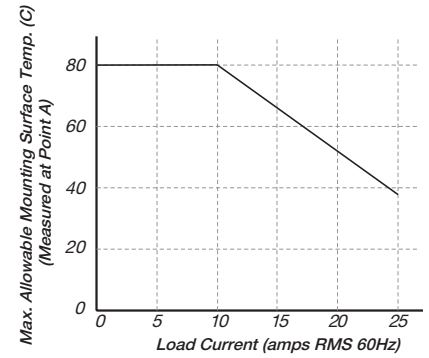
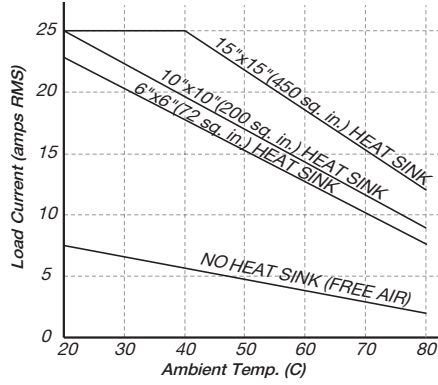

Heat sinks for derating curves are 1/8" thick aluminum with thermal compound between the mounting surface and solid state relay mounting plate.



3-Phase Voltage Monitor

Model 240T6

FEATURES

- 100% functionally tested
- Low cost
- Tri-color status LED
- 3 second fault delay timer
- Line voltage setpoint adjustment range: 160 VAC to 240 VAC
- 50/60 Hz operation
- SPDT 10 A relay output
- Convenient plug in package
-   File #E59090

Operating Logic: This control continuously monitors 3-phase power lines for abnormal conditions. When properly adjusted, the control will detect:

- Phase loss on a loaded motor, regardless of regenerated voltage
- Low voltage on all phases
- Very low voltage or loss of any single phase
- Phase reversal

If none of the above conditions are present, the control will energize the internal relay and the indicator light will be green. When any of the above faults are detected, the indicator light will turn yellow for approximately 3 seconds warning that the relay is about to de-energize. After the delay time the relay will de-energize and the indicator light will turn red. When the fault is corrected, the monitor will automatically reset by energizing the relay and the indicator lamp will be green. Should the fault be corrected during the delay time, the monitor will not de-activate the relay and the indicator will again be green.

Adjustment: Apply 3-phase power within operating range to the monitor (phase sequence must be observed). Turn adjustment to maximum clockwise position. Indicator lamp will be illuminated red after the delay time. Slowly turn counterclockwise until indicator changes to green (relay will activate). If voltage is nominal, setting should be correct.

Note: If phase sequence is incorrect, the monitor will not activate. Reverse any two input leads and readjust as described above.

SPECIFICATIONS

SETPOINT

Adjustment: Single turn potentiometer for adjusting nominal voltage

Range:

160-240 VAC 60 Hz LO to HI
180-240 VAC 50 Hz LO to HI

Accuracy:

Min. Setting (Max. CCW): Must operate (green light) at 160 VAC, 60 Hz (180 VAC, 50 Hz) line to line

Max. Setting (Max. CW): Must drop out (red light) at 240 VAC 50/60 Hz line to line

Hysteresis: 2% typical

Fault Delay Time: 2 to 4 sec.

INPUT

3 Phase Operating Voltage: Three wire connection, no neutral required

160-240 VAC, 277 VAC max. line to line 60 Hz
180-240 VAC, 277 VAC max. line to line 50 Hz

Power Consumption: 3 W max. at 277 VAC line to line exclusive of load

Frequency: 50/60 Hz

OUTPUT

Contact Type: Relay SPDT (1 form C)

Rating: 10 A max. resistive, 1/3 hp, 345 VA, 120/240 VAC

Life:

Mechanical: 10,000,000 operations
Full Load: 500,000 operations

Display: 1 tricolor LED

Green indicates status OK

Yellow indicates fault condition imminent

Red indicates fault condition

PROTECTION

Transient Voltage: protected by three 30 joule metal oxide varistors

Dielectric Breakdown: 1500 V RMS minimum at 60 Hz between input and outputs and between outputs

MECHANICAL

Termination: 8-pin plug

Mounting: Socket mount, part number MSO-0008P-012

ENVIRONMENTAL

Storage Temperature: -23°C to 70°C

Operating Temperature: -23°C to 55°C

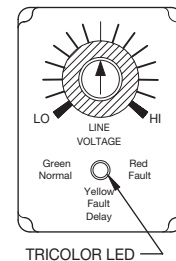

TRICOLOR LED

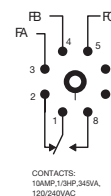
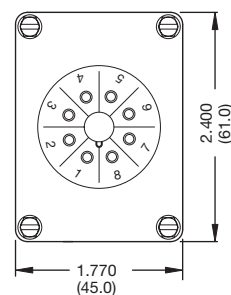
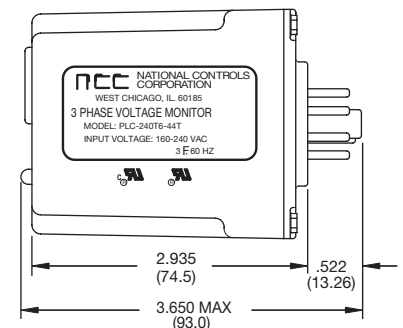

PIN CONFIGURATION

ORDERING INFORMATION

VOLTAGE RANGE	PART NUMBER
160 to 240 VAC	PLC-240T6-44T

ACCESSORY	PART NUMBER
8-pin circular socket, DIN rail mountable	MSO-0008P-012

Single-Phase Undervoltage Monitors

Models 120AZ and 240AZ

FEATURES

- 100% functionally tested
- Form C relay output
- On-board Trimpot for setpoint adjustment
- Circuitry completely encapsulated
- Low cost protection against brownouts
- Compact size
- Superior transient protection
- Flame-retardant and solvent-resistant polyester thermoplastic housing
- File #E65038

LOGIC FUNCTION DIAGRAM

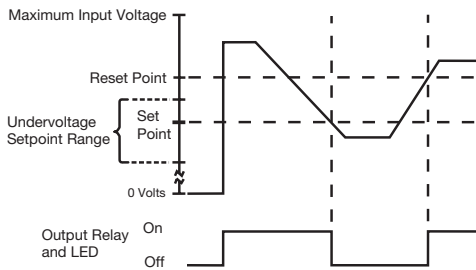

The 120AZ and 240AZ voltage sensors are intended for use as protection devices for electronic equipment in the event of a brown out condition.

Operating Logic: When the input voltage to the module is greater than the Reset Point voltage, the relay will be energized and the LED will be illuminated indicating a normal line voltage condition. If, however, the input voltage drops below the Setpoint Voltage selected by the potentiometer, the relay will de-energize and the LED will turn off. The module will remain in this state as long as the input is less than Reset Point voltage.

SPECIFICATIONS

INPUT

Operating Voltage Ranges:
Model 120AZ: 0 to 132 VAC 50/60 Hz
Model 240AZ: 0 to 264 VAC 50/60 Hz

Max. Power Consumption:
Model 120AZ: 2.6VA at 132 VAC
Model 240AZ: 4.5VA at 264 VAC

CONTROL

Adjustment: On-board Trimpot

Undervoltage Setpoint Range:

Model 120AZ: 78 to 99 VAC
Model 240AZ: 156 to 99 VAC

Reset Point Voltage:

Model 120AZ: 104 VAC
Model 240AZ: 209 VAC

Repeatability: ±0.5% for fixed conditions; ±1% over temperature range

Voltage Sense Accuracy: ±2% at 25°C

Power Off Reset Time: 150 ms max.

OUTPUT

Type: Relay contacts, SPDT (1 form C)

Rating: 8 A max. resistive at 250 VAC and 30 VDC; 100 mA at 5 VDC minimum load current

Indication: Green LED; ON for normal condition

PROTECTION

Transient Voltage: 30 joule metal oxide varistor

Dielectric breakdown: 3000 Vrms terminal to mounting/1500 Vrms input to output

Insulation resistance: 100 megohms min. between terminals and case

MECHANICAL

Termination: .25" x .032" male fast-on terminals

Mounting: Surface mount with one #8 screw

Life:

Mechanical: 10,000,000 cycles min.

Electrical: 100,000 cycles min.

ENVIRONMENTAL

Storage temperature: -40°C to 85°C

Operating temperature: -23°C to 55°C

Humidity: 95% relative max.

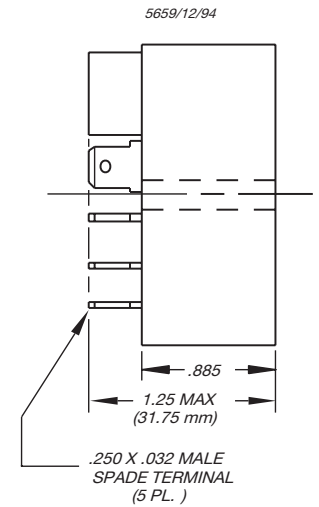
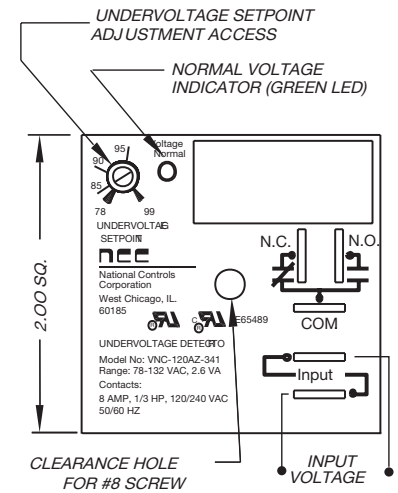

ORDERING INFORMATION

INPUT VOLTAGE RANGE	UNDERSIDE VIEW SETPOINT RANGE	RESET POINT VOLTAGE	PART NUMBER
0 to 132 VAC 50/60 Hz	78 to 99 VAC	104 VAC	VNC-120AZ-341
0 to 264 VAC 50/60 Hz	156 to 199 VAC	209 VAC	VNC-240AZ-345

2-20 A Current Monitor IST-200T Series

FEATURES

- 100% functionally tested
- Low cost
- Fault status LED
- Adjustable trip delay timer
- Adjustable trip point from 2 to 20 A
- Selectable output modes:
 - Latching
 - Non-latching
- Selectable sensing modes:
 - Over-current
 - Under-current
- 120 VAC and 240 VAC models
- 50/60 Hz operation
- SPDT 10 A relay output
- Epoxy encapsulated
-  File #E59090

Operating Logic: The Current Monitor senses AC load current passing through its torroid transformer. In the OVER-CURRENT mode, the on-board relay will initiate the TRIP DELAY timer and illuminate the FAULT LED when the sensed current is greater than the TRIP POINT setting. If the sensed current is still greater than the TRIP POINT setting after the TRIP DELAY timer has elapsed, the on-board relay will energize.

If the UNDER-CURRENT mode is selected, the on-board relay will be un-energized as long as the sensed current is greater than the TRIP POINT setting. Once the sensed current drops below the TRIP POINT setting, the TRIP DELAY timer will start timing and the FAULT LED will illuminate. If the sensed current is still less than the TRIP POINT setting after the TRIP DELAY time has elapsed, the on-board relay will energize and its contacts will change state.

The Current Monitor will automatically reset itself when the sensed current returns to its non-fault value if the NON-LATCH mode is selected. However, if the LATCH mode is selected, the on-board relay will remain energized regardless of any subsequent change in the sensed current. To reset the fault in this mode, either remove input power from unit and reapply it, or switch to NON-LATCH mode.

The Current Monitor is designed to sense a range of 2 to 20 A with a single loop of the load wire passed through the torroid transformer. Greater sensitivity can be achieved by passing multiple loops of the load wire

through the torroid transformer; two turns would change the range to 1 to 10 A, four turns would change it to 0.5 to 5 A.

TYPICAL APPLICATION

As long as the operating current of the motor is less than 10 A, the alarm will not sound. If the motor draws greater than 10 A for longer than 4.5 seconds, the FAULT LED will light and the alarm will sound. Because the NON-LATCH mode is set, the fault condition will clear as soon as the current draw of the motor drops below 10 A. When the fault is cleared, the FAULT LED will turn off and the alarm will stop sounding. If, however, the LATCH mode was selected and an OVER-CURRENT fault is detected, the fault will not clear when the motor current draw dropped below 10 A. In this case, the alarm would continue to sound until reset of the Current Sensor by either removing and reapplying power or by switching to NON-LATCH mode.

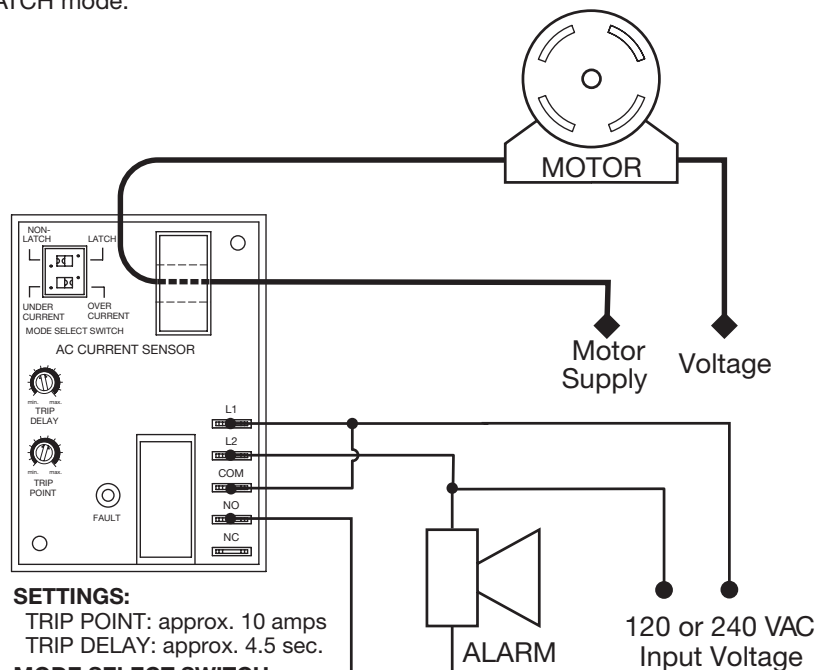

SETTINGS:
TRIP POINT: approx. 10 amps
TRIP DELAY: approx. 4.5 sec.

MODE SELECT SWITCH:
Non-Latching
Over-Current

SPECIFICATIONS

INPUT

Operating Voltage:

IST-200TA-141: 105 to 135 VAC, 50/60 Hz
IST-200TA-145: 210 to 270 VAC, 50/60 Hz

Power Consumption: 3.5 VA max.

Current Sense Input: 0 to 40 A steady-state
200 A inrush for 100 ms max.

OUTPUT

Type: Relay contacts SPST (1 form C)

Rating: 10 A resistive, 1/2 hp at 250 VAC

Life:

Mechanical: 1,000,000 operations

Electrical: 100,000 operations at full load

CURRENT SENSE ADJUSTMENT

Range: 2 to 20 A with single load wire through sensor, Trimpot adjustable

Power-up surge delay: 100 ms max.

Response time: 100 ms max. over or under current mode

CURRENT TRIP DELAY ADJUSTMENT

Range: 0.1 to 10 sec., Trimpot adjustable

MECHANICAL

Termination: 5 - .25" x .032" male fast-on terminals

Mounting: 3.5" x 2.5" encapsulated enclosure with 2 mounting holes suitable for #8 screw

ENVIRONMENTAL

Storage Temperature: -40°C to +85°C

Operating Temperature: -40°C to +65°C

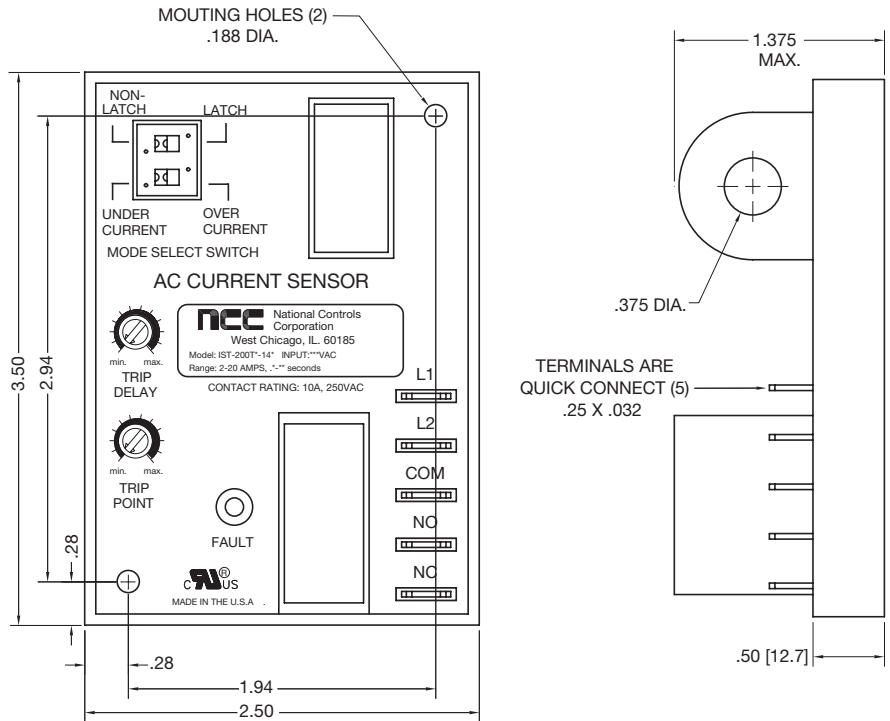

ORDERING INFORMATION

INPUT VOLTAGE	TRIP POINT	TRIP DELAY	PART NUMBER
120 VAC	2 to 20 A	.1 to 10 sec.	IST-200TA-141
240 VAC	2 to 20 A	.1 to 10 sec.	IST-200TA-145

AC (Alternating Current) An electric current that reverses direction in a circuit at regular intervals.

Accuracy The variation between the specified delay time and the Actual Time value, given in percent of specified delay. $[(\text{Actual Time} - \text{Specified Delay Time}) / \text{Specified Delay Time}] \times 100$.

Actual Time The actual delay of a given device with sufficient OFF time to input voltage to permit full recovery of the timing interval. The resulting average of a group of consecutive time delay readings (excluding the first) may be used to determine the Actual Time. Five cycles should be considered adequate for the determination.

Ambient Temperature Temperature of the air which encircles an object.

Ampere (Amp) The basic unit of electric current.

Arc A luminous discharge of electric current crossing a gap between two electrodes either through the air or over an insulated surface. It is deleterious to electromechanical switches, limiting contact life.

Break The moment and/or location at which a series circuit is opened and made discontinuous.

Brownout A condition in which the supply voltage is insufficient to power the load.

Circuit A closed path followed or capable of being followed by an electric current.

Closure The moment and/or location at which two contacts meet to complete a circuit.

Conductor A substance or medium that conducts heat, light, sound, or especially an electric current.

Contact Chatter (Contact Bounce) Occurs when an electromechanical switch is in the process of making connection in a circuit; for a brief time period, the contacts will bounce together until they are fully seated.

Contacts Electromechanical components that make or break a connection between two conductors that permit a flow of current.

Controller A regulating mechanism, as in an electric device used to control a particular process based on input parameters.

CSA Canadian Standards Association (Testing Laboratory for products sold in Canada.)

Current The amount of electric charge moving in a conductor past a specified circuit point within a given time. The basic unit is the ampere.

Cycle A single complete execution of a periodically repeated event or a periodically repeated sequence of events.

De-energize To remove power from a device.

Delay To postpone an event until a later time.

Delay On Break (Off Delay) A particular type of timing function whereby the OFF event is delayed after a start circuit is opened.

Delay on Make (Delay On Energize, On Delay) A particular type of time function which delays the ON event upon initial application of power to the timing device.

Dielectric Breakdown The voltage potential at which the insulating properties of a non-conductor will break down and conduct current. Measured in Kilovolts.

DC (Direct Current) An electric current flowing in one direction (constant polarity), as opposed to Alternating Current.

DPDT (Double Pole Double Throw 2 Form C Contacts) A type of contact configuration which consists of two isolated sets of contacts operating simultaneously. Each contact set consists of a Common contact, Normally Open contact, and a Normally Closed contact. In relay nomenclature, the states of the contacts are given with the relay coil unenergized.

Electricity A basic phenomenon in nature which involves the movement of electrons in a medium. This movement of electrons or electric current is considered a source of power.

Electromotive Force (EMF) Difference in electrical potential measured in volts.

Encapsulant A compound, typically epoxy or silicone elastomer, used to envelop and seal components in an electronic circuit.

Energize To apply power to a device.

External Adjustment A remotely located component or device which is used to alter an input or output parameter on a controller.

Factory Calibration To adjust a controller during the manufacturing process to specific points in order to meet the operational specifications.

Factory Fixed Fixing a particular control parameter during the manufacturing process to make it non-adjustable in the field.

Frequency The number of repetitions within a given time of a complete wave form, as of common line voltage with typical frequencies of 50 or 60 cycles per second. See *Hertz*.

Full-wave Rectified AC Alternating Current changed to Direct Current utilizing both the positive and negative portions of the AC sine wave.

Ground The point of an electric circuit that is at a zero volt potential with respect to the earth.

Guaranteed Range The range of operation of a controller or controlled parameter which the manufacturer specifies reliable consistent operation.

Half-wave Rectified AC Alternating Current changed to Direct Current utilizing only the positive or negative portion (not both) of the AC sine wave.

Heat Dissipation Because all electrical devices offer resistance to the flow of current, heat is generated when current flows through this resistance. This undesired heating effect is a function of the device resistance and the amount of current flowing through it. Heat sinks are used to cool high current devices, thereby dissipating the heat generated.

Heat Sink A device which possesses low thermal resistance in order to effectively absorb and dissipate heat.

Heat Sink Compound A compound used to assure good thermal connection between a heat dissipating device and a heat sink.

Hertz A unit of frequency named after Heinrich R. Hertz (1857-1894) which is equal to one cycle per second.

Holding Current In solid state switching devices there is a point at which the current flow is insufficient to maintain conduction. Holding current is specified as the minimum current through the device, across the operating temperature range, that will maintain conduction.

Horsepower (hp) A unit of power in the U.S. Customary System, equal to 745.7 watts or 33,000 foot-pounds per minute. Electrical motors are rated in horsepower, so accordingly, devices designed to control motors are also rated in horsepower.

Humidity Water vapor content in the air. In percent Relative Humidity, it is a measurement of the actual water vapor content of a unit volume relative to what the maximum amount of water vapor the same volume can contain at a given temperature.

Hysteresis The failure of a property that has been changed by an outside force to return to its original value when the cause of the change is removed. Some hysteresis is designed into controller circuits because it prevents noise from causing false triggering.

Incandescent Load From a switching perspective, the incandescent load represents an initial inrush current of up to 10 times the steady state rating.

Inductive Load An inductive load opposes any change to circuit current. Devices such as motors, solenoids, relay coils, valves, and contactor coils are all inherently inductive loads. The current waveform is always lagging the voltage waveform in an inductive load; because of the phenomena, certain factors must be taken into account when working with this type of load. An inductive load can exhibit an inrush current of up to 5 times its normal running or steady state current when energized. When power is removed from the inductive load, high voltage transients are generated due to the collapsing magnetic field, and this can cause arcing across contacts or a malfunction, and/or damage to electronic circuits.

Initiate Time (Start Time) The minimum time of a switch closure or voltage pulse applied to a start switch input of a controller which will activate the control function.

Input Voltage The voltage source applied to the controller input terminals which is used to power the controller while it is performing its function.

Inrush Current The peak value of current which a load requires when first being energized. Certain types of loads (e.g., lamps, motors) will draw a larger initial current because their impedance is lower at startup than during steady state operation.

Isolation No electrical connection between two or more circuits.

Insulation Resistance The degree of non-conductance of an insulator, measured in Megohms.

Insulator A material that insulates, particularly a nonconductor of electricity, heat, or sound.

Interval A period of time between events.

Kilohm One thousand ohms (1,000 or 1 K ohms).

Leakage Current The maximum current which a solid state device still conducts when in the OFF state. Leakage current is usually measured in milliamperes (mA).

LED Light Emitting Diode, used in information displays and as status indicators.

Life A specific number of operations or amount of time during which a particular device is expected to operated reliably.

Line Frequency Frequency of electrical service provided by local utility, typically 50 or 60 Hertz.

Line Voltage Initiation The initiation of a control function by application of line voltage to either the controller's input terminals or start switch terminals.

Line Voltage Nominal voltage of electric service provided by local utility, typically 120 or 240 VAC.

Load Any device which consumes power to do work.

Load Rating A specification of the output capability of a particular controller. Typically parameters for load rating are: controllable current range, maximum AC and/or DC voltage, horsepower or Power Factor and maximum inrush current.

Lock Shaft (Locking Bushing) A mechanical means to inhibit further adjustment of a rotary type device such as a potentiometer.

Low Voltage Voltage which is typically less than 30 Vrms.

Magnal Plug A circular, 11-pin male connector with an indexing key for proper orientation in the mating socket.

Make A term used to denote the action of completing an electrical circuit.

Metal Oxide Varistor (MOV) A device whose impedance decreases dramatically when subjected to voltages greater than the rated clamping voltage. It is typically placed in parallel with the input and/or output of a switching device to effectively clamp transient voltage spikes to a certain level.

Megohm One million ohms (1,000,000 or 1Meg ohms).

Micro A metric prefix which is used to multiply a standard unit by 10^{-6}

Milli A metric prefix which is used to multiply a standard unit by 10^{-3}

Milliamperes One-one thousandth of an ampere (.001 or 10^{-3} ampere).

Ms One one-thousandth of a second (.001 or 10^{-3} second).

Minimum Load Current For electro-mechanical contacts, it is the minimum current the contacts will reliably switch without the contact resistance contributing a substantial error in the circuit. See *Holding current*.

Mode of Operation Logical function of a controller based on input parameters.

Momentary Initiation The initiation of a controller cycle by a start pulse of shorter duration than the complete cycle. The initiation could be with a momentary contact closure or voltage pulse.

Momentary Loss of Power A short removal of input power to the controller or controlled circuit. See *Brownout*.

Momentary Switch A spring loaded set of contacts, that when the actuator is pressed, the contacts either close or open depending on contact configuration. When the actuator is released the contacts will resume their normal state.

MOV Metal oxide varistor.

Noise An undesirable electrical phenomenon which is generated by various means (e.g., switching large loads, light dimmers, electrical storms). This phenomenon consists of random voltages and currents induced into electrical circuits, if severe enough, erratic operation of these circuits can result.

Nominal Voltage The middle point of two extremes of voltage as defined by the tolerance.

Normally Closed Contact (NC) The condition or position of a particular contact with respect to a common contact in its normal or quiescent (unenergized) state. A normally closed contact represents a closed circuit.

Normally Open Contact (NO) The condition or position of a particular contact with respect to a common contact in its normal or quiescent (unenergized) state. A normally open contact represents an open circuit.

Octal Plug A circular 8-pin male connector with an indexing key for proper orientation in the mating socket.

Offset A fixed difference between the controller setpoint and the actual control point of a system under stable operating conditions.

Ohm A unit of electrical resistance and impedance named after Georg S. Ohm. A conductor has a resistance of one ohm when a current of one ampere flows through it with a potential of one volt across its terminals.

ON/OFF Time Ratio The ratio of ON time to OFF time specified as a fraction or percentage of the total period.

On State Voltage The voltage measured across a solid state output device when it is in the ON state. For all practical considerations the value is the same for Peak or RMS measurements. NOTE: The portion of the sine wave before the solid state device turns ON is not to be included in this measurement.

Operating Temperature The range of ambient temperature in which a controller is designed to operate within its specifications. May be stated in Fahrenheit or Celsius.

Operating Voltage The range of input voltage within which a controller is designed to operate. Usually, it is stated as a nominal value with a maximum and minimum tolerance (e.g., 120 VAC $\pm 10\%$).

Optical Isolation Utilizing light to isolate one control circuit from another; mainly used to safely interface a low level control signal with a high power output, as in a solid state relay.

Output The result delivered by a circuit or device. Also, the terminal or other location where such result is delivered.

Parallel A type of circuit connection in which loads are connected side by side across a common voltage source.

Phase The instantaneous angular position which a sine wave occupies in its cycle. The position is usually measured in degrees as referenced to zero and referred to as phase angle.

Polarity The positive and negative orientation of a source of power or signal.

Potential Difference The voltage differential between two points.

Potentiometer (POT) A three terminal device which consists of a fixed resistor with terminations on each and a moveable contact (wiper) that can travel between the two terminations. Also called a variable resistor.

Power In a Direct Current circuit it is the product of applied potential difference and current. In an Alternating Current circuit it is the product of the effective values of the voltage and current with the cosine of the phase angle between current and voltage. The units of measurement are VA or watt.

Power Factor The ratio of true power to apparent power in an alternating current, or a ratio of resistance to impedance.

Quick Connect Terminals (Fast-on) A solderless friction type termination used in industrial controls to facilitate field wiring of electrical control systems.

RC Resistor/capacitor network. See also *Snubber Network*.

Rectifier (Diode) An electronic device which allows current to flow in only one direction. It is used to convert AC to DC.

Repeatability (Repeat Accuracy) The percent variation of time within a group of consecutive timing cycles, starting with the second operation, when the timing device is operated under constant conditions of operating voltage, ambient temperature, and ON/OFF times.

Reset Time The time a controller takes to return to its initial parameters when input power is removed.

Resistance The opposition to electric current flow. All conductors offer some resistance and the basic unit of resistance is the ohm.

Resolution The degree of accuracy to which a controller can be set to or the degree of accuracy of an output function, as in a digital readout of a specific output.

Rheostat A variable resistor having one moveable contact (wiper), and one terminal fixed at one end of the resistance. A potentiometer can be connected as rheostat by connecting the wiper to either one of its other terminals.

RMS (Root Mean Square) Effective DC value of sinewave voltage or current. The effective value is .707 times the peak voltage or peak current measured.

Series Circuit Loads connected end to end across a voltage source.

Set Point The point at which a controller will perform a function. The setpoint can be either factory fixed or user adjustable as in a temperature controller or a timer.

Setting Accuracy The degree of accuracy (resolution) to which a controller setpoint can be adjusted.

Shunt A low-resistance connection between two points in an electric circuit that forms another path for a large portion of the current.

SPDT (Single Pole Double Throw) A type of contact configuration which consists of a Common contact, Normally Open contact, and Normally Closed contact. In relay nomenclature, the states of the contacts are given with the relay coil unenergized.

Snubber Network Typically, a series connection of a resistor and capacitor applied across an output device (especially solid state) to minimize voltage spikes due to line transients or load switching. It is used to help prevent unwanted switching of solid state devices and arcing of mechanical contacts.

Specified Delay Time The advertised time, design print specified time, or set time of the delay function.

Steady State The condition of a device after power has been initially applied for a certain period, or when its electrical parameters are allowed to stabilize. This condition is reflected in parameters such as current flow, output voltage, and/or temperature.

Storage Temperature The range of ambient temperatures in which a controller is designed to be stored, in order to assure operation within its specifications. May be stated in Fahrenheit or Celsius.

Termination The point at which electrical devices are connected to field wiring of either inputs or outputs. Typical types of termination are: Quick connect terminals, screw terminals, flying leads, etc.

Time Diagram A logic function drawing used to relate the output operation of a particular controller with regard to its input parameters over a given period of time.

Tolerance The permissible deviation from a specified value of an electrical parameter. Normally stated as a percentage of a nominal value.

Transient A momentary occurrence of a particular phenomenon.

Transient Voltage Voltage spikes of short duration which occur in electrical circuits that exceed the normal designed operating levels. Two main types of voltage transient wave forms are generally used by the industry to define the typical transients found in the field. They are defined in the IEEE C62.41 standard *IEEE Recommended Practice on Surge Voltages in Low Voltage AC Power Circuits*. Transient surges considered in this section do not exceed one-half period of the applied AC line frequency. Also, the magnitude of the crest voltage and current are designated as a peak open circuit voltage of 6 kV and a peak short circuit current of 3 kA. Of the two, the one which simulates lightning transients is the combination 8/20 μ S current and 1.25/50 μ S voltage wave form. The simulation of transients generated by switching large capacitive or inductive loads is represented by a 0.5 μ S –100 kHz ring wave.

Underwriter's Laboratories Inc. (UL) Testing agency for products sold in the United States.

Volt The basic unit electromotive force or potential difference.

Voltage The difference in electrical potential, or electromotive force between the terminals of a source of electricity. It is usually measure in volts.

Voltage Drop See *On State Voltage*.

Watt The basic unit of power.

ORDERING INFORMATION

How to Order

All of our standard industrial products are available through a national distributor network. For the name of our nearest stocking distributor, please call AMETEK NCC's **Customer Service Department** at 630-231-5900 or toll-free 800-323-2593.

If you do not find the product you are looking for in our catalog, or you are unsure of what you need to fit your application, just call us for technical assistance – we'll be glad to help.

Our Warranty Policy

AMETEK NATIONAL CONTROLS CORPORATION warrants its products for a period of one (1) year from date of receipt by user, but in no event more than eighteen (18) months from date of manufacture, Against defective material or workmanship, but not against damage caused by accident, abuse, faulty installation, or improper application or operation. Probes are warranted for (90) ninety days.

During this period, AMETEK NCC will, at its option, repair or replace defective products returned, transportation charges prepaid, to its factory.

AMETEK NCC shall not be liable for any indirect or consequential damages. To the extent permitted by law, this is given in lieu of all other warranties expressed or implied, and AMETEK NCC neither assumes nor authorizes any person to assume for it any liability beyond stated herein.



1725 Western Drive
West Chicago, Illinois 60185
Tel: 800-323-2593 • 630-231-5900
FAX: 630-231-1377

www.nationalcontrols.com