

**Part Number:** [0640030100](#)  
**Status:** **Active**  
**Description:** Hand Crimp Tool

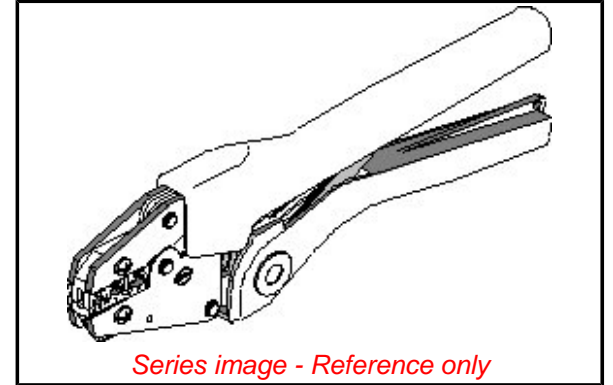

**General**

Product Family	Application Tooling
Series	<u>T0102</u>
Function	Crimp
Geographic Area	Global
Level of Automation	Manual

Product Name	N/A
--------------	-----

Tool Type	Handtool
-----------	----------

**Material Info**

Old Part Number	RHT-1992
-----------------	----------

**EU RoHS**

**RoHS Compliance  
Not Required**

**China RoHS**



## FEATURES

- A full cycle ratcheting hand tool ensures complete crimps
- Long handles for comfortable crimping with reduced crimping force
- A precision user-friendly terminal locator / wire stop holds terminals in the proper crimping position for each of the three nests
- 3-nested tool eliminates the need for additional tools

## Hand Crimp Tool Operating Instruction and Specifications Sheet Order No. 64003-0100 Eng. No. RHT 1992 (Replaces 19284-0014)

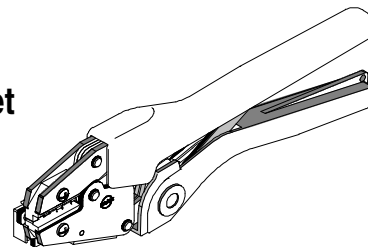

## SCOPE

Products: Krimptite™ / VersaKrimp™ Terminals and Splices 10–22 AWG.

## Testing

### Mechanical

The tensile test, or pull test is, a means of evaluating the mechanical properties of the crimped connections. The following charts show the UL and Government specifications (MIL-T-7928) for various wire sizes. The tensile strength is shown in pounds and indicating the minimum acceptable force to break or separate the terminal from the conductor.

Wire Size (AWG)	*UL - 486 A	*UL - 486 C	**Military
22	8	8	15
20	13	10	19
18	20	10	38
16	30	15	50
14	50	25	70
12	70	35	110
10	80	40	150

\*UL - 486 A - Terminals (Copper conductors only)

\*UL - 486 C - Butt Splices, Parallel Splices

\*\*Military – Military Approved Terminals only as listed

The following is a partial list of the product part numbers and their specifications that this tool is designed to run.

Wire Size: 18 – 22 AWG 0.80 – 0.35 mm <sup>2</sup>			
Terminal No.	Terminal Eng No. (REF)	Wire Strip Length	
		In	mm
19022-0004	AMCT-1	0.281	7.137
19033-0001	A-159	0.281	7.137
19033-0003	A-169	0.281	7.137
19041-0005	A-142-10	0.281	7.137
19044-0034	A-120-04	0.281	7.137
19044-0063	A-120-02	0.281	7.137
19044-0066	A-120-06	0.281	7.137

Wire Size: 18 – 22 AWG 0.80 – 0.35 mm <sup>2</sup>			
Terminal No.	Terminal Eng No. (REF)	Wire Strip Length	
		In	mm
19044-0068	A-121-06	0.281	7.137
19044-0069	A-121-08	0.281	7.137
19044-0070	A-121-08R90	0.281	7.137
19044-0072	A-121-10	0.281	7.137
19044-0074	A-122-10	0.281	7.137
19044-0075	A-122-14	0.281	7.137
19044-0078	A-126-10	0.281	7.137

**PARTS LIST**

Item	Order No	Description	Quantity
	<b>64003-0100</b>	<b>Hand Crimp Tool</b>	<b>(Fig. 8)</b>
1	64000-0076	Repair Kit (Springs, Pins and E-	1
2	63810-0000	Handle	1
3	64007-0375	Locator Assembly	1
4	64003-0170	Tooling Kit	1
<b>Tooling Kit Only</b>			
5	64003-0102	Conductor Anvil	1
6	64003-0101	Conductor Punch	1

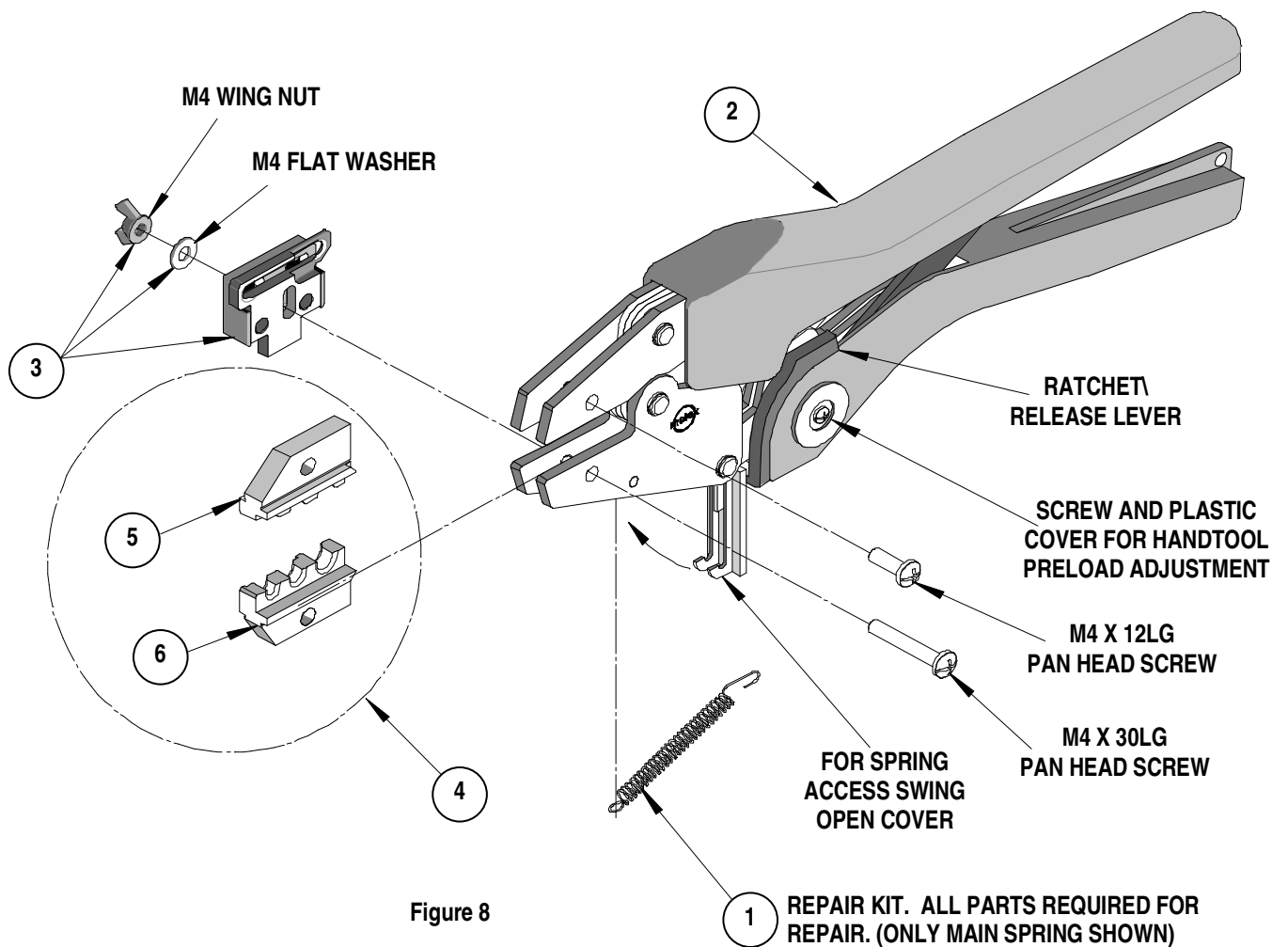

Figure 8