

Switch Language

English

Need Assistance?

- Contact Us
- Find a Distributor
- Order Samples
- Tech Library

[Printer-friendly page](#)

[Email this page](#)

[Home](#) [PCB Headers](#) [Datasheet](#)

Part Number: 0039281023

Status: Active **Overview:** [Mini-Fit Jr.™](#)

Description: 4.20mm (.165") Pitch Mini-Fit Jr.™ Header, Dual Row, Vertical, without Snap-in Plastic Peg PCB Lock, 2 Circuits, PA Polyamide Nylon 6/6 94V-2, Tin (Sn) Plating, without Drain Holes

Documents:

Note - Please disable browser pop-up blockers for documents on www.molex.com

- [Drawing \(PDF\)](#) [Product Specification PS-5557-003 \(PDF\)](#)
- [Product Specification PS-5557-015 \(PDF\)](#) [3D Model](#)
- [Related Catalog Page \(PDF\)](#)

Order Products:

- [Check Distributor Inventory](#) [Add to My Parts](#)
- [Request Samples](#)

Part Detail: [\(show all\)](#)

[General](#) [Physical](#) [Electrical](#) [Material Info](#)

General

Product Family	PCB Headers
Series	5566
Application	Wire-to-Board
Comments	Glow Wire Equivalent Part Number 50361882
Overview	Square Pin, Solder Type
Product Name	Mini-Fit Jr.™

Physical

Breakaway	No
Circuits (Loaded)	2
Circuits (maximum)	2
Color - Resin	Natural
Durability (mating cycles) min	30 cycles
First Mate / Last Break	No
Flammability	94V-0
Flammability	94V-2
Guide to Mating Part	No
Keying to mating part	None
Lock to Mating Part	Yes
Material - Metal	Brass
Material - Plating Mating	Tin
Material - Plating Termination	Tin
Material - Resin	Nylon
Number of Rows	2
Orientation	Vertical
PC Tail Length (in)	0.138 In
PC Tail Length (mm)	3.50 mm
PCB Locator	Yes
PCB Retention	None
PCB Thickness Recommended (in)	0.070 In
PCB Thickness Recommended (mm)	1.80 mm

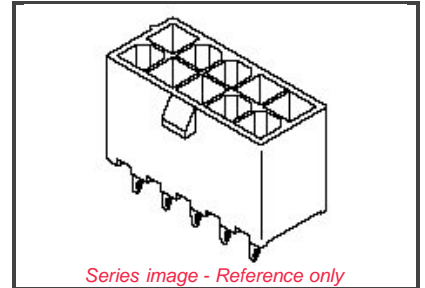

EU RoHS **China RoHS**
ELV and RoHS Compliant



Need more information on product compliance?

Email productcompliance@molex.com

Please visit the [Contact Us](#) section for any non-product compliance questions.

Search Parts in this Series

[5566](#) Series

Mates With

[5557](#) Mini-Fit Jr.™ Receptacle Housing

Packaging Type	Tray
Pitch - Mating Interface (in)	0.165 In
Pitch - Mating Interface (mm)	4.20 mm
Pitch - Term. Interface (in)	0.165 In
Pitch - Term. Interface (mm)	4.20 mm
Plating min: Mating (uin)	35
Plating min: Mating (um)	0.90
Plating min: Termination (uin)	100
Plating min: Termination (um)	2.50
Polarized to Mating Part	Yes
Polarized to PCB	Yes
Robotic Placement	None
Shrouded	Fully
Stackable	No
Surface Mount Compatible (SMC)	No
Temperature Range - Operating	-40°C to +105°C
Termination Interface: Style	Through Hole

Electrical

CSA	LR19980
Current - Maximum	9.000 Amp
TUV	R75142
UL	E29179
Voltage - Maximum	600V

Material Info

Old Part Number	5566-02A
-----------------	----------

Reference - Drawing Numbers

Product Specification	PS-5557-003
Product Specification	PS-5557-015
Sales Drawing	SD-5566-002
Sales Drawing	SD-5566-003
Sales Drawing	SD-5566-N***-*
Sales Drawing	SD-5566-NA**-*

10 9 8 7 6 5 4 3 2 1

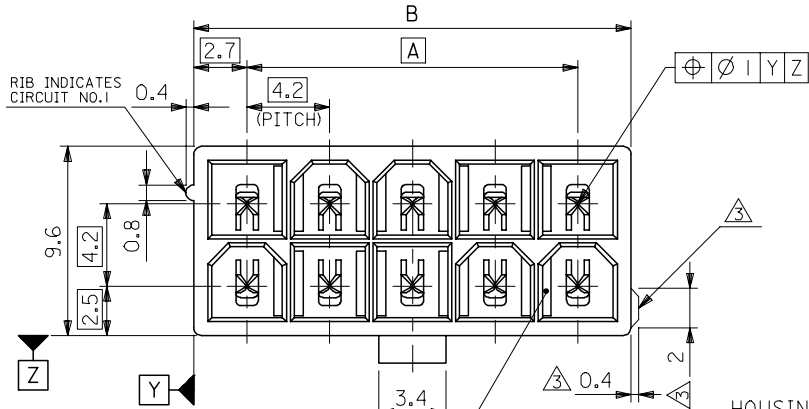

51.6	46.2	24
47.4	42	22
43.2	37.8	20
39	33.6	18
34.8	29.4	16
30.6	25.2	14
26.4	21	12
22.2	16.8	10
18	12.6	8
13.8	8.4	6
9.6	4.2	4
5.4	—	2
DIM. B	DIM. A	CKT. SIZE

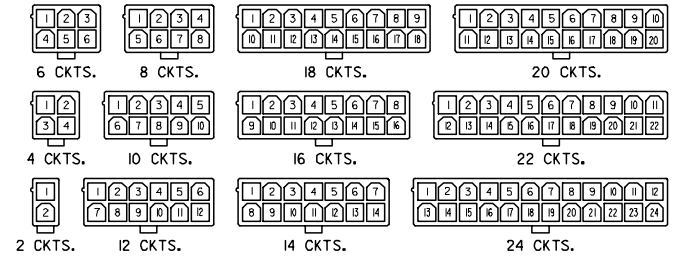

CIRCUIT SIZE LAYOUT
(SCALE 1:1)

DRAIN HOLES
(OPTION : SEE NOTE 2)

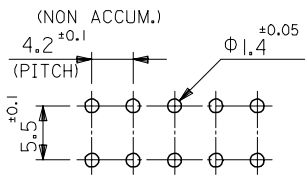
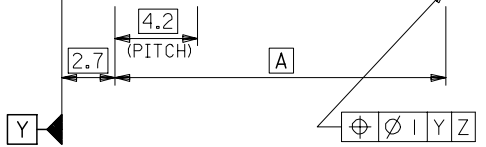
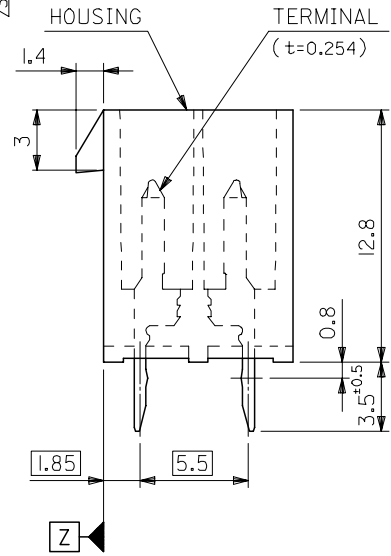
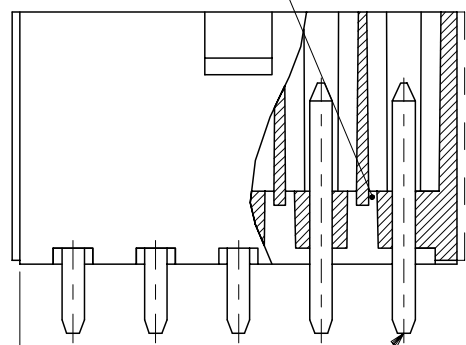

RECOMMENDED P.C. BOARD PATTERN
(SCALE 2:1)

NOTES

- MATE WITH : 5557 SERIES
- LEGEND
 BASE NUMBER _____
 CIRCUIT SIZE _____
 ASS'Y TYPE _____
 A : WITHOUT DRAIN HOLES
 B : WITH DRAIN HOLES
 TERMINAL MATERIAL _____
 "BLANK" : BRASS
 PB : PHOSPHOR BRONZE
 TERMINAL PLATING _____
 "BLANK" : BRIGHT TIN 0.9μm MIN. OVER COPPER 0.5μm MIN. (BRASS)
 TIN 0.9μm MIN. REFLOW TREATMENT
 OR BRIGHT TIN 0.9μm MIN. (PHOSPHOR BRONZE)
 S : BRIGHT TIN 2.54μm MIN. OVER NICKEL 1.27μm MIN.
 GS : SELECT GOLD 0.76μm MIN. AND SELECT PURE TIN 2.54μm MIN. OVER NICKEL 1.27μm MIN.
 GS2 : SELECT GOLD 0.38μm MIN. AND SELECT PURE TIN 2.54μm MIN. OVER NICKEL 1.27μm MIN.
 HOUSING MATERIAL _____
 "BLANK" : NYLON 66, UL94V-2
 210 : NYLON 66, UL94V-0
 310 : G.F. 30% PCT, UL94V-0
 400 : NYLON 66, UL94V-0, BLACK
 COLOR OR PACKAGING _____
 BL : BLACK RE : RED GR : GRAY
 BU : BLUE YE : YELLOW
 TA : TRAY PACKAGING FOR TRAYS (IN US)

EXTERNAL RIB APPEARS ON MX-USA PARTS ONLY. MODEL NO. 5566-N***-***

REVISED EC NO: J2007-2529 DRWNG: SAIT001 2007/03/07 CHKDK: TOYODA 2007/03/09 APPR: NUKITA 2007/03/12	GENERAL TOLERANCES (UNLESS SPECIFIED)		DIMENSION STYLE MM ONLY		SCALE 4:1	DESIGN UNITS METRIC	THIRD ANGLE PROJECTION
	10 UNDER	±0.2	DRAWN BY H. HIRAMOTO		TITLE NEW MINI FIT CONNECTOR HEADER HOUSING ASS'Y -LEAD FREE-		
	10 OVER 30 UNDER	±0.3	DATE '89/04/03		MOLEX INCORPORATED		
	30 OVER	±0.4	CHECKED BY M. FUKUSHIMA				
ANGULAR	±3 °	DATE '94/04/20		MATERIAL NO. SEE TABLE		DOCUMENT NO. SD-5566-002	SHEET NO. 1 OF 6
DRAFT WHERE APPLICABLE MUST REMAIN WITHIN DIMENSIONS		APPROVED BY M. FUKUSHIMA		DATE '94/04/20			

	10	9	8	7	6	5	4	3	2	1	
F	NOT TOOLED	5566-24APB-3IO	NOT TOOLED	5566-24AGS2-3IO	NOT TOOLED	5566-24AGS-3IO	NOT TOOLED	5566-24AS-3IO	NOT TOOLED	5566-24A-3IO	24
	↑	↑	↑	↑	↑	↑	↑	↑	↑	↑	22
		-22APB-3IO		-22AGS2-3IO		-22AGS-3IO		-22AS-3IO		-22A-3IO	20
		-20APB-3IO		-20AGS2-3IO		-20AGS-3IO		-20AS-3IO		-20A-3IO	18
		-18APB-3IO		-18AGS2-3IO		-18AGS-3IO		-18AS-3IO		-18A-3IO	16
		-16APB-3IO		-16AGS2-3IO		-16AGS-3IO		-16AS-3IO		-16A-3IO	14
		-14APB-3IO		-14AGS2-3IO		-14AGS-3IO		-14AS-3IO		-14A-3IO	12
		-12APB-3IO		-12AGS2-3IO		-12AGS-3IO		-12AS-3IO		-12A-3IO	10
		-10APB-3IO		-10AGS2-3IO		-10AGS-3IO		-10AS-3IO		-10A-3IO	8
		-08APB-3IO		-08AGS2-3IO		-08AGS-3IO		-08AS-3IO		-08A-3IO	6
	-06APB-3IO		-06AGS2-3IO		-06AGS-3IO		-06AS-3IO		-06A-3IO	4	
	-04APB-3IO		-04AGS2-3IO		-04AGS-3IO		-04AS-3IO		-04A-3IO	2	
E	NOT TOOLED	5566-02APB-3IO	NOT TOOLED	5566-02AGS2-3IO	NOT TOOLED	5566-02AGS-3IO	NOT TOOLED	5566-02AS-3IO	NOT TOOLED	5566-02A-3IO	24
	EDP NO.	ENG. NO.	EDP NO.	ENG. NO.	EDP NO.	ENG. NO.	EDP NO.	ENG. NO.	EDP NO.	ENG. NO.	CKT. SIZE
	5566-NAPB-3IO		5566-NAGS2-3IO		5566-NAGS-3IO		5566-NAS-3IO		5566-NA-3IO		
	39-29-5247	5566-24APB-2IO	39-30-9245	5566-24AGS2-2IO	39-29-6248	5566-24AGS-2IO	39-30-6242	5566-24AS-2IO	39-28-8240	5566-24A-2IO	24
	↑	↑	↑	↑	↑	↑	↑	↑	↑	↑	22
	-5207	-20APB-2IO	-9205	-20AGS2-2IO	-6208	-20AGS-2IO	-6202	-20AS-2IO	-8200	-20A-2IO	20
	-5187	-18APB-2IO	-9185	-18AGS2-2IO	-6188	-18AGS-2IO	-6182	-18AS-2IO	-8180	-18A-2IO	18
	-5167	-16APB-2IO	-9165	-16AGS2-2IO	-6168	-16AGS-2IO	-6162	-16AS-2IO	-8160	-16A-2IO	16
	-5147	-14APB-2IO	-9145	-14AGS2-2IO	-6148	-14AGS-2IO	-6142	-14AS-2IO	-8140	-14A-2IO	14
	-5127	-12APB-2IO	-9125	-12AGS2-2IO	-6128	-12AGS-2IO	-6122	-12AS-2IO	-8120	-12A-2IO	12
-5107	-10APB-2IO	-9105	-10AGS2-2IO	-6108	-10AGS-2IO	-6102	-10AS-2IO	-8100	-10A-2IO	10	
-5087	-08APB-2IO	-9085	-08AGS2-2IO	-6088	-08AGS-2IO	-6082	-08AS-2IO	-8080	-08A-2IO	8	
-5067	-06APB-2IO	-9065	-06AGS2-2IO	-6068	-06AGS-2IO	-6062	-06AS-2IO	-8060	-06A-2IO	6	
-5047	-04APB-2IO	-9045	-04AGS2-2IO	-6048	-04AGS-2IO	-6042	-04AS-2IO	-8040	-04A-2IO	4	
39-29-5027	5566-02APB-2IO	39-30-9025	5566-02AGS2-2IO	39-29-6028	5566-02AGS-2IO	39-30-6022	5566-02AS-2IO	39-28-8020	5566-02A-2IO	2	
EDP NO.	ENG. NO.	EDP NO.	ENG. NO.	EDP NO.	ENG. NO.	EDP NO.	ENG. NO.	EDP NO.	ENG. NO.	CKT. SIZE	
5566-NAPB-2IO		5566-NAGS2-2IO		5566-NAGS-2IO		5566-NAS-2IO		5566-NA-2IO			
39-29-5246	5566-24APB	39-30-9244	5566-24AGS2	39-29-0243	5566-24AGS	39-30-6241	5566-24AS	39-28-1243	5566-24A	24	
↑	↑	↑	↑	↑	↑	↑	↑	↑	↑	22	
-5206	-20APB	-9204	-20AGS2	-0203	-20AGS	-6201	-20AS	-1203	-20A	20	
-5186	-18APB	-9184	-18AGS2	-0183	-18AGS	-6181	-18AS	-1183	-18A	18	
-5166	-16APB	-9164	-16AGS2	-0163	-16AGS	-6161	-16AS	-1163	-16A	16	
-5146	-14APB	-9144	-14AGS2	-0143	-14AGS	-6141	-14AS	-1143	-14A	14	
-5126	-12APB	-9124	-12AGS2	-0123	-12AGS	-6121	-12AS	-1123	-12A	12	
-5106	-10APB	-9104	-10AGS2	-0103	-10AGS	-6101	-10AS	-1103	-10A	10	
-5086	-08APB	-9084	-08AGS2	-0083	-08AGS	-6081	-08AS	-1083	-08A	8	
-5066	-06APB	-9064	-06AGS2	-0063	-06AGS	-6061	-06AS	-1063	-06A	6	
-5046	-04APB	-9044	-04AGS2	-0043	-04AGS	-6041	-04AS	-1043	-04A	4	
39-29-5026	5566-02APB	39-30-9024	5566-02AGS2	39-29-0023	5566-02AGS	39-30-6021	5566-02AS	39-28-1023	5566-02A	2	
EDP NO.	ENG. NO.	EDP NO.	ENG. NO.	EDP NO.	ENG. NO.	EDP NO.	ENG. NO.	EDP NO.	ENG. NO.	CKT. SIZE	
5566-NAPB		5566-NAGS2		5566-NAGS		5566-NAS		5566-NA			

A	REVISED EC NO: J2007-2529 DRW:KSAI T001 2007/03/07 CHKD:KTOYODA 2007/03/09 APPR:NUKITA 2007/03/12	DESCRIPTION	GENERAL TOLERANCES (UNLESS SPECIFIED)		DIMENSION STYLE MM ONLY		SCALE ---	DESIGN UNITS METRIC	THIRD ANGLE PROJECTION	
			10 UNDER	± ---	DRAWN BY H. HIRAMOTO	DATE '89/04/03	TITLE NEW MINI FIT CONNECTOR HEADER HOUSING ASS'Y -LEAD FREE-			
			10 OVER 30 UNDER	± ---	CHECKED BY M. FUKUSHIMA	DATE '94/04/20	MOLEX INCORPORATED			
			30 OVER	± ---	APPROVED BY M. FUKUSHIMA	DATE '94/04/20	DOCUMENT NO. SD-5566-002			
			ANGULAR	± --- °	MATERIAL NO. SEE TABLE		SHEET NO. 2 OF 6			
		DRAFT WHERE APPLICABLE MUST REMAIN WITHIN DIMENSIONS		SIZE A3		THIS DRAWING CONTAINS INFORMATION THAT IS PROPRIETARY TO MOLEX INCORPORATED AND SHOULD NOT BE USED WITHOUT WRITTEN PERMISSION				

	10	9	8	7	6	5	4	3	2	1	
F	NOT TOOLED	5566-24BGS2-310	NOT TOOLED	5566-24BGS-310	NOT TOOLED	5566-24BS-310	NOT TOOLED	5566-24B-310	NOT TOOLED	5566-24APBS-310	24
	↑	↑ -22BGS2-310	↑	↑ -22BGS-310	↑	↑ -22BS-310	↑	↑ -22B-310	↑	↑ -22APBS-310	22
		↑ -20BGS2-310		↑ -20BGS-310		↑ -20BS-310		↑ -20B-310		↑ -20APBS-310	20
		↑ -18BGS2-310		↑ -18BGS-310		↑ -18BS-310		↑ -18B-310		↑ -18APBS-310	18
		↑ -16BGS2-310		↑ -16BGS-310		↑ -16BS-310		↑ -16B-310		↑ -16APBS-310	16
		↑ -14BGS2-310		↑ -14BGS-310		↑ -14BS-310		↑ -14B-310		↑ -14APBS-310	14
		↑ -12BGS2-310		↑ -12BGS-310		↑ -12BS-310		↑ -12B-310		↑ -12APBS-310	12
		↑ -10BGS2-310		↑ -10BGS-310		↑ -10BS-310		↑ -10B-310		↑ -10APBS-310	10
		↑ -08BGS2-310		↑ -08BGS-310		↑ -08BS-310		↑ -08B-310		↑ -08APBS-310	8
		↑ -06BGS2-310		↑ -06BGS-310		↑ -06BS-310		↑ -06B-310		↑ -06APBS-310	6
	↓ -04BGS2-310		↓ -04BGS-310		↓ -04BS-310		↓ -04B-310		↓ -04APBS-310	4	
E	NOT TOOLED	5566-02BGS2-310	NOT TOOLED	5566-02BGS-310	NOT TOOLED	5566-02BS-310	NOT TOOLED	5566-02B-310	NOT TOOLED	5566-02APBS-310	2
	EDP NO.	ENG. NO.	EDP NO.	ENG. NO.	EDP NO.	ENG. NO.	EDP NO.	ENG. NO.	EDP NO.	ENG. NO.	CKT. SIZE
		5566-NBGS2-310		5566-NBGS-310		5566-NBS-310		5566-NB-310		5566-NAPBS-310	
	39-30-9247	5566-24BGS2-210	39-31-0248	5566-24BGS-210	39-31-0242	5566-24BS-210	39-31-0240	5566-24B-210	39-30-6244	5566-24APBS-210	24
	↑ -9227	↑ -22BGS2-210	↑ -0228	↑ -22BGS-210	↑ -0222	↑ -22BS-210	↑ -0220	↑ -22B-210	↑ -6224	↑ -22APBS-210	22
	↑ -9207	↑ -20BGS2-210	↑ -0208	↑ -20BGS-210	↑ -0202	↑ -20BS-210	↑ -0200	↑ -20B-210	↑ -6204	↑ -20APBS-210	20
	↑ -9187	↑ -18BGS2-210	↑ -0188	↑ -18BGS-210	↑ -0182	↑ -18BS-210	↑ -0180	↑ -18B-210	↑ -6184	↑ -18APBS-210	18
	↑ -9167	↑ -16BGS2-210	↑ -0168	↑ -16BGS-210	↑ -0162	↑ -16BS-210	↑ -0160	↑ -16B-210	↑ -6164	↑ -16APBS-210	16
	↑ -9147	↑ -14BGS2-210	↑ -0148	↑ -14BGS-210	↑ -0142	↑ -14BS-210	↑ -0140	↑ -14B-210	↑ -6144	↑ -14APBS-210	14
	↑ -9127	↑ -12BGS2-210	↑ -0128	↑ -12BGS-210	↑ -0122	↑ -12BS-210	↑ -0120	↑ -12B-210	↑ -6124	↑ -12APBS-210	12
↑ -9107	↑ -10BGS2-210	↑ -0108	↑ -10BGS-210	↑ -0102	↑ -10BS-210	↑ -0100	↑ -10B-210	↑ -6104	↑ -10APBS-210	10	
↑ -9087	↑ -08BGS2-210	↑ -0088	↑ -08BGS-210	↑ -0082	↑ -08BS-210	↑ -0080	↑ -08B-210	↑ -6084	↑ -08APBS-210	8	
↑ -9067	↑ -06BGS2-210	↑ -0068	↑ -06BGS-210	↑ -0062	↑ -06BS-210	↑ -0060	↑ -06B-210	↑ -6064	↑ -06APBS-210	6	
↓ -9047	↓ -04BGS2-210	↓ -0048	↓ -04BGS-210	↓ -0042	↓ -04BS-210	↓ -0040	↓ -04B-210	↓ -6044	↓ -04APBS-210	4	
39-30-9027	5566-02BGS2-210	39-31-0028	5566-02BGS-210	39-31-0022	5566-02BS-210	39-31-0020	5566-02B-210	39-30-6024	5566-02APBS-210	2	
EDP NO.	ENG. NO.	EDP NO.	ENG. NO.	EDP NO.	ENG. NO.	EDP NO.	ENG. NO.	EDP NO.	ENG. NO.	CKT. SIZE	
	5566-NBGS2-210		5566-NBGS-210		5566-NBS-210		5566-NB-210		5566-NAPBS-210		
39-30-9246	5566-24BGS2	39-31-0247	5566-24BGS	39-31-0241	5566-24BS	39-29-3246	5566-24B	39-30-6243	5566-24APBS	24	
↑ -9226	↑ -22BGS2	↑ -0227	↑ -22BGS	↑ -0221	↑ -22BS	↑ -3226	↑ -22B	↑ -6223	↑ -22APBS	22	
↑ -9206	↑ -20BGS2	↑ -0207	↑ -20BGS	↑ -0201	↑ -20BS	↑ -3206	↑ -20B	↑ -6203	↑ -20APBS	20	
↑ -9186	↑ -18BGS2	↑ -0187	↑ -18BGS	↑ -0181	↑ -18BS	↑ -3186	↑ -18B	↑ -6183	↑ -18APBS	18	
↑ -9166	↑ -16BGS2	↑ -0164	↑ -16BGS	↑ -0161	↑ -16BS	↑ -3166	↑ -16B	↑ -6163	↑ -16APBS	16	
↑ -9146	↑ -14BGS2	↑ -0147	↑ -14BGS	↑ -0141	↑ -14BS	↑ -3146	↑ -14B	↑ -6143	↑ -14APBS	14	
↑ -9126	↑ -12BGS2	↑ -0127	↑ -12BGS	↑ -0121	↑ -12BS	↑ -3126	↑ -12B	↑ -6123	↑ -12APBS	12	
↑ -9106	↑ -10BGS2	↑ -0107	↑ -10BGS	↑ -0101	↑ -10BS	↑ -3106	↑ -10B	↑ -6103	↑ -10APBS	10	
↑ -9086	↑ -08BGS2	↑ -0087	↑ -08BGS	↑ -0081	↑ -08BS	↑ -3086	↑ -08B	↑ -6083	↑ -08APBS	8	
↑ -9066	↑ -06BGS2	↑ -0067	↑ -06BGS	↑ -0061	↑ -06BS	↑ -3066	↑ -06B	↑ -6063	↑ -06APBS	6	
↓ -9046	↓ -04BGS2	↓ -0047	↓ -04BGS	↓ -0041	↓ -04BS	↓ -3046	↓ -04B	↓ -6043	↓ -04APBS	4	
39-30-9026	5566-02BGS2	39-31-0027	5566-02BGS	39-31-0021	5566-02BS	39-29-3026	5566-02B	39-30-6023	5566-02APBS	2	
EDP NO.	ENG. NO.	EDP NO.	ENG. NO.	EDP NO.	ENG. NO.	EDP NO.	ENG. NO.	EDP NO.	ENG. NO.	CKT. SIZE	
	5566-NBGS2		5566-NBGS		5566-NBS		5566-NB		5566-NAPBS		

REVISED EC NO: J2007-2529 DRW:KSAI T001 2007/03/07 CHK:KATOY00A 2007/03/09 APPR:NUKITA 2007/03/12 REV	GENERAL TOLERANCES (UNLESS SPECIFIED)		DIMENSION STYLE MM ONLY		SCALE ---	DESIGN UNITS METRIC	THIRD ANGLE PROJECTION	
	10 UNDER	± ---	DRAWN BY H. HIRAMOTO	DATE '89/04/03	TITLE NEW MINI FIT CONNECTOR HEADER HOUSING ASS'Y -LEAD FREE-			
	10 OVER 30 UNDER	± ---	CHECKED BY M. FUKUSHIMA	DATE '94/04/20	MOLEX INCORPORATED			
	30 OVER	± ---	APPROVED BY M. FUKUSHIMA	DATE '94/04/20	DOCUMENT NO. SD-5566-002		SHEET NO. 3 OF 6	
	ANGULAR ± --- °		MATERIAL NO. SEE TABLE					
DRAFT WHERE APPLICABLE MUST REMAIN WITHIN DIMENSIONS		SIZE A3		THIS DRAWING CONTAINS INFORMATION THAT IS PROPRIETARY TO MOLEX INCORPORATED AND SHOULD NOT BE USED WITHOUT WRITTEN PERMISSION				

10 9 8 7 6 5 4 3 2 1

F

F

E

E

D

D

C

C

B

B

A

A

									24	
									22	
									20	
									18	
					39-33-3169	5566-16A-210-BU	39-33-3168	5566-16A-210-BL	16	
									14	
									12	
			39-33-4100	5566-10A-210-RE	39-33-3109	5566-10A-210-BU	39-33-3108	5566-10A-210-BL	10	
							39-33-3088	5566-08A-210-BL	8	
									6	
			39-33-4040	5566-04A-210-RE	39-33-3049	5566-04A-210-BU			4	
39-34-5023	5566-02A-210-YE	39-33-4020	5566-02A-210-RE	39-33-3029	5566-02A-210-BU	39-33-3028	5566-02A-210-BL		2	
EDP. NO.	ENG. NO.	EDP. NO.	ENG. NO.	EDP. NO.	ENG. NO.	EDP. NO.	ENG. NO.		CKT. SIZE	
5566-NA-210-YE		5566-NA-210-RE		5566-NA-210-BU		5566-NA-210-BL				
									24	
									22	
									20	
									18	
			39-33-3166	5566-16A-RE	39-33-3164	5566-16A-BU			16	
39-33-3145	5566-14A-GR						39-33-3143	5566-14A-BL	14	
			39-33-3126	5566-12A-RE	39-33-3124	5566-12A-BU			12	
			39-33-3106	5566-10A-RE	39-33-3104	5566-10A-BU			10	
		39-33-3087	5566-08A-YE	39-33-3086	5566-08A-RE	39-33-3084	5566-08A-BU	39-33-3083	5566-08A-BL	8
		39-33-3067	5566-06A-YE	39-33-3066	5566-06A-RE	39-33-3064	5566-06A-BU	39-33-3063	5566-06A-BL	6
			39-33-3046	5566-04A-RE	39-33-3044	5566-04A-BU	39-33-3043	5566-04A-BL	4	
		39-33-3027	5566-02A-YE	39-33-3026	5566-02A-RE	39-33-3024	5566-02A-BU	39-33-3023	5566-02A-BL	2
EDP. NO.	ENG. NO.	EDP. NO.	ENG. NO.	EDP. NO.	ENG. NO.	EDP. NO.	ENG. NO.	EDP. NO.	ENG. NO.	CKT. SIZE
5566-NA-GR		5566-NA-YE		5566-NA-RE		5566-NA-BU		5566-NA-BL		

REVISED EC NO: J2007-2529 DRW:KSAIT001 2007/03/07 CHK:KTOY00A 2007/03/09 APPR:NUKITA 2007/03/12	GENERAL TOLERANCES (UNLESS SPECIFIED)		DIMENSION STYLE MM ONLY		SCALE ---	DESIGN UNITS METRIC	THIRD ANGLE PROJECTION	
	10 UNDER	± ---	DRAWN BY H.HIRAMOTO	DATE '89/04/03	TITLE NEW MINI FIT CONNECTOR HEADER HOUSING ASS'Y -LEAD FREE-			
	10 ^{OVER} 30 UNDER	± ---	CHECKED BY M.FUKUSHIMA	DATE '94/04/20	MOLEX INCORPORATED			
	30 ^{OVER}	± ---	APPROVED BY M.FUKUSHIMA	DATE '94/04/20	DOCUMENT NO. SD-5566-002			
	ANGULAR ± --- °		MATERIAL NO. SEE TABLE		SHEET NO. 5 OF 6			
DRAFT WHERE APPLICABLE MUST REMAIN WITHIN DIMENSIONS		SIZE A3		THIS DRAWING CONTAINS INFORMATION THAT IS PROPRIETARY TO MOLEX INCORPORATED AND SHOULD NOT BE USED WITHOUT WRITTEN PERMISSION				

F

E

D

C

B

A

39-54-0245	5566-24BGS-210-TA	39-54-0244	5566-24B-210-TA	39-54-0243	5566-24BGS-TA	39-54-0242	5566-24B-TA	24
▲ -0225	▲ -22BGS-210-TA	▲ -0224	▲ -22B-210-TA	▲ -0223	▲ -22BGS-TA	▲ -0222	▲ -22B-TA	22
-0205	-20BGS-210-TA	-0204	-20B-210-TA	-0203	-20BGS-TA	-0202	-20B-TA	20
-0185	-18BGS-210-TA	-0184	-18B-210-TA	-0183	-18BGS-TA	-0182	-18B-TA	18
-0165	-16BGS-210-TA	-0164	-16B-210-TA	-0163	-16BGS-TA	-0162	-16B-TA	16
-0145	-14BGS-210-TA	-0144	-14B-210-TA	-0143	-14BGS-TA	-0142	-14B-TA	14
-0125	-12BGS-210-TA	-0124	-12B-210-TA	-0123	-12BGS-TA	-0122	-12B-TA	12
-0105	-10BGS-210-TA	-0104	-10B-210-TA	-0103	-10BGS-TA	-0102	-10B-TA	10
-0085	-08BGS-210-TA	-0084	-08B-210-TA	-0083	-08BGS-TA	-0082	-08B-TA	8
-0065	-06BGS-210-TA	-0064	-06B-210-TA	-0063	-06BGS-TA	-0062	-06B-TA	6
▼ -0045	▼ -04BGS-210-TA	▼ -0044	▼ -04B-210-TA	▼ -0043	▼ -04BGS-TA	▼ -0042	▼ -04B-TA	4
39-54-0025	5566-02BGS-210-TA	39-54-0024	5566-02B-210-TA	39-54-0023	5566-02BGS-TA	39-54-0022	5566-02B-TA	2
EDP NO.	ENG. NO.	EDP NO.	ENG. NO.	EDP NO.	ENG. NO.	EDP NO.	ENG. NO.	CKT. SIZE
5566-NBGS-210-TA		5566-NB-210-TA		5566-NBGS-TA		5566-NB-TA		

39-54-0241	5566-24AGS-210-TA	39-54-0240	5566-24AGS-TA	39-53-9249	5566-24A-210-TA	39-53-9248	5566-24A-TA	24
▲ -0221	▲ -22AGS-210-TA	▲ -0220	▲ -22AGS-TA	▲ -9229	▲ -22A-210-TA	▲ -9228	▲ -22A-TA	22
-0201	-20AGS-210-TA	-0200	-20AGS-TA	-9209	-20A-210-TA	-9208	-20A-TA	20
-0181	-18AGS-210-TA	-0180	-18AGS-TA	-9189	-18A-210-TA	-9188	-18A-TA	18
-0161	-16AGS-210-TA	-0160	-16AGS-TA	-9169	-16A-210-TA	-9168	-16A-TA	16
-0141	-14AGS-210-TA	-0140	-14AGS-TA	-9149	-14A-210-TA	-9148	-14A-TA	14
-0121	-12AGS-210-TA	-0120	-12AGS-TA	-9129	-12A-210-TA	-9128	-12A-TA	12
-0101	-10AGS-210-TA	-0100	-10AGS-TA	-9109	-10A-210-TA	-9108	-10A-TA	10
-0081	-08AGS-210-TA	-0080	-08AGS-TA	-9089	-08A-210-TA	-9088	-08A-TA	8
-0061	-06AGS-210-TA	-0060	-06AGS-TA	-9069	-06A-210-TA	-9068	-06A-TA	6
▼ -0041	▼ -04AGS-210-TA	▼ -0040	▼ -04AGS-TA	▼ -9049	▼ -04A-210-TA	▼ -9048	▼ -04A-TA	4
39-54-0021	5566-02AGS-210-TA	39-54-0020	5566-02AGS-TA	39-53-9029	5566-02A-210-TA	39-53-9028	5566-02A-TA	2
EDP NO.	ENG. NO.	EDP NO.	ENG. NO.	EDP NO.	ENG. NO.	EDP NO.	ENG. NO.	CKT. SIZE
5566-NAGS-210-TA		5566-NAGS-TA		5566-NA-210-TA		5566-NA-TA		

REVISED EC NO: J2007-2529 DRWNG SAI T001 2007/03/07 CHKDK: TOYODA 2007/03/09 APPR: NUKITA 2007/03/12	GENERAL TOLERANCES (UNLESS SPECIFIED)		DIMENSION STYLE MM ONLY		SCALE ---	DESIGN UNITS METRIC	THIRD ANGLE PROJECTION	
	10 UNDER	± ---	DRAWN BY DATE H. HIRAMOTO '89/04/03		TITLE NEW MINI FIT CONNECTOR HEADER HOUSING ASS'Y -LEAD FREE-			
	10 OVER 30 UNDER	± ---	CHECKED BY DATE M. FUKUSHIMA '94/04/20		MOLEX INCORPORATED			
	30 OVER	± ---	APPROVED BY DATE M. FUKUSHIMA '94/04/20		DOCUMENT NO. SD-5566-002		SHEET NO. 6 OF 6	
ANGULAR ± --- °		DRAFT WHERE APPLICABLE MUST REMAIN WITHIN DIMENSIONS		MATERIAL NO. SEE TABLE				
5566-N*****		MODEL NO. L		SIZE A3		THIS DRAWING CONTAINS INFORMATION THAT IS PROPRIETARY TO MOLEX INCORPORATED AND SHOULD NOT BE USED WITHOUT WRITTEN PERMISSION		

10 9 8 7 6 5 4 3 2 1

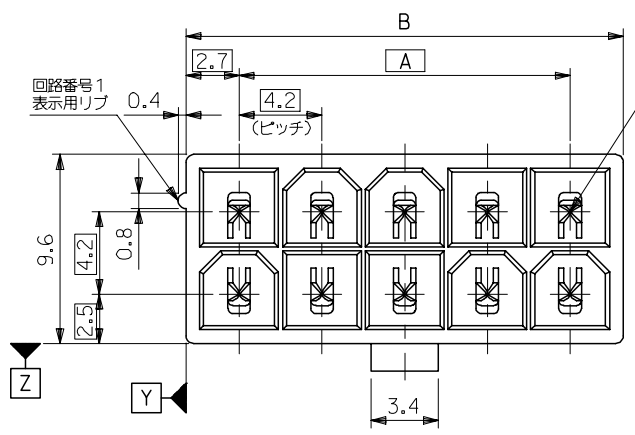

51.6	46.2	24
47.4	42	22
43.2	37.8	20
39	33.6	18
34.8	29.4	16
30.6	25.2	14
26.4	21	12
22.2	16.8	10
18	12.6	8
13.8	8.4	6
9.6	4.2	4
5.4	—	2
寸法 B	寸法 A	極数

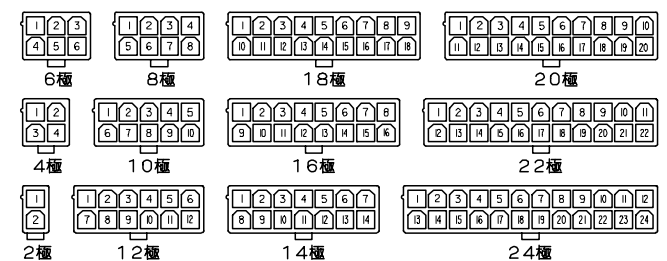

極数別レイアウト図
(SCALE 1:1)

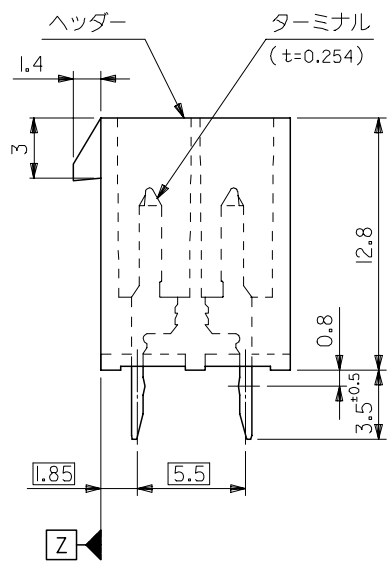
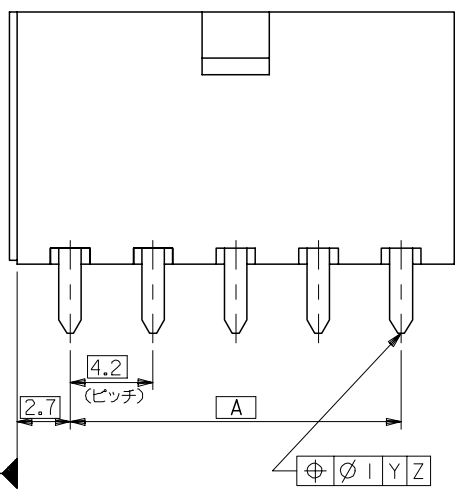

注記

1. 嵌合相手：5557シリーズ
 2. 使用符号の説明
- 5566 - N A * * - * - *
- ベースナンバー _____
- 極数 _____
- アッセンブリー _____
- ターミナル材料 _____
- "BLANK": 黄銅
PB: リン青銅
- ターミナルのメッキ _____
- "BLANK": 錫メッキ 0.9μm MIN.
GS: ニッケル 1.27μm MIN. 全面下地
コンタクト部 金 0.76μm MIN.
半田付け部 錫 2.54μm MIN.
- ヘッダー材料 _____
- "BLANK": ナイロン 66, UL 94V-2
210: ナイロン 66, UL 94V-0
400: ナイロン 66, UL 94V-0, 黒
- 色
- BL: 黒色
BU: 青色
RE: 赤色
YE: 黄色
GR: 灰色

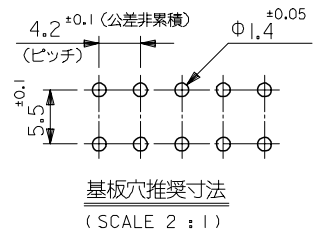

基板穴推奨寸法
(SCALE 2:1)

REVISED EC NO: J2006-2418 DRW: NABEI 2006/01/30 CHK: KYOYODA 2006/02/03 APP: NUKITA 2006/02/06	GENERAL TOLERANCES (UNLESS SPECIFIED)		DIMENSION STYLE MM ONLY	SCALE 4:1	DESIGN UNITS METRIC	THIRD ANGLE PROJECTION
	10 UNDER	±0.2	DRAWN BY H. HIRAMOTO	DATE '89/05/07	TITLE NEW MINI FIT CONNECTOR HEADER ASS'Y -LEAD FREE-	
	10 OVER 30 UNDER	±0.3	CHECKED BY M. FUKUSHIMA	DATE '91/10/29	MOLEX INCORPORATED	
	30 OVER	±0.4	APPROVED BY M. ENOMOTO	DATE '91/10/29	DOCUMENT NO. SD-5566-003	SHEET NO. 1 OF 3
	ANGULAR	±3 °	MATERIAL NO. SEE CHART	THIS DRAWING CONTAINS INFORMATION THAT IS PROPRIETARY TO MOLEX INCORPORATED AND SHOULD NOT BE USED WITHOUT WRITTEN PERMISSION		
	DRAFT WHERE APPLICABLE MUST REMAIN WITHIN DIMENSIONS		SIZE A3			

10 9 8 7 6 5 4 3 2 1

F

E

D

C

B

A

39-35-0248	5566-24A-400	24
▲ -0228	▲ -22A-400	22
-0208	-20A-400	20
-0188	-18A-400	18
-0168	-16A-400	16
-0148	-14A-400	14
-0128	-12A-400	12
-0108	-10A-400	10
-0088	-08A-400	8
-0068	-06A-400	6
▼ -0048	▼ -04A-400	4
39-35-0028	5566-02A-400	2
EDP NO.	ENG. NO.	極数
5566-NA-400		

39-29-5247	5566-24APB-210	39-29-6248	5566-24AGS-210	39-28-8240	5566-24A-210	24
▲ -5227	▲ -22APB-210	▲ -6228	▲ -22AGS-210	▲ -8220	▲ -22A-210	22
-5207	-20APB-210	-6208	-20AGS-210	-8200	-20A-210	20
-5187	-18APB-210	-6188	-18AGS-210	-8180	-18A-210	18
-5167	-16APB-210	-6168	-16AGS-210	-8160	-16A-210	16
-5147	-14APB-210	-6148	-14AGS-210	-8140	-14A-210	14
-5127	-12APB-210	-6128	-12AGS-210	-8120	-12A-210	12
-5107	-10APB-210	-6108	-10AGS-210	-8100	-10A-210	10
-5087	-08APB-210	-6088	-08AGS-210	-8080	-08A-210	8
-5067	-06APB-210	-6068	-06AGS-210	-8060	-06A-210	6
▼ -5047	▼ -04APB-210	▼ -6048	▼ -04AGS-210	▼ -8040	▼ -04A-210	4
39-29-5027	5566-02APB-210	39-29-6028	5566-02AGS-210	39-28-8020	5566-02A-210	2
EDP NO.	ENG. NO.	EDP NO.	ENG. NO.	EDP NO.	ENG. NO.	極数
5566-NAPB-210		5566-NAGS-210		5566-NA-210		
39-29-5246	5566-24APB	39-29-0243	5566-24AGS	39-28-1243	5566-24A	24
▲ -5226	▲ -22APB	▲ -0223	▲ -22AGS	▲ -1223	▲ -22A	22
-5206	-20APB	-0203	-20AGS	-1203	-20A	20
-5186	-18APB	-0183	-18AGS	-1183	-18A	18
-5166	-16APB	-0163	-16AGS	-1163	-16A	16
-5146	-14APB	-0143	-14AGS	-1143	-14A	14
-5126	-12APB	-0123	-12AGS	-1123	-12A	12
-5106	-10APB	-0103	-10AGS	-1103	-10A	10
-5086	-08APB	-0083	-08AGS	-1083	-08A	8
-5066	-06APB	-0063	-06AGS	-1063	-06A	6
▼ -5046	▼ -04APB	▼ -0043	▼ -04AGS	▼ -1043	▼ -04A	4
39-29-5026	5566-02APB	39-29-0023	5566-02AGS	39-28-1023	5566-02A	2
EDP NO.	ENG. NO.	EDP NO.	ENG. NO.	EDP NO.	ENG. NO.	極数
5566-NAPB		5566-NAGS		5566-NA		

REVISED EC NO: J2006-2418 DRWN: NABEI 2006/01/30 CHKD: KTOYODA 2006/02/03 APPR: NUKITA 2006/02/06	GENERAL TOLERANCES (UNLESS SPECIFIED)		DIMENSION STYLE MM ONLY		SCALE ---	DESIGN UNITS METRIC	THIRD ANGLE PROJECTION		
	10 UNDER	± ---	DRAWN BY H.HIRAMOTO	DATE '89/05/07	TITLE NEW MINI FIT CONNECTOR HEADER ASS'Y -LEAD FREE-				
	10 OVER 30 UNDER	± ---	CHECKED BY M.FUKUSHIMA	DATE '91/10/29					
	30 OVER	± ---	APPROVED BY M.ENOMOTO	DATE '91/10/29	MOLEX INCORPORATED				
ANGULAR	± --- °	MATERIAL NO. SEE CHART		DOCUMENT NO. SD-5566-003					SHEET NO. 2 OF 3
DRAFT WHERE APPLICABLE MUST REMAIN WITHIN DIMENSIONS		SIZE A3	THIS DRAWING CONTAINS INFORMATION THAT IS PROPRIETARY TO MOLEX INCORPORATED AND SHOULD NOT BE USED WITHOUT WRITTEN PERMISSION						

F

E

D

C

B

A

									24
									22
									20
									18
					39-33-3169	5566-16A-210-BU	39-33-3168	5566-16A-210-BL	16
									14
									12
			39-33-4100	5566-10A-210-RE	39-33-3109	5566-10A-210-BU	39-33-3108	5566-10A-210-BL	10
							39-33-3088	5566-08A-210-BL	8
									6
			39-33-4040	5566-04A-210-RE	39-33-3049	5566-04A-210-BU			4
39-34-5023	5566-02A-210-YE	39-33-4020	5566-02A-210-RE	39-33-3029	5566-02A-210-BU	39-33-3028	5566-02A-210-BL		2
EDP. NO.	ENG. NO.	EDP. NO.	ENG. NO.	EDP. NO.	ENG. NO.	EDP. NO.	ENG. NO.		極数
5566-NA-210-YE		5566-NA-210-RE		5566-NA-210-BU		5566-NA-210-BL			
									24
									22
									20
									18
39-33-3145	5566-14A-GR			39-33-3166	5566-16A-RE	39-33-3164	5566-16A-BU		16
				39-33-3126	5566-12A-RE	39-33-3124	5566-12A-BU	39-33-3143	5566-14A-BL
				39-33-3106	5566-10A-RE	39-33-3104	5566-10A-BU		14
		39-33-3087	5566-08A-YE	39-33-3086	5566-08A-RE	39-33-3084	5566-08A-BU		12
		39-33-3067	5566-06A-YE	39-33-3066	5566-06A-RE	39-33-3064	5566-06A-BU		10
				39-33-3046	5566-04A-RE	39-33-3044	5566-04A-BU	39-33-3043	5566-04A-BL
		39-33-3027	5566-02A-YE	39-33-3026	5566-02A-RE	39-33-3024	5566-02A-BU	39-33-3023	5566-02A-BL
EDP. NO.	ENG. NO.	EDP. NO.	ENG. NO.	EDP. NO.	ENG. NO.	EDP. NO.	ENG. NO.	EDP. NO.	ENG. NO.
5566-NA-GR		5566-NA-YE		5566-NA-RE		5566-NA-BU		5566-NA-BL	
									極数

REVISED EC NO: J2006-2418 DRWN: NABEI 2006/01/30 CHKDK: TOYODA 2006/02/03 APPR: NUKITA 2006/02/06	GENERAL TOLERANCES (UNLESS SPECIFIED)		DIMENSION STYLE MM ONLY		SCALE ---	DESIGN UNITS METRIC	THIRD ANGLE PROJECTION	
	10 UNDER	± ---	DRAWN BY H. HIRAMOTO	DATE '89/05/07	TITLE NEW MINI FIT CONNECTOR HEADER ASS'Y -LEAD FREE-			
	10 OVER 30 UNDER	± ---	CHECKED BY M. FUKUSHIMA	DATE '91/10/29				
	30 OVER	± ---	APPROVED BY M. ENOMOTO	DATE '91/10/29	MOLEX INCORPORATED DOCUMENT NO. SD-5566-003 SHEET NO. 3 OF 3			
	ANGULAR	± --- °	MATERIAL NO.					
DRAFT WHERE APPLICABLE MUST REMAIN WITHIN DIMENSIONS		SEE CHART		THIS DRAWING CONTAINS INFORMATION THAT IS PROPRIETARY TO MOLEX INCORPORATED AND SHOULD NOT BE USED WITHOUT WRITTEN PERMISSION				

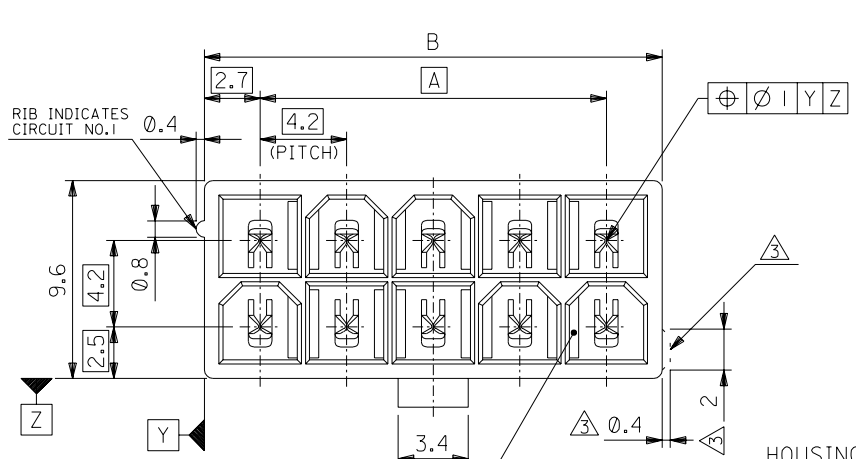

51.6	46.2	24
47.4	42	22
43.2	37.8	20
39	33.6	18
34.8	29.4	16
30.6	25.2	14
26.4	21	12
22.2	16.8	10
18	12.6	8
13.8	8.4	6
9.6	4.2	4
5.4	—	2
DIM. B	DIM. A	CKT. SIZE

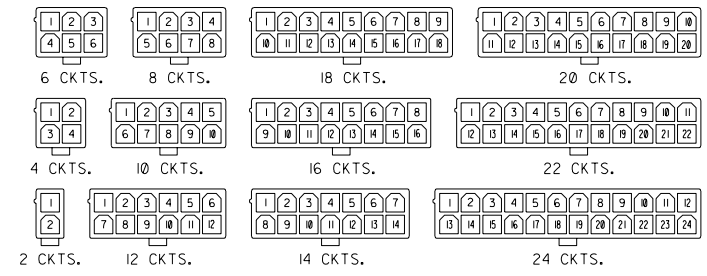

CIRCUIT SIZE LAYOUT (SCALE 1:1)

DRAIN HOLES (OPTION : SEE NOTE 2)

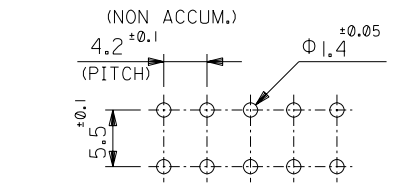
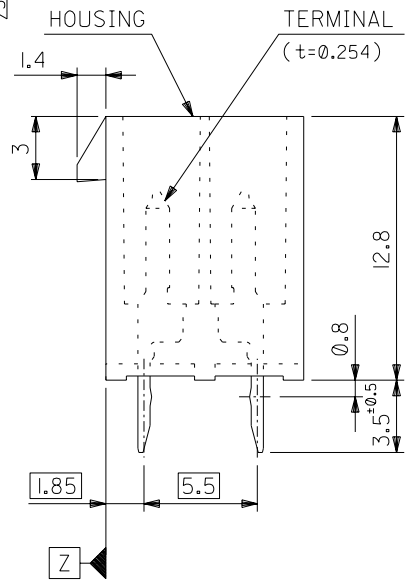
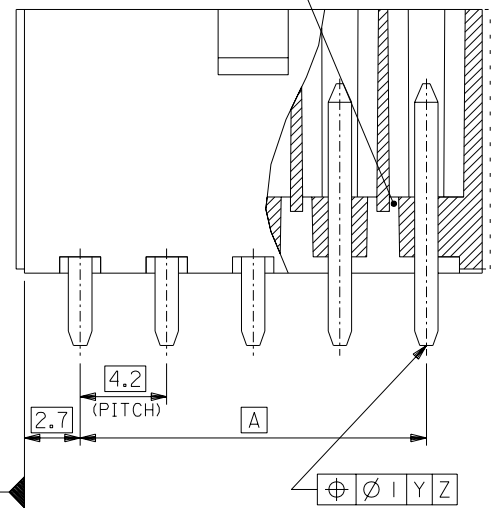

RECOMMENDED P.C. BOARD PATTERN (SCALE 2:1)

NOTES

- MATE WITH : 5557 SERIES
 - LEGEND
 - BASE NUMBER 5566 - N * * * - *
 - CIRCUIT SIZE _____
 - ASS'Y TYPE _____
 - A : WITHOUT DRAIN HOLES
 - B : WITH DRAIN HOLES
 - TERMINAL MATERIAL _____
 - "BLANK" : BRASS
 - PB : PHOSPHOR BRONZE
 - TERMINAL PLATING _____
 - "BLANK" : BRIGHT TIN 0.9μm MIN. OVER COPPER 0.5μm MIN. (BRASS)
 - TIN 0.9μm MIN. REFLOW TREATMENT
 - OR BRIGHT TIN 0.9μm MIN. (PHOSPHOR BRONZE)
 - S : BRIGHT TIN 2.54μm MIN. OVER NICKEL 1.27μm MIN.
 - GS : SELECT GOLD 0.76μm MIN. AND SELECT PURE TIN 2.54μm MIN. OVER NICKEL 1.27μm MIN.
 - GS2 : SELECT GOLD 0.38μm MIN. AND SELECT PURE TIN 2.54μm MIN. OVER NICKEL 1.27μm MIN.
 - HOUSING MATERIAL _____
 - "BLANK" : NYLON 66, UL94V-2
 - 210 : NYLON 66, UL94V-0
 - 310 : G.F. 30% PCT, UL94V-0
 - 400 : NYLON 66, UL94V-0, BLACK
- △ EXTERNAL RIB APPEARS ON MX-USA PARTS ONLY.

5566-N****		J	REVISED (J2004-4416)	M.N. K.T	04/5/25	材料 MATERIAL	SEE NOTE 2	molex MOLEX-JAPAN CO.,LTD. 日本モレックス株式会社
MODEL NO.		H	REVISED (J40308)	H.H. M.F	94/4/19	仕上げ FINISH	SEE NOTE 2	
角度 ANGLE	±3°	G	REVISED (J10190)	H.H. Y.Y	91/3/7	適用電線範囲 WIRE RANGE	—	TITLE 名称
30°以上 OVER	±0.4	F	REVISED (J00638)	H.H. Y.Y	90/6/8	被覆外径 INS. RANGE	—	NEW MINI FIT CONNECTOR
10°以上 OVER 30°未滿 UNDER	±0.3 ±0.25	E	REVISED (J90681)	H.H. Y.Y	89/8/25			HEADER HOUSING ASS'Y
未滿 10° UNDER	±0.2	D	REVISED & REDRAWN (J90237)	H.H. Y.Y	89/4/3	DRAWN BY '89/4/3 H.HIRAMOTO	CHK'D BY '94/4/20 M.FUKUSHIMA	-LEAD FREE-
一般公差 GENERAL TOLERANCES	記号 LTR		変更内容 REVISION RECORD	DR. CHK.	日付 DATE	尺度 SCALE	4 : 1	DWG. NO. SHEET 1 OF 4 REV
								SD-5566-N****-*

DWG. NO. SD-5566-N****-*	8		7		6		5		4		3		2		1		
	NOT TOOLED	5566-24APB-310	NOT TOOLED	5566-24AGS2-310	NOT TOOLED	5566-24AGS2-310	NOT TOOLED	5566-24AGS-310	NOT TOOLED	5566-24AS-310	NOT TOOLED	5566-24AS-310	NOT TOOLED	5566-24A-310	24		
	↑	↑	↑	↑	↑	↑	↑	↑	↑	↑	↑	↑	↑	↑	22		
		-22APB-310		-22AGS2-310		-22AGS-310		-22AGS-310		-22AS-310		-22AS-310		-22A-310	20		
		-20APB-310		-20AGS2-310		-20AGS-310		-20AGS-310		-20AS-310		-20AS-310		-20A-310	18		
		-18APB-310		-18AGS2-310		-18AGS-310		-18AGS-310		-18AS-310		-18AS-310		-18A-310	16		
		-16APB-310		-16AGS2-310		-16AGS-310		-16AGS-310		-16AS-310		-16AS-310		-16A-310	14		
		-14APB-310		-14AGS2-310		-14AGS-310		-14AGS-310		-14AS-310		-14AS-310		-14A-310	12		
		-12APB-310		-12AGS2-310		-12AGS-310		-12AGS-310		-12AS-310		-12AS-310		-12A-310	10		
		-10APB-310		-10AGS2-310		-10AGS-310		-10AGS-310		-10AS-310		-10AS-310		-10A-310	8		
	-08APB-310		-08AGS2-310		-08AGS-310		-08AGS-310		-08AS-310		-08AS-310		-08A-310	6			
	-06APB-310		-06AGS2-310		-06AGS-310		-06AGS-310		-06AS-310		-06AS-310		-06A-310	4			
	-04APB-310		-04AGS2-310		-04AGS-310		-04AGS-310		-04AS-310		-04AS-310		-04A-310	2			
E	NOT TOOLED	5566-02APB-310	NOT TOOLED	5566-02AGS2-310	NOT TOOLED	5566-02AGS-310	NOT TOOLED	5566-02AS-310	NOT TOOLED	5566-02A-310	2						
	EDP NO.	ENG. NO.	EDP NO.	ENG. NO.	EDP NO.	ENG. NO.	EDP NO.	ENG. NO.	EDP NO.	ENG. NO.	CKT. SIZE						
	5566-NAPB-310		5566-NAGS2-310		5566-NAGS-310		5566-NAS-310		5566-NA-310								
	39-29-5247	5566-24APB-210	39-30-9245	5566-24AGS2-210	39-29-6248	5566-24AGS-210	39-30-6242	5566-24AS-210	39-28-8240	5566-24A-210	24						
	↑	↑	↑	↑	↑	↑	↑	↑	↑	↑	22						
		-5227		-22AGS2-210		-22AGS-210		-22AGS-210		-22AS-210		-22AS-210		-22A-210	20		
		-5207		-20AGS2-210		-20AGS-210		-20AGS-210		-20AS-210		-20AS-210		-20A-210	18		
		-5187		-18AGS2-210		-18AGS-210		-18AGS-210		-18AS-210		-18AS-210		-18A-210	16		
		-5167		-16AGS2-210		-16AGS-210		-16AGS-210		-16AS-210		-16AS-210		-16A-210	14		
		-5147		-14AGS2-210		-14AGS-210		-14AGS-210		-14AS-210		-14AS-210		-14A-210	12		
	-5127		-12AGS2-210		-12AGS-210		-12AGS-210		-12AS-210		-12AS-210		-12A-210	10			
	-5107		-10AGS2-210		-10AGS-210		-10AGS-210		-10AS-210		-10AS-210		-10A-210	8			
	-5087		-08AGS2-210		-08AGS-210		-08AGS-210		-08AS-210		-08AS-210		-08A-210	6			
	-5067		-06AGS2-210		-06AGS-210		-06AGS-210		-06AS-210		-06AS-210		-06A-210	4			
	-5047		-04AGS2-210		-04AGS-210		-04AGS-210		-04AS-210		-04AS-210		-04A-210	2			
D	39-29-5027	5566-02APB-210	39-30-9025	5566-02AGS2-210	39-29-6028	5566-02AGS-210	39-30-6022	5566-02AS-210	39-28-8020	5566-02A-210	2						
	EDP NO.	ENG. NO.	EDP NO.	ENG. NO.	EDP NO.	ENG. NO.	EDP NO.	ENG. NO.	EDP NO.	ENG. NO.	CKT. SIZE						
	5566-NAPB-210		5566-NAGS2-210		5566-NAGS-210		5566-NAS-210		5566-NA-210								
	39-29-5246	5566-24APB	39-30-9244	5566-24AGS2	39-29-0243	5566-24AGS	39-30-6241	5566-24AS	39-28-1243	5566-24A	24						
	↑	↑	↑	↑	↑	↑	↑	↑	↑	↑	22						
		-5226		-22AGS2		-22AGS		-22AGS		-22AS		-22AS		-22A	20		
		-5206		-20AGS2		-20AGS		-20AGS		-20AS		-20AS		-20A	18		
		-5186		-18AGS2		-18AGS		-18AGS		-18AS		-18AS		-18A	16		
		-5166		-16AGS2		-16AGS		-16AGS		-16AS		-16AS		-16A	14		
		-5146		-14AGS2		-14AGS		-14AGS		-14AS		-14AS		-14A	12		
	-5126		-12AGS2		-12AGS		-12AGS		-12AS		-12AS		-12A	10			
	-5106		-10AGS2		-10AGS		-10AGS		-10AS		-10AS		-10A	8			
	-5086		-08AGS2		-08AGS		-08AGS		-08AS		-08AS		-08A	6			
	-5066		-06AGS2		-06AGS		-06AGS		-06AS		-06AS		-06A	4			
	-5046		-04AGS2		-04AGS		-04AGS		-04AS		-04AS		-04A	2			
C	39-29-5026	5566-02APB	39-30-9024	5566-02AGS2	39-29-0023	5566-02AGS	39-30-6021	5566-02AS	39-28-1023	5566-02A	2						
	EDP NO.	ENG. NO.	EDP NO.	ENG. NO.	EDP NO.	ENG. NO.	EDP NO.	ENG. NO.	EDP NO.	ENG. NO.	CKT. SIZE						
	5566-NAPB		5566-NAGS2		5566-NAGS		5566-NAS		5566-NA								
B																	
A																	

5566-N****		J	SEE SHEET 1 OF 4	M,N K,T	'04/5/25	材料 MATERIAL	SEE NOTE 2	MOLEX-JAPAN CO.,LTD. 日本モレックス株式会社	
MODEL NO.		H	SEE SHEET 1 OF 4	H,H M,F	'94/4/19	仕上げ FINISH	SEE NOTE 2	REVISE ONLY ON CAD SYSTEM	
角度 ANGLE	+3°	G	SEE SHEET 1 OF 4	H,H Y,Y	'91/3/7	適用電線範囲 WIRE RANGE	—#—	TITLE 名称 NEW MINI FIT CONNECTOR HEADER HOUSING ASS'Y -LEAD FREE-	
30 以上 OVER	+0.3	F	SEE SHEET 1 OF 4	H,H Y,Y	'90/6/8	被覆外径 INS. RANGE			
10 以上 OVER 30 UNDER	+0.25	E	SEE SHEET 1 OF 4	H,H Y,Y	'89/8/25				
未満 UNDER	+0.2	D	SEE SHEET 1 OF 4	H,H Y,Y	'89/4/3	DRAWN BY '89/4/3 H.HIRAMOTO	CHK'D BY '94/4/20 M.FUKUSHIMA	DWG. NO. SHEET 2 OF 4 REV	
一般公差 GENERAL TOLERANCES		記号 LTR	変更内容 REVISION RECORD	DR. CHK.	日付 DATE	尺度 SCALE	—#—	SD-5566-N****-*	

8		7		6		5		4		3		2		1	
DWG. NO. SD-5566-N****-*	NOT TOOLED	5566-24BGS2-310	NOT TOOLED	5566-24BGS-310	NOT TOOLED	5566-24BS-310	NOT TOOLED	5566-24B-310	NOT TOOLED	5566-24B-310	NOT TOOLED	5566-24APBS-310	24		
	↑	↑	↑	↑	↑	↑	↑	↑	↑	↑	↑	↑	22		
		-22BGS2-310		-22BGS-310		-22BS-310		-22B-310		-22B-310		-22APBS-310	20		
		-20BGS2-310		-20BGS-310		-20BS-310		-20B-310		-20B-310		-20APBS-310	18		
		-18BGS2-310		-18BGS-310		-18BS-310		-18B-310		-18B-310		-18APBS-310	16		
		-16BGS2-310		-16BGS-310		-16BS-310		-16B-310		-16B-310		-16APBS-310	14		
		-14BGS2-310		-14BGS-310		-14BS-310		-14B-310		-14B-310		-14APBS-310	12		
		-12BGS2-310		-12BGS-310		-12BS-310		-12B-310		-12B-310		-12APBS-310	10		
		-10BGS2-310		-10BGS-310		-10BS-310		-10B-310		-10B-310		-10APBS-310	8		
		-08BGS2-310		-08BGS-310		-08BS-310		-08B-310		-08B-310		-08APBS-310	6		
	-06BGS2-310		-06BGS-310		-06BS-310		-06B-310		-06B-310		-06APBS-310	4			
	-04BGS2-310		-04BGS-310		-04BS-310		-04B-310		-04B-310		-04APBS-310	2			
	↓	↓	↓	↓	↓	↓	↓	↓	↓	↓	↓	2			
	EDP NO.	ENG. NO.	EDP NO.	ENG. NO.	EDP NO.	ENG. NO.	EDP NO.	ENG. NO.	EDP NO.	ENG. NO.	EDP NO.	ENG. NO.	CKT. SIZE		
	5566-NBGS2-310	5566-NBGS-310	5566-NBS-310	5566-NB-310	5566-NAPBS-310										
	39-30-9247	5566-24BGS2-210	39-31-0248	5566-24BGS-210	39-31-0242	5566-24BS-210	39-31-0240	5566-24B-210	39-30-6244	5566-24APBS-210		24			
	↑	↑	↑	↑	↑	↑	↑	↑	↑	↑	↑	22			
	-9227	-22BGS2-210	-0228	-22BGS-210	-0222	-22BS-210	-0220	-22B-210	-6224	-22APBS-210		20			
	-9207	-20BGS2-210	-0208	-20BGS-210	-0202	-20BS-210	-0200	-20B-210	-6204	-20APBS-210		18			
	-9187	-18BGS2-210	-0188	-18BGS-210	-0182	-18BS-210	-0180	-18B-210	-6184	-18APBS-210		16			
	-9167	-16BGS2-210	-0168	-16BGS-210	-0162	-16BS-210	-0160	-16B-210	-6164	-16APBS-210		14			
	-9147	-14BGS2-210	-0148	-14BGS-210	-0142	-14BS-210	-0140	-14B-210	-6144	-14APBS-210		12			
	-9127	-12BGS2-210	-0128	-12BGS-210	-0122	-12BS-210	-0120	-12B-210	-6124	-12APBS-210		10			
	-9107	-10BGS2-210	-0108	-10BGS-210	-0102	-10BS-210	-0100	-10B-210	-6104	-10APBS-210		8			
	-9087	-08BGS2-210	-0088	-08BGS-210	-0082	-08BS-210	-0080	-08B-210	-6084	-08APBS-210		6			
	-9067	-06BGS2-210	-0068	-06BGS-210	-0062	-06BS-210	-0060	-06B-210	-6064	-06APBS-210		4			
	-9047	-04BGS2-210	-0048	-04BGS-210	-0042	-04BS-210	-0040	-04B-210	-6044	-04APBS-210		2			
	↓	↓	↓	↓	↓	↓	↓	↓	↓	↓	↓	2			
	39-30-9027	5566-02BGS2-210	39-31-0028	5566-02BGS-210	39-31-0022	5566-02BS-210	39-31-0020	5566-02B-210	39-30-6024	5566-02APBS-210		24			
	↑	↑	↑	↑	↑	↑	↑	↑	↑	↑	↑	22			
	-9226	-22BGS2	-0227	-22BGS	-0221	-22BS	-3226	-22B	-6223	-22APBS		20			
	-9206	-20BGS2	-0207	-20BGS	-0201	-20BS	-3206	-20B	-6203	-20APBS		18			
	-9186	-18BGS2	-0187	-18BGS	-0181	-18BS	-3186	-18B	-6183	-18APBS		16			
	-9166	-16BGS2	-0164	-16BGS	-0161	-16BS	-3166	-16B	-6163	-16APBS		14			
	-9146	-14BGS2	-0147	-14BGS	-0141	-14BS	-3146	-14B	-6143	-14APBS		12			
	-9126	-12BGS2	-0127	-12BGS	-0121	-12BS	-3126	-12B	-6123	-12APBS		10			
	-9106	-10BGS2	-0107	-10BGS	-0101	-10BS	-3106	-10B	-6103	-10APBS		8			
	-9086	-08BGS2	-0087	-08BGS	-0081	-08BS	-3086	-08B	-6083	-08APBS		6			
	-9066	-06BGS2	-0067	-06BGS	-0061	-06BS	-3066	-06B	-6063	-06APBS		4			
	-9046	-04BGS2	-0047	-04BGS	-0041	-04BS	-3046	-04B	-6043	-04APBS		2			
	↓	↓	↓	↓	↓	↓	↓	↓	↓	↓	↓	2			
	39-30-9026	5566-02BGS2	39-31-0027	5566-02BGS	39-31-0021	5566-02BS	39-29-3026	5566-02B	39-30-6023	5566-02APBS		24			
	↑	↑	↑	↑	↑	↑	↑	↑	↑	↑	↑	22			
	EDP NO.	ENG. NO.	EDP NO.	ENG. NO.	EDP NO.	ENG. NO.	EDP NO.	ENG. NO.	EDP NO.	ENG. NO.	EDP NO.	ENG. NO.	CKT. SIZE		
	5566-NBGS2	5566-NBGS	5566-NBS	5566-NB	5566-NAPBS										

DIMENSIONS IN METRIC DO NOT SCALE DRAWING

5566-N****		J	SEE SHEET 1 OF 4	M,N K,T	04/5/25	材料 MATERIAL	SEE NOTE 2	MOLEX-JAPAN CO.,LTD. 日本モレックス株式会社	
MODEL NO.		H	SEE SHEET 1 OF 4	H,H M,F	94/4/19	仕上げ FINISH	SEE NOTE 2	REVISE ONLY ON CAD SYSTEM	
角度 ANGLE		G	SEE SHEET 1 OF 4	H,H Y,Y	91/3/7	適用電線範囲 WIRE RANGE	—	TITLE 名称	
30以上 OVER		F	SEE SHEET 1 OF 4	H,H Y,Y	90/6/8	被覆外径 INS. RANGE	—	NEW MINI FIT CONNECTOR HEADER HOUSING ASS'Y -LEAD FREE-	
10以上 OVER 30 UNDER		E	SEE SHEET 1 OF 4	H,H Y,Y	89/8/25	DRAWN BY '89/4/3 H.HIRAMOTO	CHK'D BY '94/4/20 M.FUKUSHIMA	DWG. NO. SHEET 3 OF 4 REV	
未滿 UNDER		D	SEE SHEET 1 OF 4	H,H Y,Y	89/4/3	APP'D BY '94/4/20 M.FUKUSHIMA	尺度 SCALE	SD-5566-N****-*	
一般公差 GENERAL TOLERANCES		記号 LTR	変更内容 REVISION RECORD	DR. CHK.	日付 DATE				

DWG. NO.
SD-5566-N****-

E

D

C

B

A

DIMENSIONS IN METRIC DO NOT SCALE DRAWING

8		7		6		5		4		3		2		1	
NOT	TOOLED	5566-24BPBS-310				NOT	TOOLED	5566-24BPB-310				24			
	▲	▲	▲	▲	▲	▲	▲	▲	▲	▲	▲	▲	▲	▲	22
															20
															18
															16
															14
															12
															10
															8
															6
															4
	▼	▼	▼	▼	▼	▼	▼	▼	▼	▼	▼	▼	▼	▼	2
NOT TOOLED		5566-02BPBS-310				NOT TOOLED		5566-02BPB-310				2			
EDP NO.		ENG. NO				EDP NO.		ENG. NO				CKT. SIZE			
39-31-0246		5566-24BPBS-210				39-31-0244		5566-24BPB-210				24			
	▲	▲	▲	▲	▲	▲	▲	▲	▲	▲	▲	▲	▲	▲	22
															20
															18
															16
															14
															12
															10
															8
															6
	▼	▼	▼	▼	▼	▼	▼	▼	▼	▼	▼	▼	▼	▼	4
39-31-0026		5566-02BPBS-210				39-31-0024		5566-02BPB-210				2			
EDP NO.		ENG. NO				EDP NO.		ENG. NO				CKT. SIZE			
39-31-0026		5566-02BPBS-210				39-31-0024		5566-02BPB-210				2			
EDP NO.		ENG. NO				EDP NO.		ENG. NO				CKT. SIZE			
39-35-0248		5566-24A-400				39-31-0245		5566-24BPBS				24			
	▲	▲	▲	▲	▲	▲	▲	▲	▲	▲	▲	▲	▲	▲	22
															20
															18
															16
															14
															12
															10
															8
															6
	▼	▼	▼	▼	▼	▼	▼	▼	▼	▼	▼	▼	▼	▼	4
39-35-0028		5566-02A-400				39-31-0025		5566-02BPBS				2			
EDP NO.		ENG. NO				EDP NO.		ENG. NO				CKT. SIZE			
39-35-0028		5566-02A-400				39-31-0025		5566-02BPBS				2			
EDP NO.		ENG. NO				EDP NO.		ENG. NO				CKT. SIZE			
5566-NA-400		5566-NBPBS				5566-NBPBS		5566-NBPB				24			

39-35-0248	5566-24A-400	39-31-0245	5566-24BPBS	39-31-0243	5566-24BPB	24
▲ -0228	▲ -22A-400	▲ -0225	▲ -22BPBS	▲ -0223	▲ -22BPB	
-0208	-20A-400	-0205	-20BPBS	-0203	-20BPB	
-0188	-18A-400	-0185	-18BPBS	-0183	-18BPB	
-0168	-16A-400	-0165	-16BPBS	-0163	-16BPB	
-0148	-14A-400	-0145	-14BPBS	-0143	-14BPB	
-0128	-12A-400	-0125	-12BPBS	-0123	-12BPB	
-0108	-10A-400	-0105	-10BPBS	-0103	-10BPB	
-0088	-08A-400	-0085	-08BPBS	-0083	-08BPB	
-0068	-06A-400	-0065	-06BPBS	-0063	-06BPB	
▼ -0048	▼ -04A-400	▼ -0045	▼ -04BPBS	▼ -0043	▼ -04BPB	
39-35-0028	5566-02A-400	39-31-0025	5566-02BPBS	39-31-0023	5566-02BPB	
EDP NO.	ENG. NO	EDP NO.	ENG. NO	EDP NO.	ENG. NO	
5566-NA-400	5566-NBPBS	5566-NBPBS	5566-NBPBS	5566-NBPB	5566-NBPB	

5566-N****-		J	SEE SHEET 1 OF 4	M,N K,T	04/5/25	材料 MATERIAL	SEE NOTE 2	MOLEX-JAPAN CO.,LTD. 日本モレックス株式会社
MODEL NO.	H	SEE SHEET 1 OF 4	H,L M,F	94/4/19	仕上げ FINISH	SEE NOTE 2	REVISE ONLY ON CAD SYSTEM	
角度 ANGLE	30°	G	SEE SHEET 1 OF 4	H,L Y,Y	91/3/7	適用電線範囲 WIRE RANGE	TITLE 名称	
30以上 OVER	+0.3	F	SEE SHEET 1 OF 4	H,L Y,Y	90/6/8	被覆外径 INS. RANGE	NEW MINI FIT CONNECTOR HEADER HOUSING ASS'Y -LEAD FREE-	
10以上 30未満 OVER UNDER	+0.25	E	SEE SHEET 1 OF 4	H,L Y,Y	89/8/25	DRAWN BY '89/4/3 H.HIRAMOTO	CHK'D BY '94/4/20 M.FUKUSHIMA	
10未満 UNDER	+0.2	D	SEE SHEET 1 OF 4	H,L Y,Y	89/4/3	DR. 記号 LTR	DR. 変更内容 REVISION RECORD	
一般公差 GENERAL TOLERANCES						DR. 日付 DATE	DR. 尺度 SCALE	

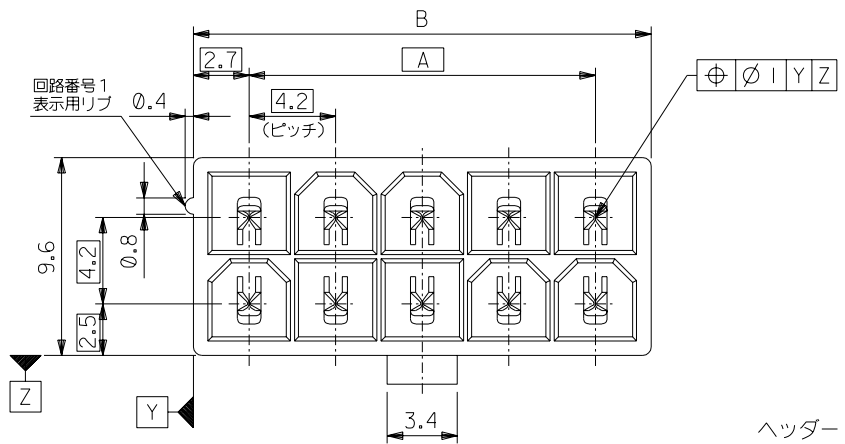

51.6	46.2	24
47.4	42	22
43.2	37.8	20
39	33.6	18
34.8	29.4	16
30.6	25.2	14
26.4	21	12
22.2	16.8	10
18	12.6	8
13.8	8.4	6
9.6	4.2	4
5.4	—	2
寸法 B	寸法 A	極数

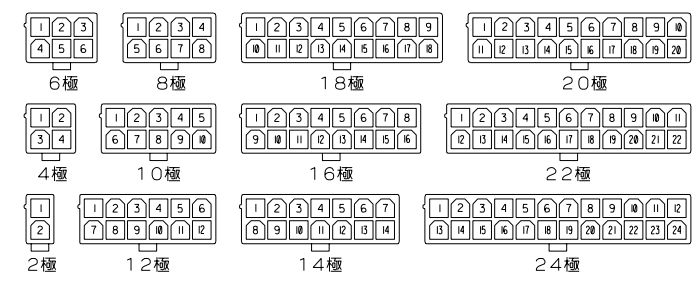

極数別レイアウト図
(SCALE 1:1)

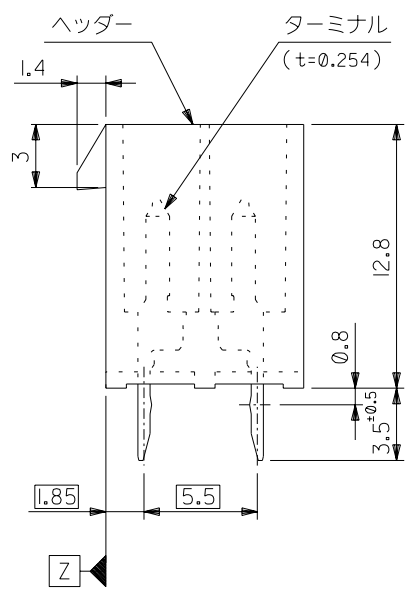
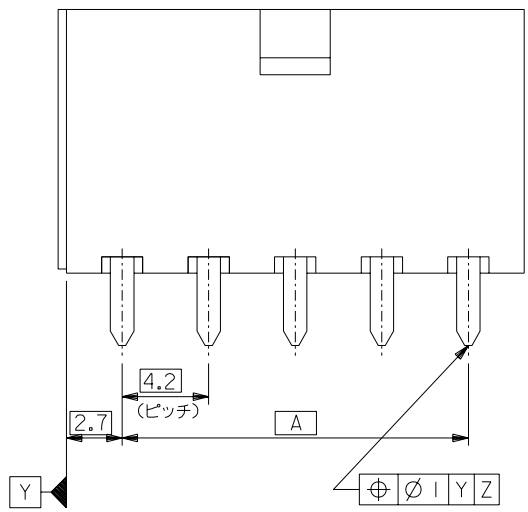

注 記

- 嵌合相手：5557シリーズ
- 使用符号の説明
 ベースナンバー 5566 - N A * * - *
 極数 _____
 アッセンブリ _____
 ターミナル材料 _____
 "BLANK"：黄銅
 PB：リン青銅
 ターミナルのメッキ _____
 "BLANK"：錫メッキ 0.9μm MIN.
 GS：ニッケル 1.27μm MIN. 全面下地
 コンタクト部 金 0.76μm MIN.
 半田付け部 錫 2.54μm MIN.
 ヘッダー材料 _____
 "BLANK"：ナイロン 66, UL 94V-2
 210：ナイロン 66, UL 94V-0
 400：ナイロン 66, UL 94V-0, 黒

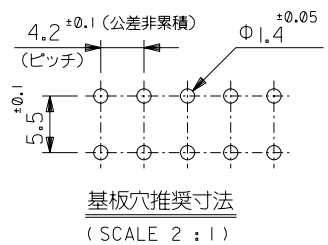

5566-NA***
MODEL NO.

材料 MATERIAL		注記 2 参照		MOLEX-JAPAN CO.,LTD. 日本モレックス株式会社	
仕上げ FINISH		注記 2 参照		EDP NO. SHEET 2 OF 2 参照	
角度 ANGLE	±3°	F 変更 (J2004-4431)	M.N. '04/5/26	適用電線範囲 WIRE RANGE	—
30以上 OVER	±0.4	E 変更 (J00638)	H.H. '90/6/8	被覆外径 INS. RANGE	—
10以上 OVER 30未満 UNDER	±0.3	D 変更&再作図 (J00510)	H.H. '90/5/7	DRAWN BY '89/5/7	CHK'D BY '91/10/29
10未満 UNDER	±0.2	記号 変更内容 REVISION RECORD	DR. CHK. 日付 DATE	APP'D BY '91/10/29	M.FUKUSHIMA
一般公差 GENERAL TOLERANCES	REVISION RECORD	REVISE ONLY ON CAD SYSTEM		M.ENOMOTO	
				TITLE 名称 NEW MINI FIT CONNECTOR HEADER ASS'Y -LEAD FREE-	

ENG. NO
SD-5566-NA***

EDP NO.
表 参照

MM DIMENSIONS IN METRIC DO NOT SCALE DRAWING

39-35-0248	5566-24A-400	24
▲ -0228	▲ -22A-400	22
-0208	-20A-400	20
-0188	-18A-400	18
-0168	-16A-400	16
-0148	-14A-400	14
-0128	-12A-400	12
-0108	-10A-400	10
-0088	-08A-400	8
-0068	-06A-400	6
▼ -0048	▼ -04A-400	4
39-35-0028	5566-02A-400	2
EDP NO.	ENG. NO	極数
5566-NA-400		極数

39-29-5247	5566-24APB-210	39-29-6248	5566-24AGS-210	39-28-8240	5566-24A-210	24
▲ -5227	▲ -22APB-210	▲ -6228	▲ -22AGS-210	▲ -8220	▲ -22A-210	22
-5207	-20APB-210	-6208	-20AGS-210	-8200	-20A-210	20
-5187	-18APB-210	-6188	-18AGS-210	-8180	-18A-210	18
-5167	-16APB-210	-6168	-16AGS-210	-8160	-16A-210	16
-5147	-14APB-210	-6148	-14AGS-210	-8140	-14A-210	14
-5127	-12APB-210	-6128	-12AGS-210	-8120	-12A-210	12
-5107	-10APB-210	-6108	-10AGS-210	-8100	-10A-210	10
-5087	-08APB-210	-6088	-08AGS-210	-8080	-08A-210	8
-5067	-06APB-210	-6068	-06AGS-210	-8060	-06A-210	6
▼ -5047	▼ -04APB-210	▼ -6048	▼ -04AGS-210	▼ -8040	▼ -04A-210	4
39-29-5027	5566-02APB-210	39-29-6028	5566-02AGS-210	39-28-8020	5566-02A-210	2
EDP NO.	ENG. NO	EDP NO.	ENG. NO	EDP NO.	ENG. NO	極数
5566-NAPB-210		5566-NAGS-210		5566-NA-210		極数
39-29-5246	5566-24APB	39-29-0243	5566-24AGS	39-28-1243	5566-24A	24
▲ -5226	▲ -22APB	▲ -0223	▲ -22AGS	▲ -1223	▲ -22A	22
-5206	-20APB	-0203	-20AGS	-1203	-20A	20
-5186	-18APB	-0183	-18AGS	-1183	-18A	18
-5166	-16APB	-0163	-16AGS	-1163	-16A	16
-5146	-14APB	-0143	-14AGS	-1143	-14A	14
-5126	-12APB	-0123	-12AGS	-1123	-12A	12
-5106	-10APB	-0103	-10AGS	-1103	-10A	10
-5086	-08APB	-0083	-08AGS	-1083	-08A	8
-5066	-06APB	-0063	-06AGS	-1063	-06A	6
▼ -5046	▼ -04APB	▼ -0043	▼ -04AGS	▼ -1043	▼ -04A	4
39-29-5026	5566-02APB	39-29-0023	5566-02AGS	39-28-1023	5566-02A	2
EDP NO.	ENG. NO	EDP NO.	ENG. NO	EDP NO.	ENG. NO	極数
5566-NAPB		5566-NAGS		5566-NA		極数

5566-NA***		材料 MATERIAL		注記 2 参照		MOLEX-JAPAN CO.,LTD. 日本モレックス株式会社			
MODEL NO.		仕上げ FINISH		注記 2 参照		EDP. NO. 表 参照			
角度 ANGLE	+3°	F	SEE SHEET 1 OF 2	M.N. K.T.	'04/5/26	適用電線範囲 WIRE RANGE	—H—	ENG. NO. SHEET 2 OF 2	REV F
30 以上 OVER	+0.3	E	SEE SHEET 1 OF 2	H.H.	'90/6/8	被覆外径 INS. RANGE		SD-5566-NA***	
10 以上 OVER 30 未満 UNDER	+0.25	D	SEE SHEET 1 OF 2	H.H. Y.Y.	'90/5/7	DRAWN BY '90/5/7	CHK'D BY '91/10/29	TITLE 名称 NEW MINI FIT CONNECTOR HEADER ASS'Y -LEAD FREE-	
10 未満 UNDER	+0.2	記号 LTR	変更内容 REVISION RECORD	DR. CHK.	日付 DATE	H.HIRAMOTO	M.FUKUSHIMA	尺度 SCALE —H—	
一般公差 GENERAL TOLERANCES		REVISE ONLY ON CAD SYSTEM						MENOMOTO	

5566-S22