

**Switch Language**

English

**Need Assistance?**

- [Contact Us](#)
- [Find a Distributor](#)
- [Order Samples](#)
- [Tech Library](#)

[Printer-friendly page](#)

[Email this page](#)

[Home](#)   [Ring and Spade Terminals](#)   [Datasheet](#)

**Part Number: 0190690049**

**Status: Active**

**Description:** Krimptite™ Ring Tongue Terminal for 18-22 AWG Wire

**Documents:**

*Note - Please disable browser pop-up blockers for documents on www.molex.com*

[Drawing \(PDF\)](#)

[Related Catalog Page \(PDF\)](#)

**Order Products:**

[Check Distributor Inventory](#)

[Add to My Parts](#)

[Request Samples](#)

**Part Detail:** [\(show all\)](#)

[General](#)   [Physical](#)   [Electrical](#)   [Material Info](#)

**General**

Product Family	Ring and Spade Terminals
Series	<a href="#">19069</a>
Mil-Spec	N/A
Product Name	Krimptite™
Type	Ring

**Physical**

Barrel Type	Closed
Insulation	None
Material - Plating Mating	Tin
Packaging Type	Bag
Stud Size	3/8" (M9)
Termination Interface: Style	Crimp or Compression
Wire Size AWG	18
Wire Size AWG	20
Wire Size AWG	22
Wire Size mm²	0.35 - 0.80

**Electrical**

CSA	LR18689
UL	E32244

**Material Info**

Old Part Number	AA-126-38
-----------------	-----------

**Reference - Drawing Numbers**

Sales Drawing	SD-19069-004
---------------	--------------

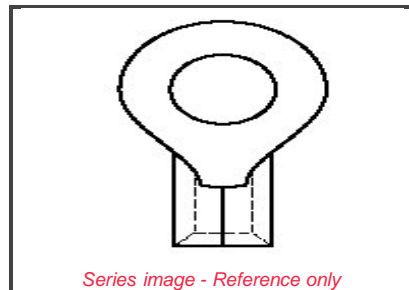

**EU RoHS**

**ELV and RoHS Compliant**

**China RoHS**



**Need more information on product compliance?**

Email [productcompliance@molex.com](mailto:productcompliance@molex.com)

Please visit the [Contact Us](#) section for any non-product compliance questions.

**Search Parts in this Series**

[19069](#) Series

**Application Tooling**

*Tooling specifications and manuals are found by selecting the products below. Crimp Height Specifications are then contained in the Application Tooling Specification document.*

**Global**

Description	Product #
Hand Crimp Tool	<a href="#">0640030100</a>
Crimp Head for the AT-200™ Pneumatic Hand Tool	<a href="#">0640070100</a>

	10	9	8	7	6	5	4	3	2	1		
	MATERIAL NO. LOOSE PIECE	ENG. NO.	MATERIAL NO. TAPE MOUNTED	ENG. NO.	STUD SIZE	"S" ±.003/(0.08)	"W" MAX.	"C" MIN.	"L" MAX.	"ID" MIN.	STOCK THICKNESS	"H" ±.020/0.51
F	190690027	AA-120-02	190690028	AA-120-02T	2	.094/(2.39)	.235/(6.00)	.157/(3.99)	.484/(12.29)	.062/(1.57)	.028/(0.71)	1.155/(29.34)
	190690029	AA-120-04	190690030	AA-120-04T	4	.119/(3.02)						
	190690031	AA-120-06	190690032	AA-120-06T	6	.146/(3.71)						
	190690033	AA-121-06	190690034	AA-121-06T	6	.146/(3.71)						
	190690035	AA-121-08	190690036	AA-121-08T	8	.173/(4.39)						
	190690037	AA-121-10	190690038	AA-121-10T	10	.198/(5.03)						
	190690039	AA-121-209	190690475	AA-121-209T	209	.209/(5.18)	.322/(8.18)	.270/(6.86)	.641/(16.28)	.062/(1.57)	.028/(0.71)	
E	190690040	AA-122-10	190690041	AA-122-10T	10	.198/(5.03)						
	190690042	AA-122-14	190690044	AA-122-14T	14	Ⓢ.265/(6.71)	.477/(12.11)	.386/(9.80)	.835/(21.21)	.062/(1.57)	.028/(0.71)	
	190690045	AA-122-56	190690046	AA-122-56T	56	.328/(8.33)						
	190690047	AA-126-10	-----	-----	10	Ⓢ.198/(5.03)	.544/(13.82)	.552/(14.02)	1.034/(26.26)	.055/(1.40)	.031/(0.79)	
	190690048	AA-126-14	190690128	AA-126-14T	14	Ⓢ.265/(6.71)						
	190690051	AA-126-56	-----	-----	56	.328/(8.33)	.264/(6.70)	.240/(6.10)	.582/(14.78)	.062/(1.57)	.028/(0.71)	
D	190690049	AA-126-38	190690050	AA-126-38T	38	.390/(9.91)						
	190690052	AA-132-04	190690053	AA-132-04T	4	.119/(3.02)	.283/(7.20)	.240/(6.10)	.591/(15.00)	.062/(1.57)	.028/(0.71)	
	190690054	AA-132-06	190690055	AA-132-06T	6	.146/(3.71)						
	190690056	AA-132-08	190690057	AA-132-08T	8	.146/(3.71)	.197/(5.00)	.173/(4.40)	.490/(12.40)	.055/(1.40)	.031/(0.79)	
	190690061	AA-133-10	190690062	AA-133-10T	10	.198/(5.03)						
	190690024	AA-1111-02	190690191	AA-1111-02T	2	.094/(2.39)	.119/(3.02)					
	190690025	AA-1111-04	190690026	AA-1111-04T	4	.119/(3.02)						

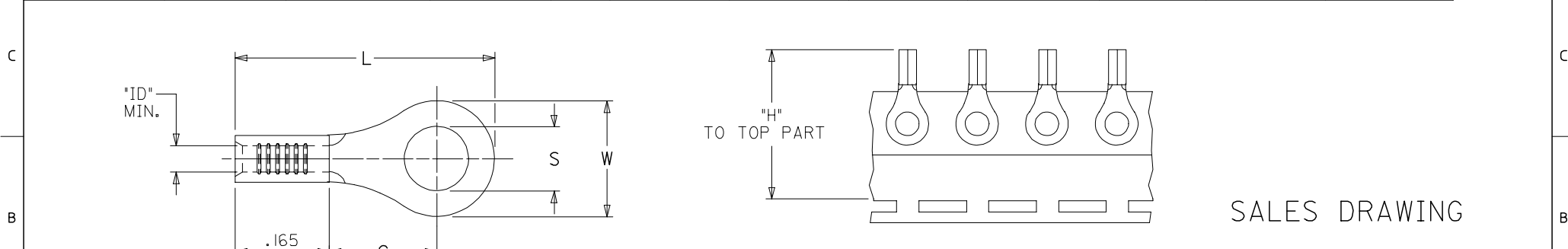

SALES DRAWING

NOTE(S):  
 1. MATERIAL: COPPER.  
 2. PLATING: ELECTRO-TIN.  
 3. ALL DIMENSIONS IN INCHES/(MM).  
 WIRE SIZE:  
 22-18 AWG  
 0.25-1.5 MM<sup>2</sup>

.265 DIM WAS .256 EC NO: ETC2006-0015 DRWNG: JYR1 CK 2005/07/22 CHKD: JPAW1 CK 2005/07/22 APPR: JPAW1 CK 2005/07/25	QUALITY SYMBOLS	GENERAL TOLERANCES (UNLESS SPECIFIED) <table border="1"> <thead> <tr> <th></th> <th>mm</th> <th>INCH</th> </tr> </thead> <tbody> <tr> <td>4 PLACES</td> <td>± .005</td> <td>± .0005</td> </tr> <tr> <td>3 PLACES</td> <td>± .004</td> <td>± .0004</td> </tr> <tr> <td>2 PLACES</td> <td>± .003</td> <td>± .0003</td> </tr> <tr> <td>1 PLACE</td> <td>± .002</td> <td>± .0002</td> </tr> <tr> <td colspan="3">ANGULAR ± .005°</td> </tr> </tbody> </table>		mm	INCH	4 PLACES	± .005	± .0005	3 PLACES	± .004	± .0004	2 PLACES	± .003	± .0003	1 PLACE	± .002	± .0002	ANGULAR ± .005°			DIMENSION STYLE	SCALE	DESIGN UNITS	THIRD ANGLE PROJECTION
			mm	INCH																				
	4 PLACES		± .005	± .0005																				
	3 PLACES		± .004	± .0004																				
2 PLACES	± .003	± .0003																						
1 PLACE	± .002	± .0002																						
ANGULAR ± .005°																								
	IN/MM	---	INCH																					
	DRAWN BY	DATE	TITLE																					
	DATE	DATE																						
	DESCRIPTION	APPROVED BY	DATE	RING TONGUE TERMINAL KRIMPITE, 100 SERIES 22-18 AWG																				
	REV	RDEROSS	2000/6/13	MOLEX INCORPORATED																				
		MATERIAL NO.	DATE	DOCUMENT NO.	SHEET NO.																			
		SEE CHART	2000/6/13	SD-19069-004	1 OF 1																			
		SIZE	THIS DRAWING CONTAINS INFORMATION THAT IS PROPRIETARY TO MOLEX INCORPORATED AND SHOULD NOT BE USED WITHOUT WRITTEN PERMISSION																					
		B																						