

Part Number: [0008550129](#)
Status: **Active - Custom**
Description: KK® High Pressure Crimp Terminal 7879, 22-30 AWG, Bag Selective Gold (Au)

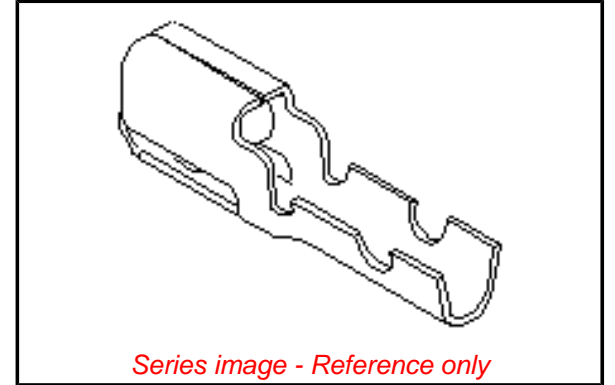

General

Product Family	Crimp Terminals
Series	<u>7879</u>
Product Name	KK® High Pressure

Physical

Gender	Female
Material - Metal	Brass
Material - Plating Mating	Gold
Material - Plating Termination	Tin
Packaging Type	Bag
Plating min: Mating (µin)	15
Plating min: Mating (µm)	0.38
Plating min: Termination (µin)	100
Plating min: Termination (µm)	2.50
Termination Interface: Style	Crimp or Compression
Wire Insulation Diameter	1.57mm (.062") max.
Wire Size AWG	22
Wire Size AWG	24
Wire Size AWG	26
Wire Size AWG	28
Wire Size AWG	30
Wire Size mm²	N/A

Material Info

Old Part Number	7879-1(P208)L
-----------------	---------------

EU RoHS

**ELV and RoHS
Compliant**

China RoHS



NOTES:

1. MATERIAL:
 - 1) 70/30 BRASS, PER ES-124C-6.
 - 2) PHOS. BRONZE, PER ES-124E-5.
2. FINISH: SEE LEGEND.
3. THIS PART CONFORMS TO PRODUCT SPEC. 7879.
4. CRIMP FOR 24-30 AWG. WIRE WITH .060/(1.52) MAX. INSULATION DIA.
5. THIS TERMINAL TO BE USED IN 7880 HOUSING.
6. DIMENSIONS GIVEN ACROSS CENTERLINES ARE SYMMETRICAL ABOUT THOSE CENTERLINES WITHIN HALF THE TOTAL TOLERANCE.
7. CRIMP WILL ACCEPT 22 AWG. WIRE WITH .062/(1.57) MAX. INSULATION DIA.

LEGEND:

MATERIAL
 (.20^{+0.000}_{-.020}) / .008^{+0.0000}_{-.0008} THICK

7879-*(***)*

PLATING

WINDING SPEC.
 BLANK= PER ES-339-B
 L= LOOSE

70/30 BRASS, PER ES-124C-6.
 2= PHOS. BRONZE, PER ES-124E-5.

(102) OVERALL TIN: .000200/(0.00508) MIN. OVER .000100/(0.00254) MIN. COPPER.
 *(P909) OVERALL HOT TN DP: .000100/(0.00254) MIN.
 (P154) OVERALL TIN: .000100/(0.00254) MIN. OVERALL NICKEL UNDERPLATE: .000050/(0.00127) MIN.
 (208) SELECT GOLD: .000015/(0.00038) MIN.
 *SELECT TIN: .000100/(0.00254) MIN.
 OVERALL NICKEL UNDERPLATE: .000050/(0.00127) MIN.
 (228) SELECT GOLD: .000030/(0.00076) MIN.
 *SELECT TIN: .000100/(0.00254) MIN.
 OVERALL NICKEL UNDERPLATE: .000050/(0.00127) MIN.

*THE PRIMARY SHIPPING CARTON WILL BE LABELED 'COMPLIANT TO RoHS DIRECTIVE 2002/95/EC AND ELV ANNEX II OF DIRECTIVE 2000/53/EC.' CARTONS WITHOUT THIS LABEL MAY CONTAIN PRODUCT WITH TIN-LEAD PLATING.

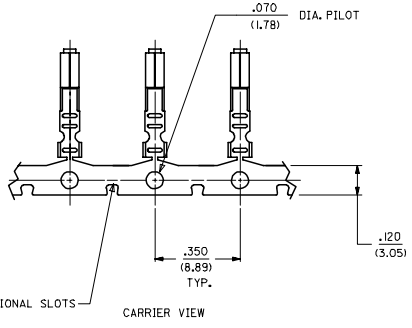
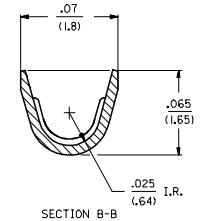
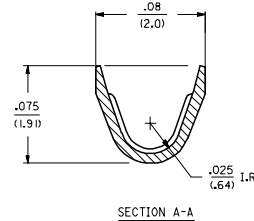
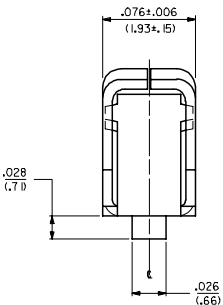
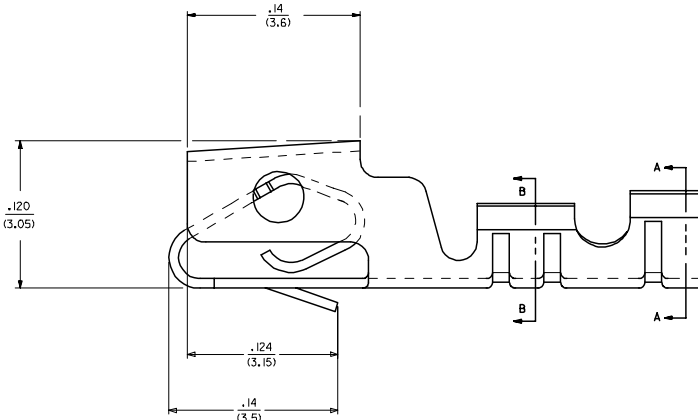
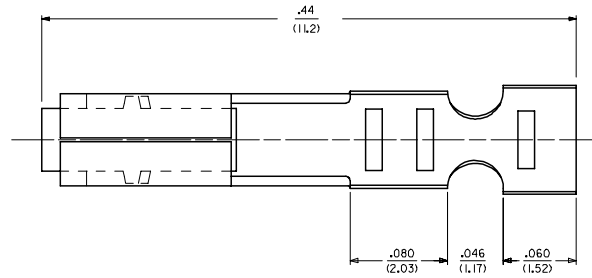

ADD EDP NO'S DEC NO: UCP2006-1006 2006/03/01 DORNWALDLAG 2006/03/23 CHPKADDER 2006/03/23 APPR:ESMTJH ZZ	QUALITY SYMBOLS ▽=0 ▽=0	GENERAL TOLERANCES (UNLESS SPECIFIED)		DIMENSION STYLE IN/MM		SCALE	DESIGN UNITS	THIRD ANGLE PROJECTION
		mm	INCH	DRAWN BY	DATE	(2.54)/.100 KK, CRIMP TYPE SHROUDED TERMINAL	INCH	
		4 PLACES ± .005	± .005	GUZIK	12/22/88			
		3 PLACES ± .010	± .010	CHECKED BY	DATE			
2 PLACES ± 0.25	± .014	PATEL	12/22/88					
1 PLACE ± 0.36	± .014	APPROVED BY	DATE	MOLEX INCORPORATED				
ANGULAR ±1/2°		LENZ	12/22/88					
DRAFT WHERE APPLICABLE MUST REMAIN WITHIN DIMENSIONS		SEE CHART		MATERIAL NO. DOCUMENT NO.		SHEET NO.		
		SIZE D		THIS DRAWING CONTAINS INFORMATION THAT IS PROPRIETARY TO MOLEX INCORPORATED AND SHOULD NOT BE USED WITHOUT WRITTEN PERMISSION		1 OF 2		

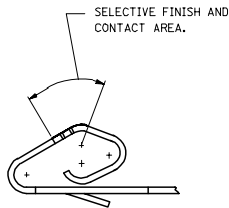

7879-1(***)*			7879-2(***)*		
PART NO.	ENG. NO		PART NO.	ENG. NO	
S 08-55-0128	7879-1P909I	PER ES-7879	50-29-1744	7879-2IP228I	PER ES-7879
S 08-55-0127	7879-1P909L	PER ES-7879	50-29-1745	7879-2IP228L	PER ES-7879
08-55-0124	7879-1P208	PER ES-7879		7879-2IP102I	PER ES-7879
				7879-2IP102L	PER ES-7879
08-55-0129	7879-1P208L	PER ES-7879			
08-50-0004	7879-1P102I	PER ES-7879			
08-50-0005	7879-1P102L	PER ES-7879			
50-29-1900	7879-1P154I	PER ES-7879			

COLUMN NO. 1	CONT. IN COLUMN NO.	SHEET NO.	COLUMN NO. 2	CONT. IN COLUMN NO.	SHEET NO.	COLUMN NO. 3	CONT. IN COLUMN NO.	SHEET NO.
--------------	---------------------	-----------	--------------	---------------------	-----------	--------------	---------------------	-----------

ADD EDP NO'S REC NO: UCP2006-1006 2006/09/01 JORWNAELHAG 2006/09/29 CHKCADDER 2006/09/29 APPR:ESH/TH	QUALITY SYMBOLS ▽=0 ▽=0	GENERAL TOLERANCES (UNLESS SPECIFIED)		DIMENSION STYLE IN/MM		SCALE ---	DESIGN UNITS INCH	<input checked="" type="checkbox"/> THIRD ANGLE PROJECTION
		4 PLACES ± --- ± --- 3 PLACES ± --- ± --- 2 PLACES ± --- ± --- 1 PLACE ± --- ± --- ANGULAR ±1/2°	mm INCH	DRAWN BY GUZIK DATE 12/22/88	CHECKED BY PATEL DATE 12/22/88	TITLE (2.54)/.100 KK, CRIMP TYPE SHROUDED TERMINAL		
DRAFT WHERE APPLICABLE MUST REMAIN WITHIN DIMENSIONS		SEE CHART		MATERIAL NO. LENZ DATE 12/22/88		MOLEX INCORPORATED		
		SIZE D		DOCUMENT NO. SD-7879		SHEET NO. 2		

2.54mm (.100") Pitch KK[®] Crimp Terminal

4809
Anti-Fishhooking

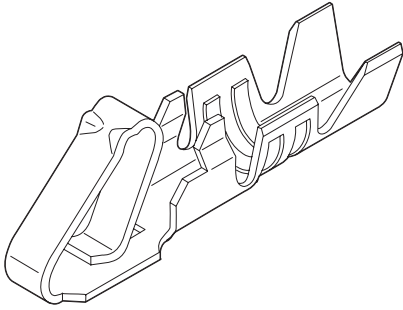

Features and Benefits

- Avoids tangling at pre-assembly
- Available with cat ears

Reference Information

Product Specification: PS-10-07
Packaging: Reel or bag
Tooling Information: See crimp tooling section
UL File No.: E29179
CSA File No.: LR19980
Mates With: 5051-NM and 6471 housings
Designed In: Inches

Electrical

Voltage: 250V
Current: 2.5A
Contact Resistance: 20 milliohms max.
Dielectric Withstanding Voltage: 1500V
Insulation Resistance: 500K Megohms min.

Mechanical

Contact Insertion Force: 681g max.
Contact Retention to Housing: 27.21g min.
Wire Pull-Out Force: 3 lb min.
Mating Force: 199g max.
Unmating Force: 57g min.
Normal Force: 300g
Durability: 50 cycles Gold and 25 cycles Tin

Physical

Contact: Brass
Plating: Gold, select Gold and Tin
Operating Temperature: Storage— -40 to +105°C
Operating— 0 to +75°C
Wire Accommodation: 22 to 30 AWG

Order No.		Plating	Crimp Wire Size	Insulation Diameter	Engineering No.	Lead-free
Bag	Reel					
08-50-0032	08-50-0031	1.00 to 2.50µm Tin	22-30	1.57 (.062) max.	4809	Yes
08-55-0111	08-55-0110	0.38µm Gold in contact area only				
08-56-0115	08-56-0120	0.38µm Gold in contact area, Gold flash overall				

2.54mm (.100") Pitch KK[®] Crimp Terminal

7879
High Pressure

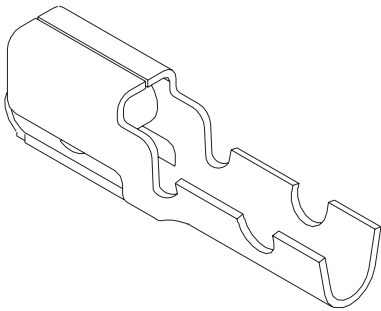

Features and Benefits

- Multiple contacting points
- Patented triple cantilever with box shroud
- Suitable for high vibration requirements
- Box shroud prevents contamination to the contact surface
- Crimping die or hand tool available

Reference Information

Product Specification: PS-7879
Packaging: Reel or bag
Tooling Information: See crimp tooling section
UL File No.: E29179
CSA File No.: LR19980
Use With: 7880 housings
Designed In: Inches

Electrical

Voltage: 250V
Current: 2.5A
Contact Resistance: 10 milliohms max.
Dielectric Withstanding Voltage: 1500V
Insulation Resistance: 50K Megohms min.

Mechanical

Wire Pull-Out Force:

Wire Gauge (AWG)	22	24	26	28	30
Pull-Out Force (lb)	10	8	6	4	3

Mating Force: 475g max.
Unmating Force: 100g min.
Normal Force: 430g min.

Physical

Contact: Brass
Plating: See Table
Wire Accommodation: 22 to 30 AWG
Insulation Range: 1.58mm (.062") diameter max.

Order No.		Plating	Wire Gauge (AWG)	Insulation Diameter	Lead-free
Reel	Bag				
08-50-0004	08-50-0005	Tin/Copper	22-30	1.57 (.062) max.	Yes
08-55-0124	08-55-0129	Select Gold			

Recommended wire range assumes stranded wire