

Part Number: [0008500108](#)
Status: **Active**
Overview: [KK®](#)
Description: 3.96mm (.156") Pitch KK® Crimp Terminal 2578, 22-26 AWG, Bag, Brass, Tin (Sn)

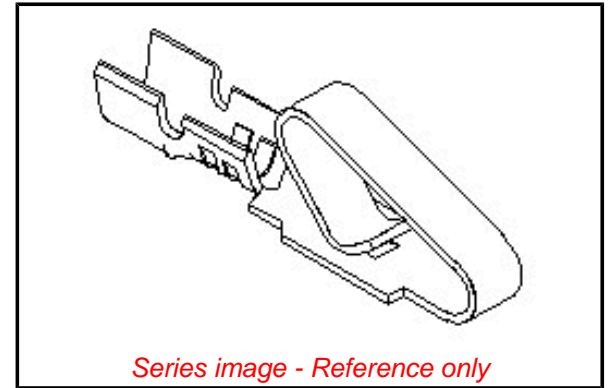

General

Product Family	Crimp Terminals
Series	2578
Overview	KK®
Product Name	KK®

Physical

Gender	Female
Material - Metal	Brass
Material - Plating Mating	Tin
Material - Plating Termination	Tin
Packaging Type	Bag
Plating min: Mating (µin)	100
Plating min: Mating (µm)	2.50
Plating min: Termination (µin)	100
Plating min: Termination (µm)	2.50
Termination Interface: Style	Crimp or Compression
Wire Insulation Diameter	1.65mm (.065") max.
Wire Size AWG	22
Wire Size AWG	24
Wire Size AWG	26
Wire Size mm²	N/A

Material Info

Old Part Number	2578-(P909)L
-----------------	--------------

EU RoHS

**ELV and RoHS
Compliant**

China RoHS



- NOTES:
1. CRIMP ACCEPTS 22 TO 26 GA. WIRE WITH (.165)/.065 MAX INSULATION DIA.
 2. DIMENSIONS GIVEN ACROSS CENTERLINES ARE SYMMETRICAL ABOUT THOSE CENTERLINES WITHIN HALF THE TOTAL TOLERANCE.
 3. OPTIONAL DESIGN (.86+.05)/.034+.002
 4. TERMINAL CONFORMS TO PRODUCT SPEC. 08-50.
 5. CAT EAR OPTION TO BE USED WITH 41695 HOUSING ONLY.

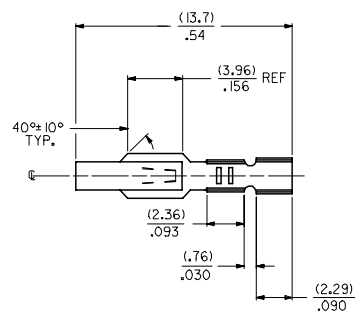
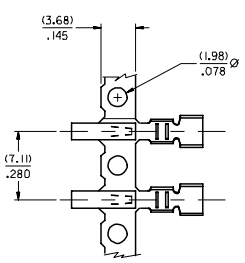
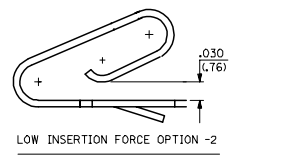
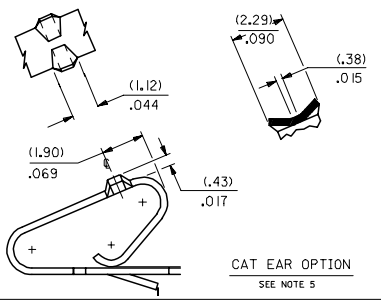

MATERIAL CODE
 (.28)/.0106 THK
 BLANK=BRASS
 B=PHOS BRONZE

WINDING SPEC.
 A=PER ES-339-A
 BLANK=PER ES-339-B
 L=LOOSE

PLATING CODE
 (PER SDES-88)
 *(P909) OVERALL HOT TIN DIP: 2.54 MICROMETERS MIN.
 (550) SELECT GOLD: 0.38 MICROMETERS MIN.
 OVERALL GOLD FLASH: 0.05 MICROMETERS MIN.
 OVERALL NICKEL UNDERPLATE: 0.76 MICROMETERS MIN.
 (555) SELECT GOLD: 0.38 MICROMETERS MIN.
 OVERALL NICKEL UNDERPLATE: 0.76 MICROMETERS MIN.

OPTIONS
 BLANK=AS SHOWN
 1=WITH CAT EARS
 2=LOW INSERTION FORCE

*THE PRIMARY SHIPPING CARTON WILL BE LABELED *COMPLIANT TO ROHS DIRECTIVE 2002/95/EC AND ELV ANNEX II OF DIRECTIVE 2000/53/EC.* CARTONS WITHOUT THIS LABEL MAY CONTAIN PRODUCT WITH TIN-LEAD PLATING.

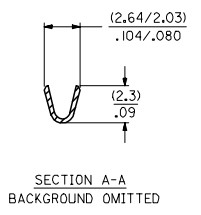
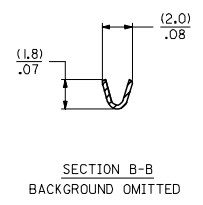
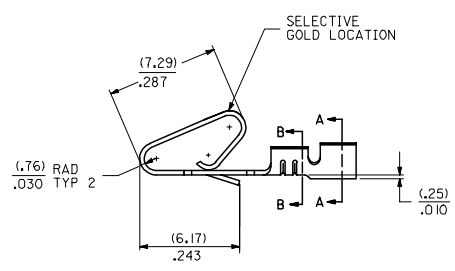
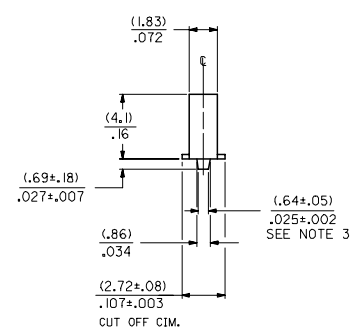

ENTER DESCRIPTION EC NO: UCP2005-0928 DRAWN BY: DRW:ADRIANO CHKD-SAMEC 2004/11/02 APPR:MMAGLIS 2004/11/02 W	QUALITY SYMBOLS	GENERAL TOLERANCES (UNLESS SPECIFIED)		DIMENSION STYLE IN/MM		SCALE	DESIGN UNITS INCH	THIRD ANGLE PROJECTION
	▽=0	4 PLACES ± --- ± ---	mm	INCH	DRAWN BY DATE	TITLE	MATERIAL NO.	DOCUMENT NO.
	▽=0	3 PLACES ± --- ± .010			PEREZ/AR 01/29/87			
		2 PLACES ± 0.25 ± .014			CHECKED BY DATE	MOLEX INCORPORATED SD-2578		
	1 PLACE ± 0.36 ± ---			APPROVED BY DATE				
		ANGULAR ±1/2°			LENZ 01/29/87			
	DRAFT WHERE APPLICABLE MUST REMAIN WITHIN DIMENSIONS		SEE CHART		THIS DRAWING CONTAINS INFORMATION THAT IS PROPRIETARY TO MOLEX INCORPORATED AND SHOULD NOT BE USED WITHOUT WRITTEN PERMISSION			

2578-(***)*		2578-B-(***)*		2578-B-2-(***)*							
PART NO.	ENG. NO.	PART NO.	ENG. NO.	PART NO.	ENG. NO.	PART NO.	ENG. NO.	PART NO.	ENG. NO.	PART NO.	ENG. NO.
08-50-0107	2578-(P909)	08-56-0121	2578-B-(501)		2578-B-2(P909)						
08-50-0108	2578-(P909)L	08-56-0122	2578-B-(501)L		2578-B-2(P909)L						
08-50-0111	2578-(109)	08-50-0133 *	2578-B-(P909)		2578-B-2(555)						
08-50-0112	2578-(109)L	08-50-0134 *	2578-B-(P909)L		2578-B-2(555)L						
08-56-0107	2578-(550)	08-65-0116 *	2578-B-(555)		2578-B-2(550)						
08-56-0108	2578-(550)L	08-65-0117 *	2578-B-(555)L		2578-B-2(550)L						
08-55-0105	2578-(555)	08-65-0108	2578-B-(591)								
08-56-0106	2578-(555)L	08-65-0107	2578-B-(591)L								
08-59-0101	2578-(122)	08-60-0003	2578-B-(122)								
	2578-(122)L	08-60-0004	2578-B-(122)L								
1 08-56-0162	2578-(505)	08-65-0110	2578-B-(558)								
1 08-56-0163	2578-(505)L	08-65-0111	2578-B-(558)L								
08-50-0504	2578-(128)	08-58-0125 *	2578-B-(550)								
	2578-(128)L	08-58-0126 *	2578-B-(550)L								
08-56-0161	2578-(503)										
	2578-(503)L										
1 08-50-0061	2578-(224)										
1 08-50-0062	2578-(224)L										
1 08-50-0065	2578-(P224)										
1 08-50-0066	2578-(P224)L										
08-55-0137	2578-(558)A										
	2578-(558)L										
08-50-0018	2578-(102)										
08-50-0019	2578-(102)L										
08-55-0121	2578-(561)										
08-55-0132	2578-(561)L										
08-55-0123	2578-(558)										
	2578-(558)L										
08-65-0109	2578-(555)A										
08-52-0116	2578-(P909)										
08-52-0117	2578-(P9109)L										

CHANGE TO ME10 EC NO: UCP2005-0928 DRW:ADRIANO 2004/11/16 CHK:CSAMEC 2004/11/02 APPR: MARGULLIS 2004/11/02 W	QUALITY SYMBOLS ▽=0 ▽=0	GENERAL TOLERANCES (UNLESS SPECIFIED) <table border="1"> <tr> <th></th> <th>mm</th> <th>INCH</th> </tr> <tr> <td>4 PLACES</td> <td>± .005</td> <td>± .0005</td> </tr> <tr> <td>3 PLACES</td> <td>± .005</td> <td>± .0005</td> </tr> <tr> <td>2 PLACES</td> <td>± .005</td> <td>± .0005</td> </tr> <tr> <td>1 PLACE</td> <td>± .005</td> <td>± .0005</td> </tr> </table>		mm	INCH	4 PLACES	± .005	± .0005	3 PLACES	± .005	± .0005	2 PLACES	± .005	± .0005	1 PLACE	± .005	± .0005	DIMENSION STYLE IN/MM	SCALE INCH	DESIGN UNITS INCH	THIRD ANGLE PROJECTION
		mm	INCH																		
	4 PLACES	± .005	± .0005																		
	3 PLACES	± .005	± .0005																		
2 PLACES	± .005	± .0005																			
1 PLACE	± .005	± .0005																			
DRAWN BY PEREZ/AR	DATE 01/29/87	CHECKED BY PATEL	DATE 01/29/87	APPROVED BY LENZ	DATE 01/29/87	MATERIAL NO. DOCUMENT NO. SD-2578															
DRAFT WHERE APPLICABLE MUST REMAIN WITHIN DIMENSIONS						SIZE D	THIS DRAWING CONTAINS INFORMATION THAT IS PROPRIETARY TO MOLEX INCORPORATED AND SHOULD NOT BE USED WITHOUT WRITTEN PERMISSION														
CRIMP TERMINAL (3,96)/.156 CENTERS 22 TO 26 GA WIRE						MOLEX INCORPORATED	SHEET NO. 2														

3.96mm (.156") Pitch Double-Sided Edge KK[®] Connector Terminals

4366 PC Crimp and Solder Eyelet

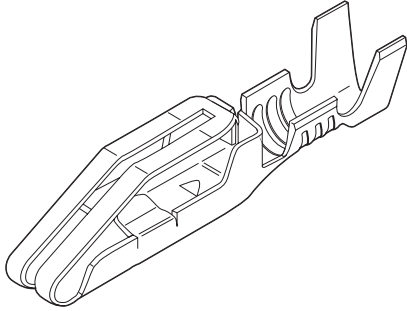

Features and Benefits

- Solder loop version available
- Anti-fishhooking feature prevents terminals from snagging
- Wire barrier prevents stripped wire from entering the contact area
- Coined outside edges prevent excess scoring of the solder pad surfaces
- Patented bifurcated contact area
- Anti-overstress feature

Reference Information

Packaging: Reel or bag
Use With: 4338
Designed In: Inches

Electrical

Voltage: 250V
Current: 5.0A
Contact Resistance: 20 milliohms max.
Dielectric Withstanding Voltage: 1500V
Insulation Resistance: 50,000 Megohms min.

Mechanical

Contact Retention to Housing: 8 lb min.
Wire Pull-Out Force: 20 lb for 18 AWG
(less for smaller wire)

Physical

Contact: Brass
Plating: See Table
Operating Temperature: 0 to +75°C

Order No.		Crimp Wire Size	Maximum Insulation Diameter	Engineering No.	Plating	Lead-free
Reel Form	Bag Form					
08-03-0303	08-03-0304	18-20	2.79 (.110)	4366	Tin	Yes
08-05-0301	08-05-0302			4366	Gold	

3.96mm (.156") Pitch KK[®] Crimp Terminal

2478/2578

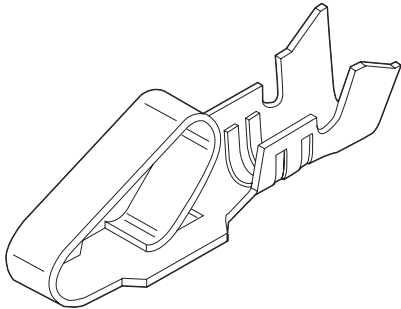

Features and Benefits

- Double cantilever design
- Single beam terminal is available for low insertion force 7821 Series (contact Molex)
- For low-level current and voltage, use Gold plating
- Phosphor Bronze is recommended for rated current
- Complete line of terminal crimping equipment available (see Application Tooling section of this catalog)

Reference Information

Product Specification: PS-08-50
Packaging: Reel or bag
Tooling Information: See crimp tooling section
UL File No.: E29179
CSA File No.: LR19980
Use With: 2139, 3069 and 41695
Designed In: Inches

Electrical

Voltage: 250V AC max.
Current: Max.

AWG	18	20	22	24	26
Phosphor Bronze	7.00A	6.25A	5.50A	5.00A	4.50A
Brass	5.00A	4.75A	4.50A	4.25A	4.00A

Contact Resistance: 6 milliohms max.
Dielectric Withstanding Voltage: 1500V AC
Insulation Resistance: 50K Megohms min.

Mechanical

Contact Insertion Force: 1.8kg (4 lb) max.
Contact Retention to Housing: 3.6kg (8 lb) min.
Wire Pull-Out Force: 20 lb max./18 AWG
Normal Force: 0.75kg (1.65 lb)
Durability: 25 cycles max.

Physical

Contact: Brass or Phosphor Bronze
Plating: See Table
Operating Temperature: Phosphor Bronze—0 to +75°C
Brass—0 to +50°C

Order No.						Wire Size AWG	Insulation OD	Series	Material	Lead-free
Tin Plating		Gold Plating No. 1		Gold Plating No. 2						
Reel	Bag	Reel	Bag	Reel	Bag					
08-52-0071	08-52-0072	08-58-0121	08-58-0122	08-65-0114	08-65-0115	18-20	2.79 (.110)	max. 2478	Phosphor Bronze	Yes
08-50-0105	08-50-0106	08-56-0105	08-56-0106	08-55-0103	08-55-0104	18-20	2.79 (.110)	max. 2478	Brass	
08-50-0133	08-50-0134	08-58-0125	08-58-0126	08-65-0116	08-65-0117	22-26	1.65 (.065)	max. 2578	Phosphor Bronze	
08-50-0107	08-50-0108	08-56-0107	08-56-0108	08-55-0105	08-55-0106	22-26	1.65 (.065)	max. 2578	Brass	

Recommended wire range assumes stranded wire
Plating No. 1: 20µ" min. Gold in contact area with a flash overall
Plating No. 2: 15µ" min. Gold in contact area only