

0467

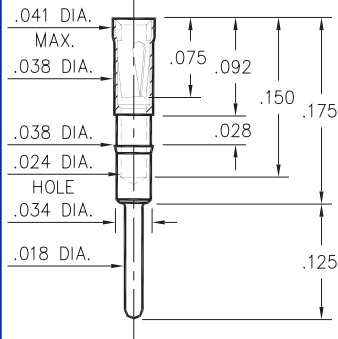

0467-0-15-XX-21-XX-04-0
 Press-fit in .037 mounting hole

0552

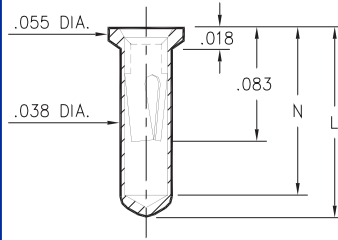

0552-X-15-XX-X1-XX-10-0
 Solder mount in .040 min. mounting hole
 Also available on 16mm wide carrier tape: 1,500 parts per 13" reel.
 Order as: 0552-X-57-XX-X1-XX-10-0

Basic Part Number	Length	Depth
	L	N
0552-1	.136	.120
0552-2	.170	.150

5522

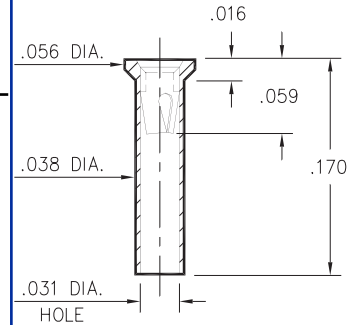

5522-0-15-XX-09-XX-10-0
 Solder mount in .040 min. mounting hole

0569

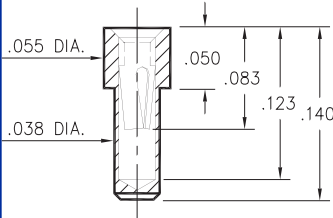

0569-0-15-XX-X1-XX-10-0
 Solder mount in .040 min mounting hole

6023

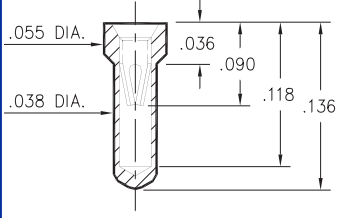

6023-0-15-XX-21-XX-10-0
 Solder mount in .040 min mounting hole

6214

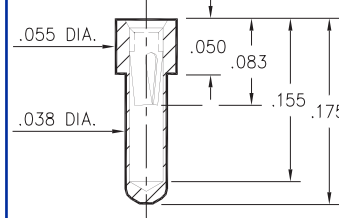

6214-0-15-XX-21-XX-10-0
 Solder mount in .040 min mounting hole

2086

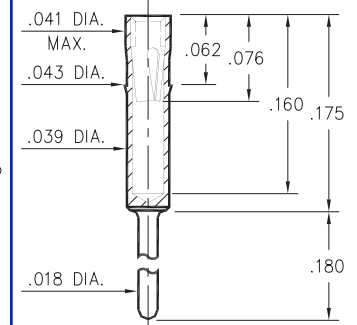

2086-0-15-XX-21-XX-04-0
 Press-fit in .040 mounting hole

0461

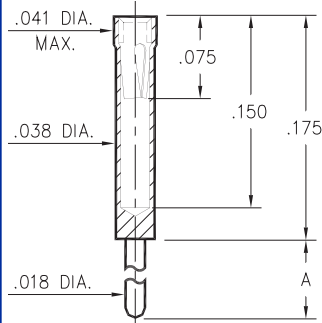

0461-X-15-XX-X1-XX-04-0
 Solder mount in .020 min. mounting hole

Basic Part Number	Length A
0461-0	.400
0461-1	.275
0461-2	.180
0461-3	.125
0461-4	.060
0461-5	.440

8579

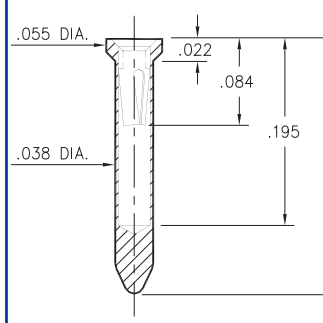

8579-0-15-XX-X1-XX-10-0
 Solder mount in .040 min mounting hole

Basic Part Number	Length L
8579-0	.234
8579-1	.295

SPECIFICATIONS

SHELL MATERIAL:
 Brass Alloy 360, 1/2 Hard

CONTACT MATERIAL:
 Beryllium Copper Alloy 172, HT

DIMENSION IN INCHES
TOLERANCES ON:
 LENGTHS: ±.005
 DIAMETERS: ±.002
 ANGLES: ± 2°

ORDER CODE: XXXX - X - 15 - XX - XX - XX - XX - 0

BASIC PART # →

SPECIFY SHELL FINISH:

- 01 200µ" TIN/LEAD OVER NICKEL
- 80 200µ" TIN OVER NICKEL ◊
- 15 10µ" GOLD OVER NICKEL ◊

SPECIFY CONTACT FINISH:

- 02 100µ" TIN/LEAD OVER NICKEL
- 84 100µ" TIN OVER NICKEL ◊
- 27 30µ" GOLD OVER NICKEL ◊



SELECT CONTACT

#09, #11 or #21 CONTACT (DATA ON PAGE 217)