

### 0326

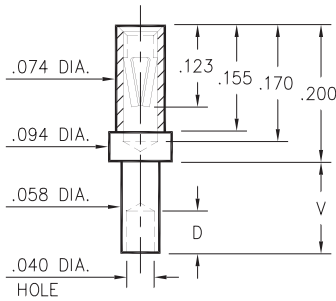

Basic Part Number	Board Thickness	Length V	Depth D
0326-1	.031	.062	.040
0326-2	.062	.094	.062
0326-3	.094	.125	.062
0326-4	.125	.156	.062

**0326-X-19-XX-06-XX-10-0**  
Swage mount in .060 hole

### 5295

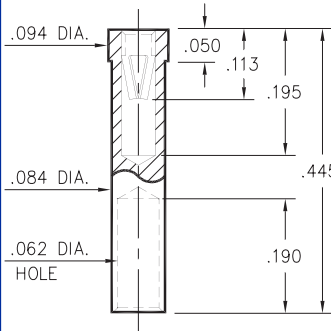

**5295-0-19-XX-06-XX-10-0**  
Solder mount in .086 min. mounting hole

### 0396

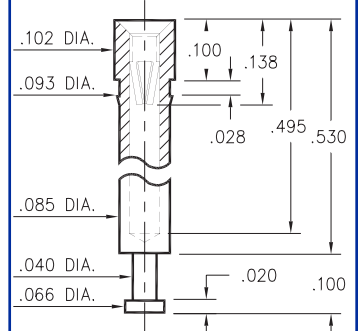

**0396-0-15-XX-06-XX-10-0**  
Press-fit in .090 mounting hole

### 0298

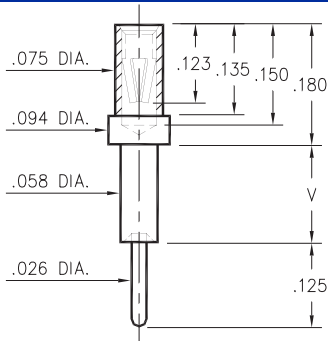

Basic Part Number	Board Thickness	Length V
0298-1	.031	.051
0298-2	.062	.082
0298-3	.094	.113
0298-4	.125	.145

**0298-X-15-XX-06-XX-10-0**  
Swage mount in .060 hole

### 9293



**9293-0-15-XX-06-XX-10-0**  
Hex press-fit in .067 plated thru hole

### 8864

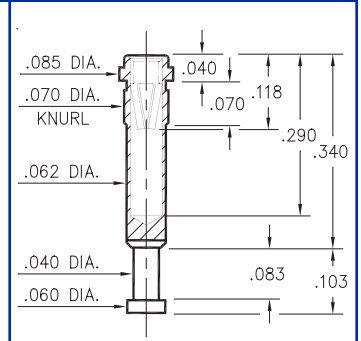

**8864-0-15-XX-06-XX-10-0**  
Press-fit in .067 mounting hole

### 0664

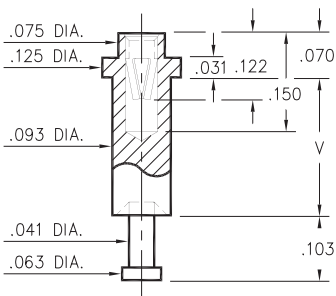

Basic Part Number	Board Thickness	Length V
0664-1	.094	.125
0664-2	.125	.156
0664-3	.188	.219

**0664-X-15-XX-06-XX-10-0**  
Swage mount in .096 hole

#### SPECIFICATIONS

**SHELL MATERIAL:**  
Brass Alloy 360, 1/2 Hard

**CONTACT MATERIAL:**  
Beryllium Copper Alloy 172, HT

**DIMENSION IN INCHES**  
**TOLERANCES ON:**  
LENGTHS: ±.005  
DIAMETERS: ±.002  
ANGLES: ± 2°

**ORDER CODE: XXXX - X - 1X - XX - 06 - XX - 10 - 0**

**BASIC PART #** →

**SPECIFY SHELL FINISH:**

- 01 200µ" TIN/LEAD OVER NICKEL
- 80 200µ" TIN OVER NICKEL ◊
- 15 10µ" GOLD OVER NICKEL ◊

**SPECIFY CONTACT FINISH:**

- 01 200µ" TIN/LEAD OVER NICKEL
- 80 200µ" TIN OVER NICKEL ◊
- 27 30µ" GOLD OVER NICKEL ◊



**CONTACT**

#06 CONTACT (DATA ON PAGE 220)