



Magnecraft
Your Contact for Industrial Relays

relay
solutions

PRODUCTS

COMPANY

SALES CHANNELS

SEARCH

LIBRARY

Features & Benefits:

[Plug-In & Power Relays](#)

[Sockets](#)

[Accessories](#)

[Solid State Relays](#)

[Time Delay & Sensor Relays](#)

[Power Relays](#)

[Latching & Sequencing Relays](#)

[Printed Circuit Board Relays](#)

-- Quick Search

--

Search Distributor Inventory & Buy Online

Locate A Distributor

Cross-Reference A Part Number

Product Search

Select one of the Quick Search categories to conduct a search

[3D Modeling & 2D Drawings](#)

[Order Solutions Guide](#)

[Order Free Samples](#)

[Tell Us How We're Doing](#)

[RoHS Compliant Products](#)

[All Categories](#) > [Relays](#) > [Solid State](#) > Item # 6275AXXSZS-AC90

Request Information

Item # 6275AXXSZS-AC90 Class 6 Solid State Relay / SPST-NO, 75 Amp Rating

[Download PDF](#)

[Email This Page](#)

[Save To Favorites](#)

Class 6 Solid State Relay / SPST-NO, 75 Amp Rating

Class 6 Series:

- Hockey puck design
- Finger-safe cover*
- LED status indicator
- Optically coupled circuitry

*Available for products up to 40 Amps (AC) and 12 Amps (DC).



[larger image](#)

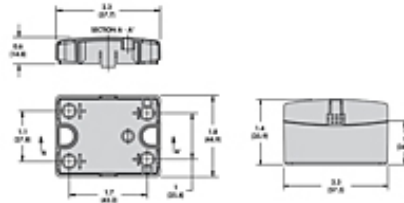

[larger image](#)

MORE IMAGES

- [6 Wiring Diagram](#)
- [6 Part Description](#)
- [Max. Ambient Temperature at 75A](#)

VIEW CAD DRAWING

- [Front View](#)
- [Right Side View](#)
- [3D](#)

DOWNLOADS

[Catalog PDF\(PDF\)](#)

Heat Sink

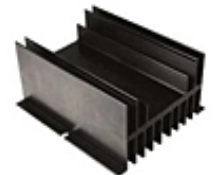

[SSR-HS-1 Heat Sink](#)

[Specifications](#) · [Output Characteristics](#) · [Input Characteristics](#) · [Performance Characteristics](#) · [Environment](#) · [Miscellaneous Characteristics](#) · [Product Certifications](#)

Specifications

Component Type	Solid State
Mounting Type	Panel Mount
Superceding Part No.	W6275ASX-1
Contact Rating	75 A
Contact Configuration	SPST-NO
Output Voltage Range	24 to 280 VAC
Load Type	AC
Switching Type	Zero Cross

Output Characteristics

Switching Device	SCR (2)
Switching Voltage	24 to 280 VAC
Maximum Rate of Rise Off State Voltage [dv/dt]	500 V/us
Incandescent Lamp Ampere Rating [rms]	39 A
Motor Load Rating [rms]	25 A
Min. Load Current to Maintain On	250 mA
Non-Repetitive Surge Current (1 cycle)	1150 A
Max. RMS Overload Current (1 second)	150 A
Max. Off State Leakage Current [rms]	10 mA
Peak Blocking Voltage	600 Vpk
Typical On State Voltage Drop [rms]	1.8 VAC
Max. On State Voltage Drop [rms]	1.8 VAC
Maximum I ² T for Fusing (A ²)	5000

Input Characteristics

Voltage Range	80 to 140 DC 90 to 280 VAC
Must Release Voltage	10 VAC
Nominal Input Impedance	13000 Ohm
Typical Input Current at 5VDC or 240VAC	20 mA

Performance Characteristics

Electrical Life (UL508), Operations at Rated Current (Resistive)	100000
Mechanical Life, Unpowered	10000000
Operating Time (Response Time) - On	8.3 ms
Operating Time (Response Time) - Off	8.3 ms
Rated Insulation Voltage, Input to Output	2500 VAC
Dielectric Strength, Terminals to Chassis	4000 VAC

Environment

Ambient Air Temperature around the Device - Storage	-40 to +100 °C
Ambient Air Temperature around the Device - Operation	-40 to +80 °C
Degree of Protection	IP 20

Miscellaneous Characteristics

Thermal Resistance (Junction to Case)	0.6 °C/W
LED Input	Green
Input Terminal	M3.5
Output Terminal	M6

Product Certifications

Agency Approvals	UL CE CSA
------------------	-----------------

Solid State Relays – Application Data

Definition: A SSR (solid state relay) can perform many tasks that an EMR (electromechanical relay) can perform. The SSR differs in that it has no moving mechanical parts within it. It is essentially an electronic device that relies on the electrical, magnetic and optical properties of semiconductors, and electrical components to achieve its isolation and relay switching function.

Principle of Operation: Solid State Relays are similar to electromechanical relays, in that both use a control circuit and a separate circuit for switching the load. When voltage is applied to the input of the SSR, the relay is energized by a light emitting diode. The light from the diode is beamed into a light sensitive semiconductor which, in the case of zero voltage crossover relays, conditions the control circuit to turn on the output solid state switch at the next zero voltage crossover. In the case of nonzero voltage crossover relays, the output solid state switch is turned on at the precise voltage occurring at the time. Removal of the input power disables the control circuit and the solid state switch is turned off when the load current passes through the zero point of its cycle.

Applications: Since its introduction the SSR, as a technology, has gained acceptance in many areas, which had previously been the sole domain of the EMR or the Contactor. The major growth areas have come from Industrial Process Control applications; particularly heat/cool temperature control, motors, lamps, solenoids, valves, and transformers. The list of applications for the SSR is almost limitless.

The following are typical examples of SSR applications: industrial automation, electronic appliances, industrial appliances, packaging machines, tooling machines, manufacturing equipment, food equipment, security systems, industrial lighting, fire and security systems, dispensing machines, production equipment, on-board power control, traffic control, instrumentation systems, vending machines, test systems, office machines, medical equipment, display lighting, elevator control, metrology equipment, and entertainment lighting.

INDUSTRIAL
AUTOMATION



ALARM
SYSTEMS



ELECTRONIC
APPLIANCES

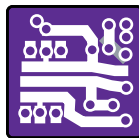

INDUSTRIAL
APPLIANCES



MEDICAL
EQUIPMENT



PACKING
MACHINES



TOOLING
MACHINES



Advantages: When used correctly in the intended application, the SSR provides many of the characteristics that are often difficult to find in the EMR; a high degree of reliability, long service life, significantly reduced electromagnetic interference, fast response and high vibration resistance are significant benefits of the SSR. The SSR has no moving parts to wear out or arcing contacts to deteriorate, which are often the primary cause of failure with an EMR.

- Long life (reliability) > 10⁹ operations
- Zero voltage turn on, low EMI / RFI
- Shock and Vibration resistant
- Random turn-on, proportional control
- No contact bounce
- Arc-less switching
- No acoustical noise
- Microprocessor compatible
- Fast response
- No moving parts

Thermal Considerations: One of the major considerations when using a SSR is properly managing the heat that is generated when switching currents higher than about 5 amps. In this scenario one must mount the base plate of the SSR onto a good heat conductor, typically aluminum; along with utilizing a good thermal transfer medium such as thermal grease or heat transfer pad. Using this technique, the SSR case to heat sink thermal resistance is reduced to a negligible value of 0.1 °C/W.

Advantages of the Class 6 Solid State Relay

The Complete System Solution!



Optional Heat Sink
(SSR-HS-1)
Section 3 p.20



Optional Thermal Pad
(SSR-TP-1)
Section 3 p.21

We at Magnecraft strive to be your one-stop-shop for all of your solid state relay needs. The new line of 6 series solid-state relays give industrial relay users an energy-efficient current switching alternative. Depending on the application, these solid-state relays offer a number of advantages over electromechanical relays, including longer life cycles, less energy consumption and reduced maintenance costs. This is why great care and attention was given when developing the next generation of "Hockey Puck" style SSRs. These new SSRs will be finger-safe, fit a pre-cut heat transfer thermal pad (sold separately) and have the ability to be mounted onto a factory tested pre-drilled and tapped heat sink (sold separately).

Magnecraft's expertise in both SSR design and thermal management enables us to provide customers with a solution to their solid state relay requirements. This solution comes ready-to-use, virtually eliminating in-house assembly and complex heat sink calculations. Furthermore, each SSR, thermal pad (sold separately) and heat sink assembly (sold separately) utilizes the reliability and technology only available in our 6 series solid state relays. These features, coupled with Magnecraft's superior customer service and engineering support team, provide our customers with a level of convenience not easily found in the market today!



Evolu

Legacy

The Class 6 is also available with Blade Terminals.



The new finger-safe Class 6* "Hockey Puck" Style Solid State Relay (SSR) expands and enhances the current Magnecraft Solid State Relay product line.

This product features a finger-safe cover and LED Status Indicator. The optically coupled circuitry isolates the input from the output to give pure solid state performance. This product carries with it agency certifications from UL, CSA, and CE.

*Available for products up to 40 Amps (AC Load) and 12 Amps (DC Load).

Finger Safe
Protects Operators from live circuits.

Input Indication
Green LED.

Optically Coupled Circuit
NO Interference between separate circuits.

Solid State Circuitry
No Moving Parts Involved.

Internal Snubber
Protects from Transients.

Panel Mounting

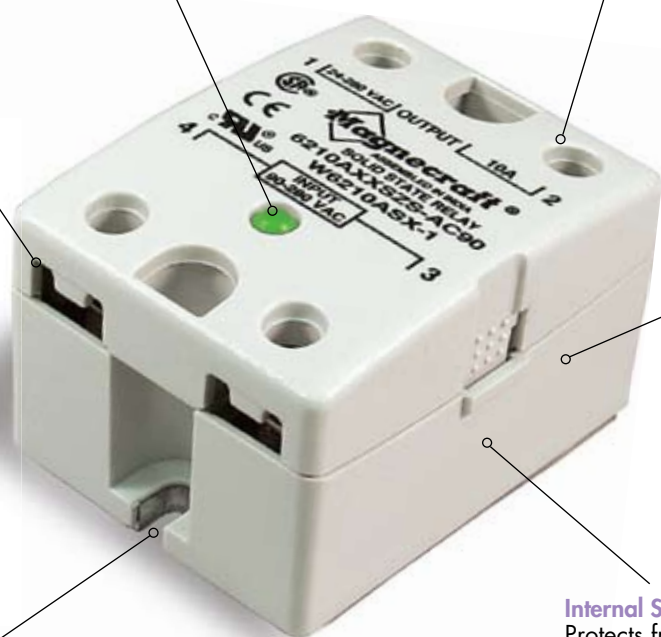

New

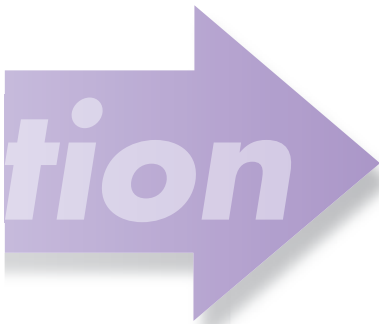



**Thermal Pad
(SSR-TP-1)**
Section 3 p.21



**Blade Terminals
DPST-NO**



**Heat Sink
(SSR-HS-1)**
Section 3 p.20

6225AXXSZS-AC90	6250AXXSZS-AC90	6275AXXSZS-AC90	6210AXXSZS-DC3	6225AXXSZS-DC3
6225ASX-1	6250ASX-1	6275ASX-1	6210DSX-1	6225DSX-1
SPST-NO	SPST-NO	SPST-NO	SPST-NO	SPST-NO
SCR (2)	SCR (2)	SCR (2)	SCR (2)	SCR (2)
25	50	75	10	25
24...280 AC	24...280 AC	24...280 AC	24...280 AC	24...280 AC
Zero Cross	Zero Cross	Zero Cross	Zero Cross	Zero Cross
500	500	500	200	500
16	39	39	8	16
8	14	25	4.5	8
120	250	250	50	120
250	520	1150	83	250
40	100	150	24	40
8	10	10	10	10
600	600	600	600	600
1.6 AC	1.1 AC	1.8 AC	1.6 AC	1.6 AC
1.6 AC	1.8 AC	1.8 AC	1.6 AC	1.6 AC
312	1250	5000	83	250
90...280 AC/80...140 DC	90...280 AC/80...140 DC	90...280 AC/80...140 DC	3...32	3...32
10 AC	10 AC	10 AC	1 DC	1 DC
13K	13K	13K	Current Regulator	Current Regulator
20	20	20	16	16
N/A	N/A	N/A	Yes	Yes
8.3	8.3	8.3	8.3	8.3
8.3	8.3	8.3	8.3	8.3
4000 AC	4000 AC	4000 AC	4000 AC	4000 AC
4000 AC	4000 AC	4000 AC	4000 AC	4000 AC
UR, CSA, CE	UR, CSA, CE	UR, CSA, CE	UR, CSA, CE	UR, CSA, CE
-40...+100	-40...+100	-40...+100	-40...+100	-40...+100
-40...+80	-40...+80	-40...+80	-40...+80	-40...+80
IP 20	IP 20	IP 20	IP 20	IP 20
1.02	0.63	0.6	3.50	1.02
100 (3.5)	135 (4.8)	200 (7.1)	100 (3.5)	100 (3.5)
Green	Green	Green	Green	Green
M3.5	M3.5	M3.5	M3.5	M3.5
M4	M6	M6	M4	M4
1.0	1.0	1.0	1.0	1.0

Class 6 Solid State Relays/SPST-NO, SPST-NC, DPST-NO, 10-125 Amp Rating *continued*



NEW
NEW
NEW
NEW
NEW



Screw Terminals
SPST-NO



Blade Terminals
DPST-NO

*Finger-safe safety cover is available for products up to 40 Amps.

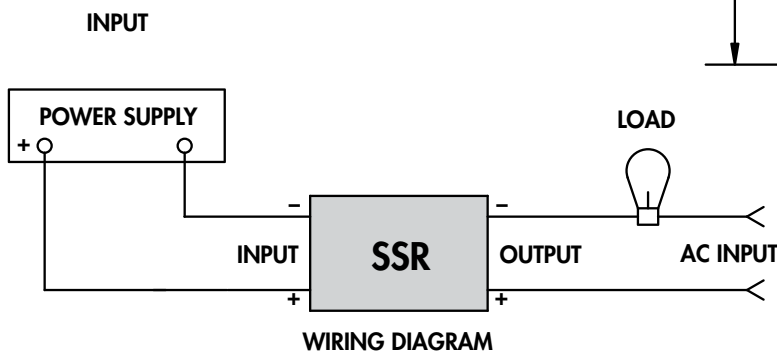
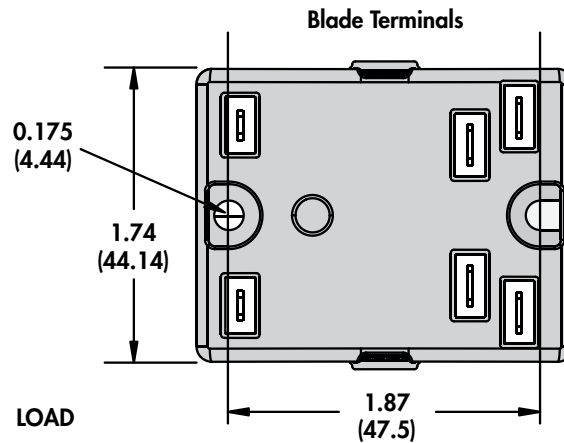
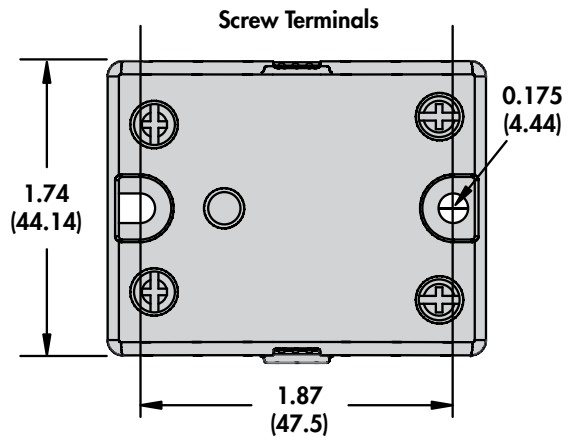
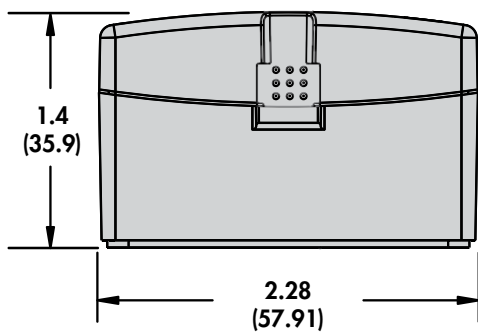
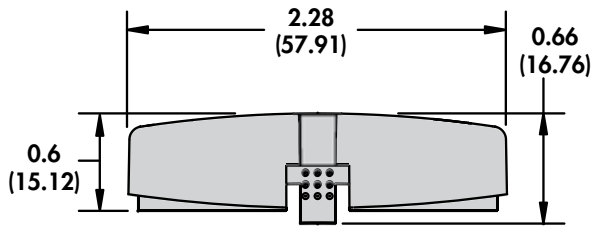

SECTION 4

Class 6 Solid State Relays/SPST-NO, SPST-NC, DPST-NO, 10-125 Amp Rating *continued*



NEW
NEW
NEW
NEW
NEW

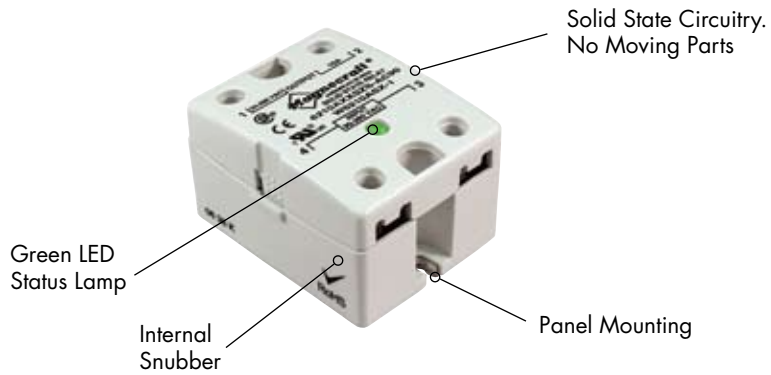

Standard Part Numbers

BOLD-FACED PART NUMBERS ARE NORMALLY STOCKED

AC Operated, DUAL MARKED		Input Voltage Range	Output Voltage Range	Contact Configuration	Switching Type	Rated Current Load (Amps)
New Part #	Supercedes		SCR Output			
6210AXXSZS-AC90	W6210ASX-1	90...280 VAC	24...280 VAC	SPST-NO	Zero Cross	10
6225AXXSZS-AC90	W6225ASX-1	90...280 VAC	24...280 VAC	SPST-NO	Zero Cross	25
6240AXXSZS-AC90	W6240ASX-1	90...280 VAC	24...280 VAC	SPST-NO	Zero Cross	40
6250AXXSZS-AC90**	W6250ASX-1	90...280 VAC	24...280 VAC	SPST-NO	Zero Cross	50
6275AXXSZS-AC90**	W6275ASX-1	90...280 VAC	24...280 VAC	SPST-NO	Zero Cross	75
6410AXXSZS-AC90	W6410ASX-1	90...280 VAC	48...480 VAC	SPST-NO	Zero Cross	10
6425AXXSZS-AC90	W6425ASX-1	90...280 VAC	48...480 VAC	SPST-NO	Zero Cross	25
6440AXXSZS-AC90	W6440ASX-1	90...280 VAC	48...480 VAC	SPST-NO	Zero Cross	40
6450AXXSZS-AC90**	W6450ASX-1	90...280 VAC	48...480 VAC	SPST-NO	Zero Cross	50
6475AXXSZS-AC90**	W6475ASX-1	90...280 VAC	48...480 VAC	SPST-NO	Zero Cross	75
6690AXXSZS-AC90**	W6690ASX-1	90...280 VAC	48...600 VAC	SPST-NO	Zero Cross	90
66125AXXSZS-AC90**	W66125ASX-1	90...280 VAC	48...600 VAC	SPST-NO	Zero Cross	125
DC Operated, DUAL MARKED						
New Part #	Supercedes					
6210AXXSZS-DC3	W6210DSX-1	3...32 VDC	24...280 VAC	SPST-NO	Zero Cross	10
6225AXXSZS-DC3	W6225DSX-1	3...32 VDC	24...280 VAC	SPST-NO	Zero Cross	25
6240AXXSZS-DC3	W6240DSX-1	3...32 VDC	24...280 VAC	SPST-NO	Zero Cross	40
6250AXXSZS-DC3**	W6250DSX-1	3...32 VDC	24...280 VAC	SPST-NO	Zero Cross	50
6275AXXSZS-DC3**	W6275DSX-1	3...32 VDC	24...280 VAC	SPST-NO	Zero Cross	75
6410AXXSZS-DC3	W6410DSX-1	3...32 VDC	48...480 VAC	SPST-NO	Zero Cross	10
6425AXXSZS-DC3	W6425DSX-1	3...32 VDC	48...480 VAC	SPST-NO	Zero Cross	25
6440AXXSZS-DC3	W6440DSX-1	3...32 VDC	48...480 VAC	SPST-NO	Zero Cross	40
6450AXXSZS-DC3**	W6450DSX-1	3...32 VDC	48...480 VAC	SPST-NO	Zero Cross	50
6475AXXSZS-DC3**	W6475DSX-1	3...32 VDC	48...480 VAC	SPST-NO	Zero Cross	75
6690AXXSZS-DC3**	W6690DSX-1	3...32 VDC	48...600 VAC	SPST-NO	Zero Cross	90
66125AXXSZS-DC3**	W66125DSX-1	3...32 VDC	48...600 VAC	SPST-NO	Zero Cross	125
DC Operated, DUAL MARKED						
New Part #	Supercedes		TRIAC Output			
6210AXXTZS-DC3	W6210DTX-1	3...32 VDC	24...280 VAC	SPST-NO	Zero Cross	10
6225AXXTZS-DC3	W6225DTX-1	3...32 VDC	24...280 VAC	SPST-NO	Zero Cross	25
6240AXXTZS-DC3	W6240DTX-1	3...32 VDC	24...280 VAC	SPST-NO	Zero Cross	40
6210BXXTZB-DC3	W6210DTX-3	3...32 VDC	24...280 VAC	DPST-NO	Zero Cross	10
6210XXATRS-DC3	W6210DTX-4	3...32 VDC	24...280 VAC	SPST-NC	Random	10
6225XXATRS-DC3	W6225DTX-4	3...32 VDC	24...280 VAC	SPST-NC	Random	25
6240XXATRS-DC3	W6240DTX-4	3...32 VDC	24...280 VAC	SPST-NC	Random	40
6410AXXTZS-DC3	W6410DTX-1	3...32 VDC	48...480 VAC	SPST-NO	Zero Cross	10
6425AXXTZS-DC3	W6425DTX-1	3...32 VDC	48...480 VAC	SPST-NO	Zero Cross	25
6440AXXTZS-DC3	W6440DTX-1	3...32 VDC	48...480 VAC	SPST-NO	Zero Cross	40
DC Operated, DUAL MARKED						
New Part #	Supercedes		MOSFET Output			
6312AXXMDS-DC3	W6212DDX-1	3...32 VDC	3...200 VDC	SPST-NO	Random	12
6325AXXMDS-DC3**	W6225DDX-1	3...32 VDC	3...200 VDC	SPST-NO	Random	25
6340AXXMDS-DC3**	W6240DDX-1	3...32 VDC	3...200 VDC	SPST-NO	Random	40

**Only Legacy (superceding) part is currently available.

SECTION 4