

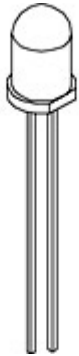

We Tame Photons to Work for You!



Products > LEDs > Thru-Hole > Round > 5mm > Standard > High Intensity



Features / Options

- ▶ State-of-the-Art, High Brightness Chip Technology
- ▶ Choice of Colors and Lens Finishes
- ▶ Lead Frame / Lens Casting Reliability
- ▶ Easy-to-Solder Leads, Tin Finish
- ▶ Available Bulk or on Tape and Reel
- ▶ Lead Trimming and Forming Available
- ▶ Custom Shapes, Easily Tooled, Low Minimum

Applications / Uses

- ▶ Board or Panel Indication or Illumination
- ▶ Annunciator and Control Panels
- ▶ Telecom Switches and Central Station Equipment
- ▶ Large Panel Indicators

Part Number:	Brightness	Dice Material	Emitted Color	Peak Wavelength	Epoxy Lens	Operating Typ Vf (V)	Intensity Typ, mcd @ 20 mA	View Angle 2x Theta	
SSL-LX5093PC	HIGH	InGaN	Pink	-	Clear	3.5	2200	20	—
SSL-LX5093PGD	STANDARD	GaP	Green	555	Diffused	2.1	30	60	—
SSL-LX5093PGT	STANDARD	GaP	Green	555	Color Tinted	2.0	50	30	—
SSL-LX5093SIC	HIGH	AllnGaP	Red	636	Clear	2.0	1800	30	—
SSL-LX5093SID	HIGH	AllnGaP	Red	636	Diffused	2.0	700	60	—
SSL-LX5093SOC	HIGH	AllnGaP	Orange	610	Clear	2.0	2500	30	—
SSL-LX5093SOD	HIGH	AllnGaP	Orange	610	Diffused	2.0	850	60	—
SSL-LX5093SRC/DU	STANDARD	GaAlAs	Red	660	Clear	1.7	1300	30	—
SSL-LX5093SRC/DV	STANDARD	GaAlAs	Red	660	Clear	1.7	1600	30	—
SSL-LX5093SRC/DW	STANDARD	GaAlAs	Red	660	Clear	1.7	2000	30	—

SSL-LX5093SRC/E		STANDARD	GaAlAs	Red	660	Clear	1.7	3500	30		—
SSL-LX5093SUGC		HIGH	AlInGaP	Green	574	Clear	2.2	1000	30		—
SSL-LX5093SUGD		HIGH	AlInGaP	Green	574	Diffused	2.2	170	60		—
SSL-LX5093SYC		HIGH	AlInGaP	Yellow	590	Clear	2.0	1000	30		—
SSL-LX5093SYD		HIGH	AlInGaP	Yellow	590	Diffused	2.0	300	60		—
SSL-LX5093TC		HIGH	InGaN	Turquoise	-	Clear	3.5	2200	20		—
SSL-LX5093UEGC		HIGH	InGaN	Green	505	Clear	3.5	1500	30		—
SSL-LX5093UPGC/C		HIGH	InGaN	Green	525	Clear	4.0	4500	20		—
SSL-LX5093UPGC/D		HIGH	InGaN	Green	525	Clear	3.7	14000	20		—
SSL-LX5093UPGD/D		HIGH	InGaN	Green	525	Diffused	3.5	2800	60		—
SSL-LX5093USBC		HIGH	InGaN	Blue	470	Clear	3.5	1000	30		—
SSL-LX5093USBD		HIGH	InGaN	Blue	470	Diffused	3.5	300	60		—
SSL-LX5093UWC/A		HIGH	InGaN	White	-	Clear	3.5	900	20		—
SSL-LX5093UWC/G		HIGH	InGaN	White	-	Clear	3.5	11000	20		—
SSL-LX5093UWW		HIGH	InGaN	White	-	Diffused	3.5	800	20		—
SSL-LX5093VC		HIGH	InGaN	Purple	-	Clear	3.5	2200	20		—

UNCONTROLLED DOCUMENT

CAUTION: STATIC SENSITIVE DEVICE
FOLLOW PROPER E.S.D. HANDLING PROCEDURES
WHEN WORKING WITH THIS PART.

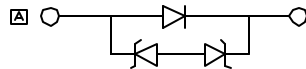
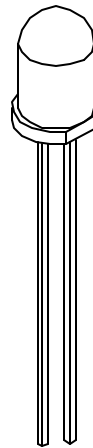
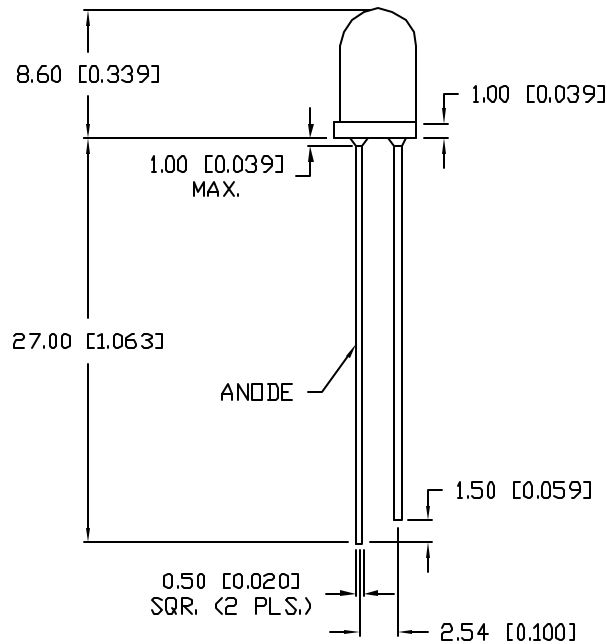
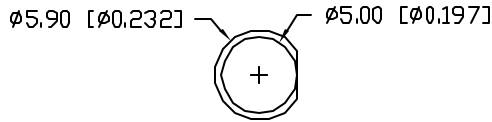

*UNLESS OTHERWISE SPECIFIED TOLERANCES PER DECIMAL PRECISION ARE: X=±1 (±0.039), X.X=±0.5 (±0.020), X.XX=±0.25 (±0.010), X.XXX=±0.127 (±0.005). LEAD SIZE=±0.05 (±0.002), LEAD LENGTH=±0.75 (±0.030), MIN=+0.00 -0.00, MAX.=+0.00 -0.00

PART NUMBER		REV.
SSL-LX5093UWW		B
REV.	E.C.N. NUMBER AND REVISION COMMENTS	DATE
A	E.C.N. #11283.	1.6.06
B	E.C.N. #11148	10.27.06

ELECTRO-OPTICAL CHARACTERISTICS T_A=25°C

PARAMETER	SYMBOL	MIN	TYP	MAX	UNITS	TEST COND
PEAK WAVELENGTH			550 (WHITE)		nm	
FORWARD VOLTAGE	V _f		3.6	4.0	V	I _f =20mA
REVERSE VOLTAGE	V _r	5			V	I _r =10µA
AXIAL INTENSITY(*1)	I _v		680		mcd	I _f =20mA
CHROMATICITY	X		0.29			I _f =10mA
COORDINATES(*2)	Y		0.30			
VIEWING ANGLE			34		2x theta	
EMITTED COLOR:	WHITE					
EPOXY LENS FINISH:	MILKY WHITE DIFFUSED					

*1. AXIAL INTENSITY TESTING CONDITION: 550nm WAVELENGTH.
*2. THE ICI STANDARD COLORIMETRIC SYSTEM.

LIMITS OF SAFE OPERATION AT 25°C

PARAMETER	SYMBOL	MAX	UNITS
PULSE FORWARD CURRENT	I _p	100*	mA
STEADY CURRENT	I _F	30	mA
POWER DISSIPATION	P _D	120	mW
OPERATING TEMP.	T _{OPR}	-30 TO +80	°C
STORAGE TEMP.	T _{STG}	-40 TO +100	°C
SOLDERING TEMP.		+260	°C
2.0mm FROM BODY			3 SEC. MAX

*DUTY 1/10 PULSE WIDTH 10ms



UNCONTROLLED DOCUMENT

REV. B	PART NUMBER SSL-LX5093UWW	CONFIDENTIAL INFORMATION THE INFORMATION CONTAINED IN THIS DOCUMENT IS THE PROPERTY OF LUMEX INC. EXCEPT AS SPECIFICALLY AUTHORIZED IN WRITING BY LUMEX INC, THE HOLDER OF THIS DOCUMENT SHALL KEEP ALL INFORMATION CONTAINED HEREIN CONFIDENTIAL AND SHALL PROTECT SAME IN WHOLE OR IN PART FROM DISCLOSURE AND DISSEMINATION TO ALL THIRD PARTIES.	LUMEX We create - broad-based value for you
T-5mm (T-1) ULTRA WHITE LED, MILKY WHITE DIFFUSED LENS.		RELIABILITY NOTE OUR MANY YEARS OF EXPERIENCE DATA ACCUMULATION INDICATE THAT SOLDER HEAT IS A MAJOR CAUSE OF EARLY AND FUTURE FAILURE. PLEASE PAY ATTENTION TO YOUR SOLDERING PROCESS.	DRAWN BY: JC CHECKED BY: APPROVED BY: DATE: 10.27.06 PAGE: 1 OF 1 SCALE: N/A