

Style	Surface Mount Fuse	Surface Mount Fuse	Surface Mount Fuse	Surface Mount Fuse
Dimensions	7.4 x 3.1 mm	12 x 5.2 mm	11 x 4.6 mm	11 x 4.6 mm
Product picture				
Type	OMT 125	OMZ 125	OMF 250	OMT
Rated Voltage	125 VAC/DC	125 VAC/DC	250 VAC/DC	125 - 250 VAC
Rated Current	0.25 - 5 A	0.25 - 5 A	0.25 - 4 A	0.75 - 5 A
Breaking Capacity	100 A	100 A	100 A	50 A - 100 A
Comment				
Characteristic	Time-Lag T	Time-Lag T	Quick-Acting F	Time-Lag T
Approvals	CCC	CCC	CCC	CCC
Catalogue page	xxx	xxx	xxx	xxx

Style	Surface Mount Fuse	Surface Mount Fuse	Surface Mount Fuse	Subminiature Fuse
Dimensions	5 x 20 mm	5 x 20 mm	5 x 20 mm	6.4 x 6.4 mm
Product picture				
Type	SMD-FST	SMD-SPT	SMD-FTT	MSF 125
Rated Voltage	250 VAC	250 VAC	250 VAC	125 VAC/DC
Rated Current	0.05 - 20 A	1 - 16 A	0.16 - 4 A	0.1 - 5 A
Breaking Capacity	35 A - 125 A	500 A - 1500 A	35 A	300 A
Comment				
Characteristic	Time-Lag T	Time-Lag T	Super-Time-Lag TT	Quick-Acting F
Approvals	CCC	CCC	CCC	CCC
Catalogue page	xxx	xxx	see WEB	xxx

Style	Subminiature Fuse	Subminiature Fuse	Subminiature Fuse	Subminiature Fuse
Dimensions	8.5 x 8.5 mm	8.5 x 8.5 mm	8.5 x 8.5 mm	8.5 x 8.5 mm
Product picture				
Type	MSF 250	MST 250	MSTU 250	MXT 250
Rated Voltage	250 VAC/DC	250/125 VAC/DC	250 VAC	250 VAC
Rated Current	0.04 - 5 A	0.05 - 6.3 A	0.063 - 10 A	0.8 - 10 A
Breaking Capacity	35 A	35 A - 63 A	50 A	100 A
Comment	Fuse Kit available	Fuse Kit available		
Characteristic	Quick-Acting F	Time-Lag T	Time-Lag T	Time-Lag T
Approvals	CCC	CCC	CCC	CCC
Catalogue page	xxx	xxx	xxx	xxx

MSF 250

IEC 60127-3 · 250 VAC/DC · Quick-Acting F

**Description**

- Directly solderable on printed circuit boards
- Low Breaking Capacity

Standards

- IEC 60127-3/3
- UL 248-14
- CSA C22.2 no. 248.14

Approvals

- VDE License Number: 101035
- UL File Number: E41599

Technical Data

Rated Voltage	250 VAC/DC
Rated Current	0.04 - 5 A
Breaking Capacity	35 A
Characteristic	Quick-Acting F
Mounting	PCB, THT
Admissible Ambient Air Temp.	-40 °C to 85 °C
Climatic Category	40/085/21 acc. to IEC 60068-1
Material: Housing	Thermoplastic, UL 94V-0
Material: Terminals	Tin-Plated Copper
Unit Weight	0.5 g
Stock Conditions	0 °C to 60 °C, max. 70% r.h.
Product Marking	□ Type, Current Rating, Voltage Rating, Characteristic, Approvals

Soldering Methods	Wave, Iron
Solderability	235 °C / 2 sec acc. to IEC 60068-2-20, Test Ta, method 1
Resistance to Soldering Heat	260 °C / 5 sec acc. to IEC 60068-2-20, Test Tb, method 1A
Resistance to Vibration	acc. to IEC 60068-2-6, test Fc
Current Carrying Capacity	acc. to EIA/IS-722, Test 4.3.3
Life Test	MIL-STD-202, Method 108A (1000h @ 0.42*In @ 70°C)
Load Humidity Test	MIL-STD-202, Method 103B (1000h @ 0.1*In @ 0.85 r.H. @ 85°C)
Moisture Resistance Test	MIL-STD-202, Method 106E (50 cycles in a temp./mister chamber)
Terminal Strength	MIL-STD-202, Method 211A (Deflection of board 1 mm for 1 minute)
Thermal Shock	MIL-STD-202, Method 107D (200 air-to-air cycles from -55 to +125°C)
Case Resistance	acc. to EIA/IS-722, Test 4.7 >100 MΩ (between leads and body)
Mechanical Shock	MIL-STD-202, Method 213B (Shock 50gn, half sine wave, 11 ms)
Resistance to Solvents	MIL-STD-202, Method 215A
Flammability	min. UL 94V-1 (acc. to EIA/IS-722, Test 4.12)

MSF 250

Dimensions

Length  8.5 mm

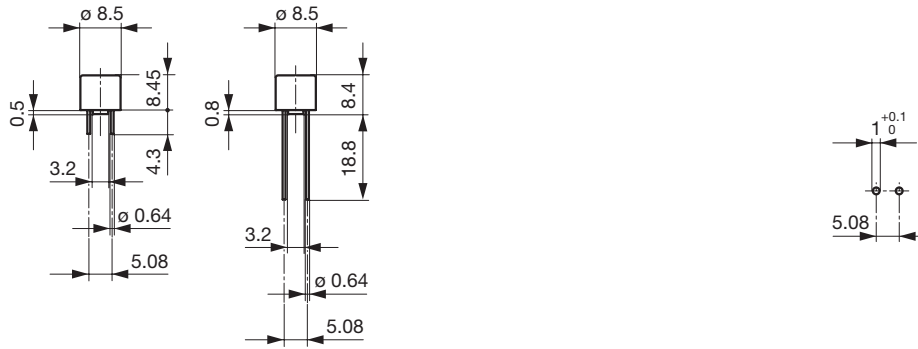

Drilling Diagram

Pre-Arcing Time

Rated Current I_n	1.5 x I_n min.	2.1 x I_n max.	2.75 x I_n min.	2.75 x I_n max.	4.0 x I_n min.	4.0 x I_n max.	10.0 x I_n max.
0.04 A - 5 A	60 min	30 min	10 ms	3 s	3 ms	300 ms	20 ms

MSF 250





Variants

S = Short Terminals
L = Long Terminals
T = Taped and Reeled

Order Number	S	L	T	Rated Current [A]	Rated Voltage [V]	Breaking Capacity	Voltage Drop 1.0 In max [mV]	Voltage Drop 1.0 In typ [mV]	Power Dissipation 1.5 In max [mW]	Melting I ² t 10.0 In typ [A ² s]			
0034.6000	●			0.04	250	1)		400		0.00016	●		●
0034.6001	●			0.05	250	1)	850	460	110	0.0004	●	●	●
0034.6002	●			0.063	250	1)	750	330	120	0.001	●	●	●
0034.6003	●			0.08	250	1)	650	280	140	0.001	●	●	●
0034.6004	●			0.1	250	1)	600	300	160	0.002	●	●	●
0034.6005	●			0.125	250	1)	550	210	180	0.006	●	●	●
0034.6006	●			0.16	250	1)	500	460	210	0.014	●	●	●
0034.6007	●			0.2	250	1)	480	470	250	0.024	●	●	●
0034.6008	●			0.25	250	1)	440	360	290	0.058	●	●	●
0034.6009	●			0.315	250	1)	400	345	330	0.104	●	●	●
0034.6010	●			0.4	250	1)	370	80	390	0.044	●	●	
0034.6011	●			0.5	250	1)	350	75	460	0.09	●	●	●
0034.6012	●			0.63	250	1)	320	70	530	0.15	●	●	●
0034.6013	●			0.8	250	1)	300	70	630	0.22	●	●	●
0034.6014	●			1	250	1)	280	70	740	0.33	●	●	●
0034.6015	●			1.25	250	1)	280	65	920	0.68	●	●	●
0034.6016	●			1.6	250	1)	250	70	1000	0.94	●	●	●
0034.6017	●			2	250	1)	240	70	1360	1.3	●	●	●
0034.6018	●			2.5	250	1)	200	65	1310	1.9	●	●	●
0034.6019	●			3.15	250	1)	180	65	1490	5.4	●	●	●
0034.6020	●			4	250	2)	160	60	1680	7.9	●		●
0034.6021	●			5	250	2)	150	60	1970	11.2	●		●
0034.6030	●			0.04	250	1)		400		0.00016	●		●
0034.6031	●			0.05	250	1)	850	460	110	0.0004	●	●	●
0034.6032	●			0.063	250	1)	750	330	120	0.001	●	●	●
0034.6033	●			0.08	250	1)	650	280	140	0.001	●	●	●
0034.6034	●			0.1	250	1)	600	300	160	0.002	●	●	●
0034.6035	●			0.125	250	1)	550	210	180	0.006	●	●	●
0034.6036	●			0.16	250	1)	500	460	210	0.014	●	●	●
0034.6037	●			0.2	250	1)	480	470	250	0.024	●	●	●
0034.6038	●			0.25	250	1)	440	360	290	0.058	●	●	●
0034.6039	●			0.315	250	1)	400	345	330	0.104	●	●	●
0034.6040	●			0.4	250	1)	370	80	390	0.044	●	●	
0034.6041	●			0.5	250	1)	350	75	460	0.09	●	●	●
0034.6042	●			0.63	250	1)	320	70	530	0.15	●	●	●
0034.6043	●			0.8	250	1)	300	70	630	0.22	●	●	●
0034.6044	●			1	250	1)	280	70	740	0.33	●	●	●
0034.6045	●			1.25	250	1)	280	65	920	0.68	●	●	●
0034.6046	●			1.6	250	1)	250	70	1000	0.94	●	●	●
0034.6047	●			2	250	1)	240	70	1360	1.3	●	●	●
0034.6048	●			2.5	250	1)	200	65	1310	1.9	●	●	●
0034.6049	●			3.15	250	1)	180	65	1490	5.4	●	●	●
0034.6050	●			4	250	2)	160	60	1680	7.9	●		●
0034.6051	●			5	250	2)	150	60	1970	11.2	●		●
0034.6060	●			0.04	250	1)		400		0.00016	●		●
0034.6061	●			0.05	250	1)	850	460	110	0.0004	●	●	●
0034.6062	●			0.063	250	1)	750	330	120	0.001	●	●	●
0034.6063	●			0.08	250	1)	650	280	140	0.001	●	●	●
0034.6064	●			0.1	250	1)	600	300	160	0.002	●	●	●

MSF 250

Variants

Order Number	S	L	T	Rated Current [A]	Rated Voltage [V]	Breaking Capacity	Voltage Drop 1.0 In max [mV]	Voltage Drop 1.0 In typ [mV]	Power Dissipation 1.5 In max [mW]	Melting Pt 10.0 In typ [A ² s]				
0034.6065	●			0.125	250	1)	550	210	180	0.006	●	●	●	
0034.6066	●			0.16	250	1)	500	460	210	0.014	●	●	●	
0034.6067	●			0.2	250	1)	480	470	250	0.024	●	●	●	
0034.6068	●			0.25	250	1)	440	360	290	0.058	●	●	●	
0034.6069	●			0.315	250	1)	400	345	330	0.104	●	●	●	
0034.6070	●			0.4	250	1)	370	80	390	0.044	●	●		
0034.6072	●			0.63	250	1)	320	70	530	0.15	●	●	●	
0034.6073	●			0.8	250	1)	300	70	630	0.22	●	●	●	
0034.6074	●			1	250	1)	280	70	740	0.33	●	●	●	
0034.6075	●			1.25	250	1)	280	65	920	0.68	●	●	●	
0034.6076	●			1.6	250	1)	250	70	1000	0.94	●	●	●	
0034.6077	●			2	250	1)	240	70	1360	1.3	●	●	●	
0034.6078	●			2.5	250	1)	200	65	1310	1.9	●	●	●	
0034.6079	●			3.15	250	1)	180	65	1490	5.4	●	●	●	
0034.6080	●			4	250	2)	160	60	1680	7.9		●		●
0034.6081	●			5	250	2)	150	60	1970	11.2		●		●

1) 35 A @ 250 VAC

2) 10 In @ 250 VAC

Packaging Unit

S + L = Plastic Bag (100 pcs.)

T = Taped 36 cm Reel (750 pcs.)

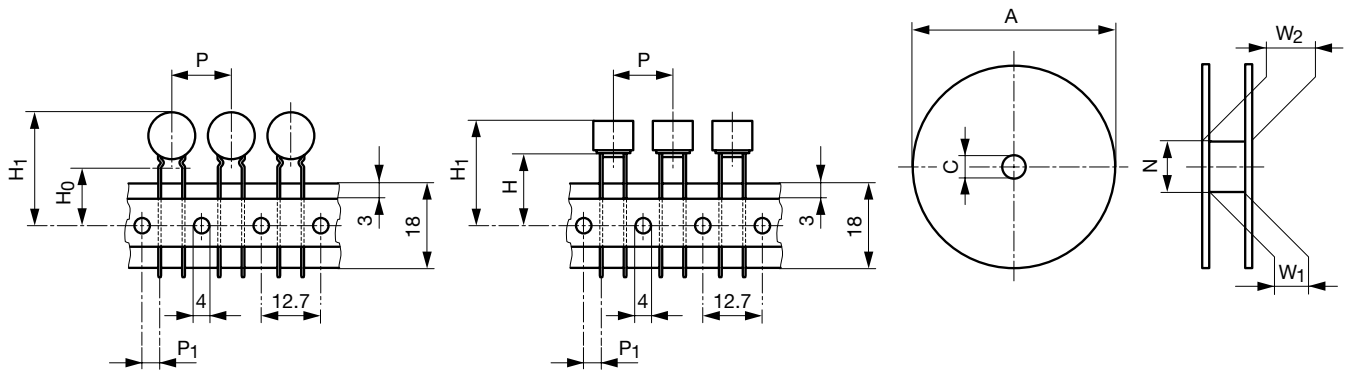

Tape and Reel Dimensions

according to IEC 60286-2

Type mm	P [mm]	P1 [mm]	H1 [mm]	H0 [mm]	H [mm]	N [mm]	W1 [mm]	W2 [mm]	C [mm]	A 750 Pcs.	A 1000 Pcs.	A 1500 Pcs.	A 3000 Pcs.
MSF 125	12.7	5.08	25.8		18	80	40	52	30.5	360 mm			
MSF 250	12.7	3.81	26.45		18	80	40	52	30.5	360 mm			
MST 250	12.7	3.81	26.45		18	80	40	52	30.5	360 mm			
MSTU 250	12.7	3.81	26.45		18	80	40	52	30.5	360 mm			
MXT 250	12.7	3.81	26.45		18	80	40	52	30.5	360 mm			
PFRA.010.2 ... 160.2	12.7	3.81	32.2	16		80							340 mm
PFRA.185.2 ... 400.2	25.4	3.81	38		18.5	80							340 mm
PFRA.110.2 ... 375.2	25.4	3.81	38		18.5	80				340 mm	340 mm		

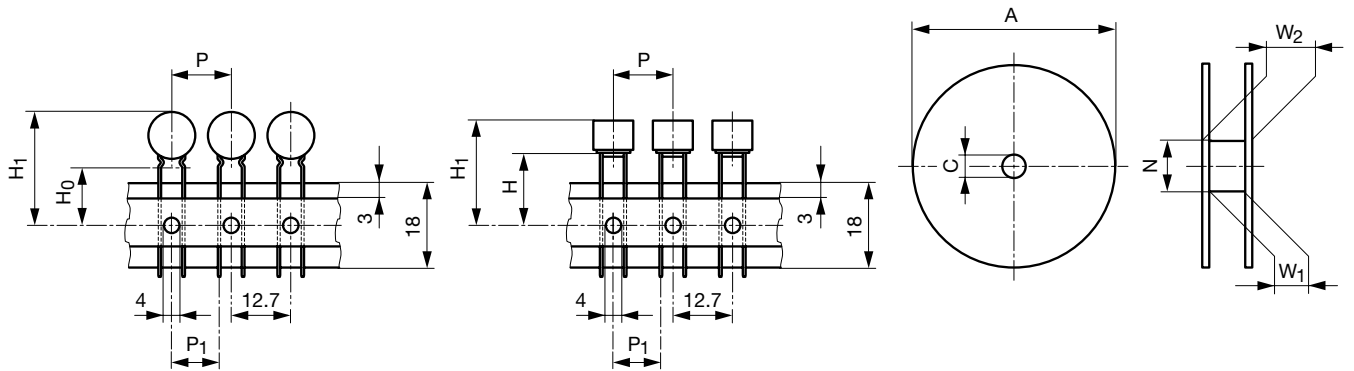

Tape and Reel Dimensions

according to IEC 60286-2

Type	P [mm]	P1 [mm]	H1 [mm]	H0 [mm]	H [mm]	N [mm]	W1 [mm]	W2 [mm]	C [mm]	A 500 Pcs.	A 1000 Pcs.
FRT 250F	12.7	8.95	26		18	80	40	52	30.5	360 mm	360 mm
FRT 250T	12.7	8.95	26		18	80	40	52	30.5	360 mm	360 mm