



Part Number: **0473005**

Technology: **Fuses**

Series: **473**

473 Series - PICO® II Slo-Blo Subminiature Axial Leaded Fuse

- Subminiature time-delay fuse for soldered mounting on printed circuit boards.
- Available on tape and reel for automatic insertion.
- Request bulletin PB-1027 for further information.

Electrical Characteristics

| Property | Value |
|-----------------------------|--------------|
| Amp Rating (A) | 5 |
| Form Factor | PICO® |
| Fuse Class | Supplemental |
| I^2t (A ² Sec) | 54.799999 |
| Opening Characteristic | Slo-Blo® |
| Resistance (Ohms) | 0.0133 |
| Voltage Rating (V) | 125 |

RoHS **473 Series, PICO® II, Slo-Blo® Fuse**



Description

The PICO® II Slo-Blo® Fuse combines time-delay performance characteristics with the proven reliability of a PICO® Fuse.

Features

- Enhanced inrush withstand
- Small size
- Wide range of current ratings (375mA - 7A)
- RoHS compliant
- Wide operating temperature range
- Low temperature de-rating

Applications

- Flat-panel Display TV
- LCD monitor
- Lighting system
- Medical equipment
- Industrial equipment

Agency Approvals

| Agency | Agency File Number | Ampere Range |
|--------|---------------------|--------------|
| | E10480 | 375mA - 7A |
| | LR 29862 | 375mA - 7A |
| | JET 1896-31007-1001 | 1A - 5A |

Electrical Characteristics

| % of Ampere Rating | Opening Time |
|--------------------|--|
| 100% | 4 Hours, Min. |
| 200% | 1 Sec., Min. ; 60 Sec., Max. |
| 300% | 0.2 Sec., Min. ; 3 Sec., Max. |
| 800% | 0.02 Sec., Min. ; 0.1 Sec., Max. |

Electrical Characteristics

| Ampere Rating (A) | Amp Code | Max Voltage Rating (V) | Interrupting Rating | Nominal Cold Resistance (Ohms) | Nominal Melting I ² t (A ² sec) | Nom Voltage Drop (mV) | Agency Approvals | | |
|-------------------|----------|------------------------|-------------------------------|--------------------------------|---|-----------------------|------------------|---|---|
| | | | | | | | | | |
| 0.375 | .375 | 125 | 50 amperes at 125 VDC/ VAC | 1.7400 | 0.085 | 0.840 | X | X | |
| 0.500 | .500 | 125 | | 1.1300 | 0.210 | 0.775 | X | X | |
| 0.750 | .750 | 125 | | 0.4600 | 0.760 | 0.429 | X | X | |
| 1.00 | 001. | 125 | | 0.2670 | 2.010 | 0.353 | X | X | X |
| 1.50 | 01.5 | 125 | | 0.1160 | 3.940 | 0.208 | X | X | X |
| 2.00 | 002. | 125 | | 0.0712 | 7.600 | 0.180 | X | X | X |
| 2.25 | 2.25 | 125 | | 0.0630 | 9.280 | 0.164 | X | X | X |
| 2.50 | 02.5 | 125 | | 0.0520 | 13.00 | 0.153 | X | X | X |
| 3.00 | 003. | 125 | | 0.0380 | 21.00 | 0.140 | X | X | |
| 3.50 | 03.5 | 125 | | 0.0240 | 26.80 | 0.094 | X | X | |
| 4.00 | 004. | 125 | | 0.0194 | 35.00 | 0.086 | X | X | |
| 5.00 | 005. | 125 | | 0.0133 | 54.80 | 0.074 | X | X | |
| 7.00 | 007. | 125 | | 0.0092 | 105.00 | 0.070 | X | X | |

Temperature Derating Curve

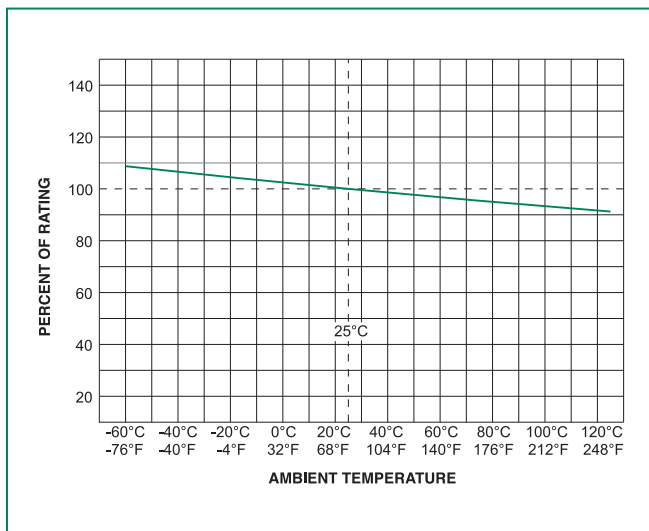

Average Time Current Curves

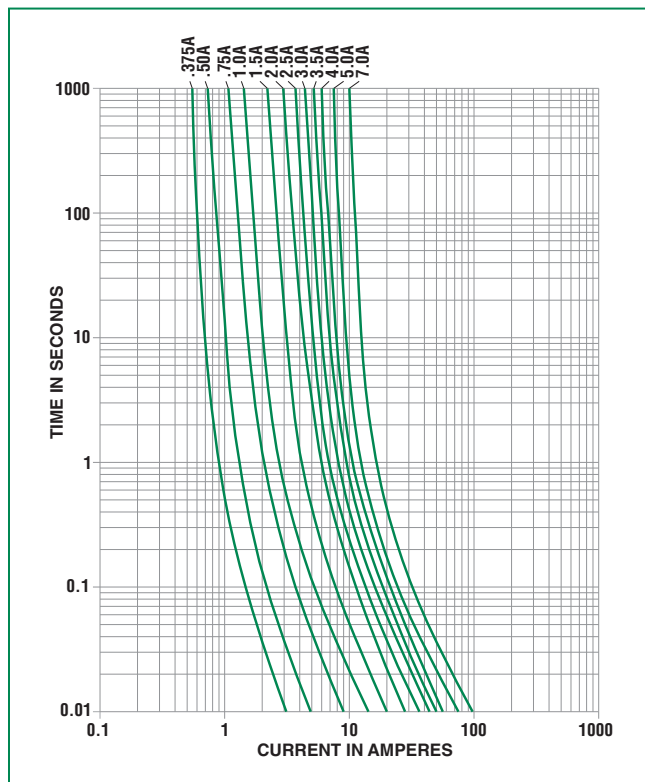

Soldering Parameters

Recommended Process Parameters:

| Wave Parameter | Lead-Free Recommendation |
|--|-----------------------------------|
| Preheat: (Depends on Flux Activation Temperature) | (Typical Industry Recommendation) |
| Temperature Minimum: | 100° C |
| Temperature Maximum: | 150° C |
| Preheat Time: | 60-180 seconds |
| Solder Pot Temperature: | 280° C Maximum |
| Solder Dwell Time: | 2-5 seconds |

Recommended Hand-Solder Parameters:

Solder Iron Temperature: 350° C +/- 5° C
Heating Time: 5 seconds max.

Note: These devices are not recommended for IR or Convection Reflow process.

Product Characteristics

| | |
|----------------------------------|--|
| Materials | Encapsulated, Epoxy-Coated Body; Solder Coated Copper wire leads; RoHS compliant Product: Pure Tin-coated Copper wire leads |
| Solderability | MIL-STD-202, Method 208 |
| Lead Pull Force | MIL-STD-202, Method 211, Test Condition A (will withstand 7 lbs. axial pull test) |
| Operating Temperature | -55°C to +125°C |
| Shock | MIL-STD-202, Method 213, Test Condition I (100 G's peak for 6 milliseconds) |

| | |
|---|--|
| Vibration | MIL-STD-202, Method 201 (10–55 Hz); MIL-STD-202, Method 204, Test Condition C (55–2000 Hz at 10 G's Peak) |
| Salt Spray | MIL-STD-202, Method 101, Test Condition B |
| Insulation Resistance (After Opening): | MIL-STD-202, Method 302, (10,000 ohms minimum at 100 volts) |
| Resistance to Soldering Heat | MIL-STD-202, Method 210, Test Condition C (20 sec at 260°C) |
| Thermal Shock | MIL-STD-202, Method 107, Test Condition B (-65°C to 125°C) |
| Moisture Resistance | MIL-STD-202, Method 106 (90–98% RH), Heat (65°C) |

Dimensions

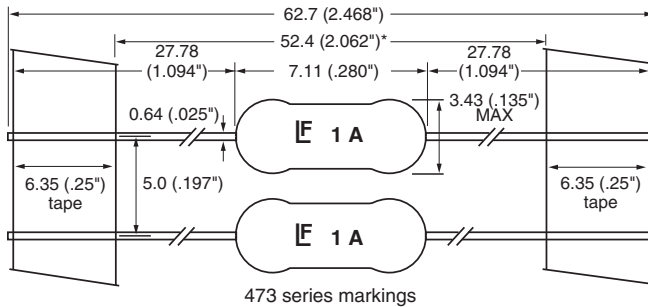

Part Numbering System

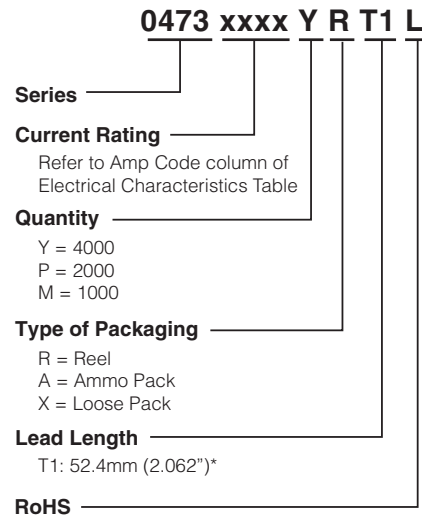

Packaging

| Packaging Option | Packaging Specification | Quantity & Packaging Code |
|------------------------------------|-------------------------|--|
| *T1: 52.4mm (2.062") Tape and Reel | EIA 296 | Please refer to available quantities above in "Part Numbering System" |

Notes: * T1 dimension is defined as the length of the component between the two tapes. The full component length is 62.7mm (2.468").