

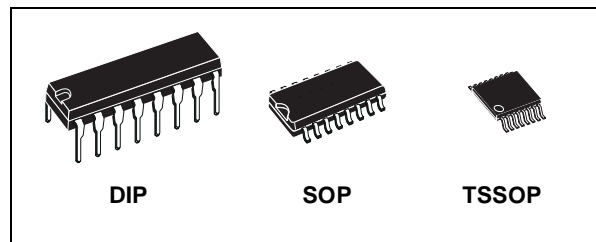

# M74HC161

## SYNCHRONOUS PRESETTABLE 4-BIT COUNTER

- HIGH SPEED :  
 $f_{MAX} = 62 \text{ MHz (TYP.) at } V_{CC} = 6V$
- LOW POWER DISSIPATION:  
 $I_{CC} = 4\mu\text{A (MAX.) at } T_A = 25^\circ\text{C}$
- HIGH NOISE IMMUNITY:  
 $V_{NIH} = V_{NIL} = 28 \% V_{CC} \text{ (MIN.)}$
- SYMMETRICAL OUTPUT IMPEDANCE:  
 $|I_{OH}| = I_{OL} = 4\text{mA (MIN)}$
- BALANCED PROPAGATION DELAYS:  
 $t_{PLH} \cong t_{PHL}$
- WIDE OPERATING VOLTAGE RANGE:  
 $V_{CC} \text{ (OPR)} = 2V \text{ to } 6V$
- PIN AND FUNCTION COMPATIBLE WITH  
 74 SERIES 161



### ORDER CODES

PACKAGE	TUBE	T & R
DIP	M74HC161B1R	
SOP	M74HC161M1R	M74HC161RM13TR
TSSOP		M74HC161TTR

### DESCRIPTION

The M74HC161 is an high speed CMOS SYNCHRONOUS 4-BIT BINARY PRESETTABLE COUNTER fabricated with silicon gate C<sup>2</sup>MOS technology. The CLOCK input is active on the rising edge. Both LOAD and CLEAR inputs are active LOW. Presetting is synchronous on the rising edge of the clock, the function is cleared asynchronously.

Two enable inputs (TE and PE) and CARRY output are provided to enable easy cascading of counters, which facilitates easy implementation of N-bit counters without using external gates. All inputs are equipped with protection circuits against static discharge and transient excess voltage.

### PIN CONNECTION AND IEC LOGIC SYMBOLS

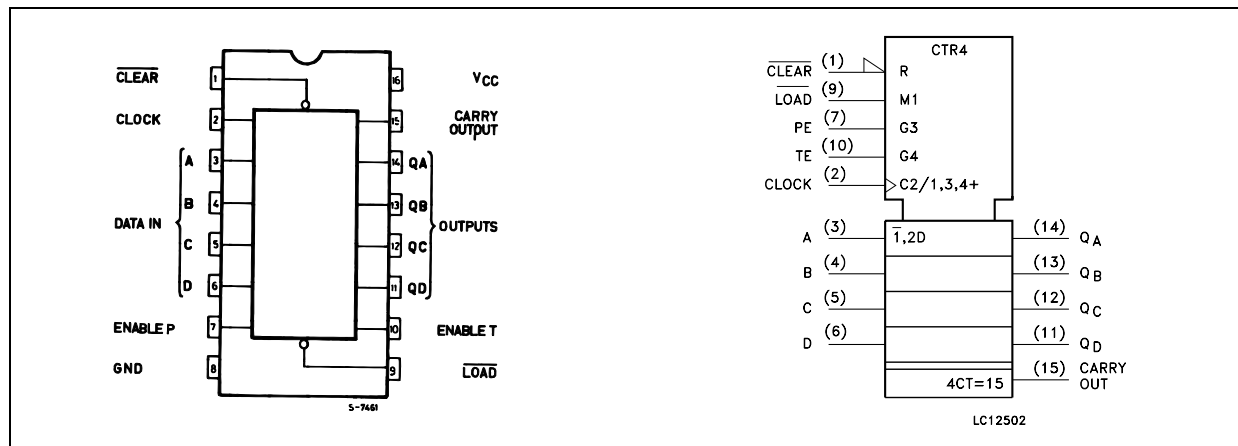

## TIMING CHART

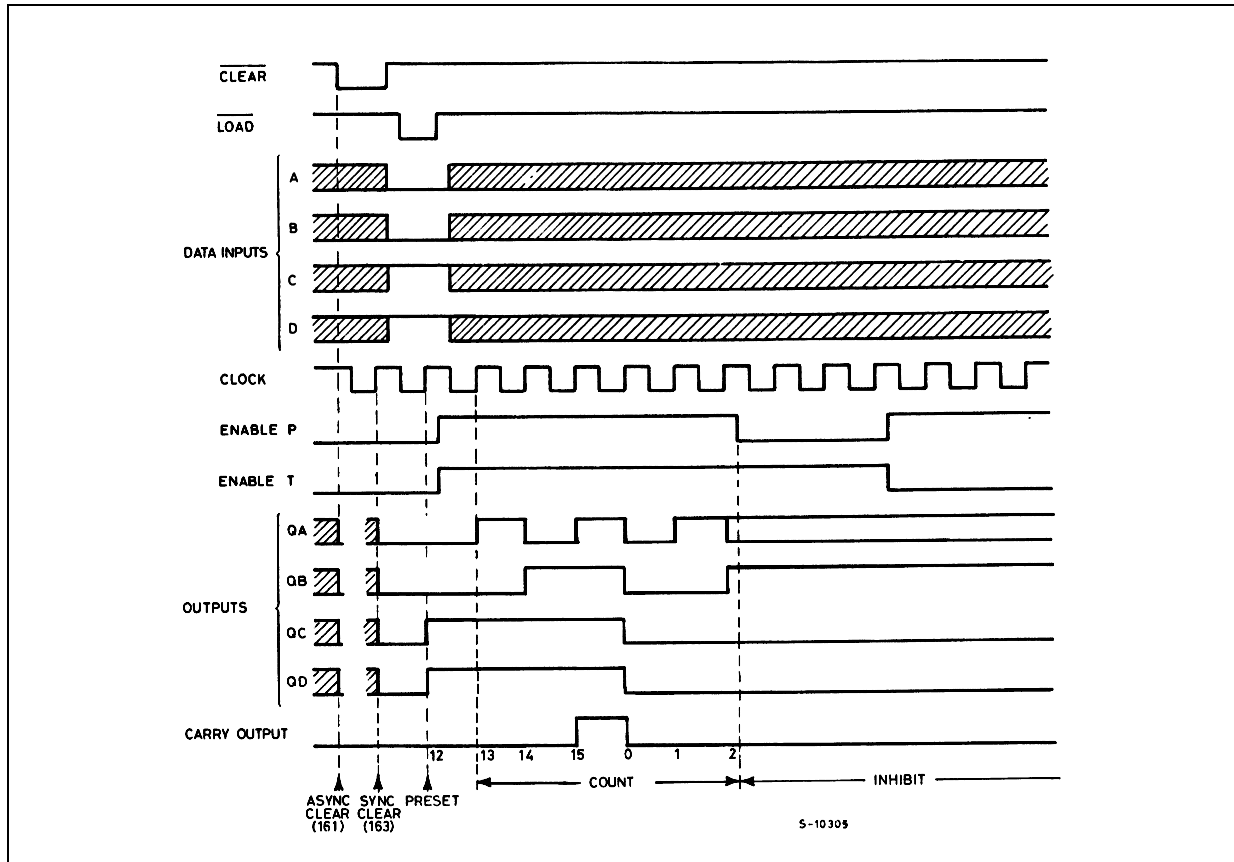

## ABSOLUTE MAXIMUM RATINGS

Symbol	Parameter	Value	Unit
$V_{CC}$	Supply Voltage	-0.5 to +7	V
$V_I$	DC Input Voltage	-0.5 to $V_{CC} + 0.5$	V
$V_O$	DC Output Voltage	-0.5 to $V_{CC} + 0.5$	V
$I_{IK}$	DC Input Diode Current	$\pm 20$	mA
$I_{OK}$	DC Output Diode Current	$\pm 20$	mA
$I_O$	DC Output Current	$\pm 25$	mA
$I_{CC}$ or $I_{GND}$	DC $V_{CC}$ or Ground Current	$\pm 50$	mA
$P_D$	Power Dissipation	500(*)	mW
$T_{stg}$	Storage Temperature	-65 to +150	$^{\circ}C$
$T_L$	Lead Temperature (10 sec)	300	$^{\circ}C$

Absolute Maximum Ratings are those values beyond which damage to the device may occur. Functional operation under these conditions is not implied.

(\*) 500mW at 65  $^{\circ}C$ ; derate to 300mW by 10mW/ $^{\circ}C$  from 65 $^{\circ}C$  to 85 $^{\circ}C$

## RECOMMENDED OPERATING CONDITIONS

Symbol	Parameter	Value	Unit	
$V_{CC}$	Supply Voltage	2 to 6	V	
$V_I$	Input Voltage	0 to $V_{CC}$	V	
$V_O$	Output Voltage	0 to $V_{CC}$	V	
$T_{op}$	Operating Temperature	-55 to 125	°C	
$t_r, t_f$	Input Rise and Fall Time	$V_{CC} = 2.0V$	0 to 1000	ns
		$V_{CC} = 4.5V$	0 to 500	ns
		$V_{CC} = 6.0V$	0 to 400	ns

## DC SPECIFICATIONS

Symbol	Parameter	Test Condition		Value						Unit	
		$V_{CC}$ (V)		$T_A = 25^\circ C$			-40 to 85°C		-55 to 125°C		
				Min.	Typ.	Max.	Min.	Max.	Min.		Max.
$V_{IH}$	High Level Input Voltage	2.0		1.5			1.5		1.5		V
		4.5		3.15			3.15		3.15		
		6.0		4.2			4.2		4.2		
$V_{IL}$	Low Level Input Voltage	2.0				0.5		0.5		0.5	V
		4.5				1.35		1.35		1.35	
		6.0				1.8		1.8		1.8	
$V_{OH}$	High Level Output Voltage	2.0	$I_O = -20 \mu A$	1.9	2.0		1.9		1.9		V
		4.5	$I_O = -20 \mu A$	4.4	4.5		4.4		4.4		
		6.0	$I_O = -20 \mu A$	5.9	6.0		5.9		5.9		
		4.5	$I_O = -4.0 mA$	4.18	4.31		4.13		4.10		
		6.0	$I_O = -5.2 mA$	5.68	5.8		5.63		5.60		
$V_{OL}$	Low Level Output Voltage	2.0	$I_O = 20 \mu A$		0.0	0.1		0.1		0.1	V
		4.5	$I_O = 20 \mu A$		0.0	0.1		0.1		0.1	
		6.0	$I_O = 20 \mu A$		0.0	0.1		0.1		0.1	
		4.5	$I_O = 4.0 mA$		0.17	0.26		0.33		0.40	
		6.0	$I_O = 5.2 mA$		0.18	0.26		0.33		0.40	
$I_I$	Input Leakage Current	6.0	$V_I = V_{CC}$ or GND			$\pm 0.1$		$\pm 1$		$\pm 1$	$\mu A$
$I_{CC}$	Quiescent Supply Current	6.0	$V_I = V_{CC}$ or GND			4		40		80	$\mu A$

AC ELECTRICAL CHARACTERISTICS ( $C_L = 50$  pF, Input  $t_r = t_f = 6$  ns)

Symbol	Parameter	Test Condition		Value						Unit	
		$V_{CC}$ (V)		$T_A = 25^\circ\text{C}$			$-40$ to $85^\circ\text{C}$		$-55$ to $125^\circ\text{C}$		
				Min.	Typ.	Max.	Min.	Max.	Min.		Max.
$t_{TLH}$ $t_{THL}$	Output Transition Time	2.0			25	75		95		110	ns
		4.5			7	15		19		22	
		6.0			6	13		16		19	
$t_{PLH}$ $t_{PHL}$	Propagation Delay Time (CLOCK - Q)	2.0			48	125		155		190	ns
		4.5			16	25		31		38	
		6.0			14	21		26		32	
$t_{PLH}$ $t_{PHL}$	Propagation Delay Time (CLOCK - CARRY)	2.0			57	150		190		225	ns
		4.5			19	30		38		45	
		6.0			16	26		32		38	
$t_{PLH}$ $t_{PHL}$	Propagation Delay Time (TE - CARRY)	2.0			39	100		125		150	ns
		4.5			13	20		25		30	
		6.0			11	17		21		26	
$t_{PLH}$	Propagation Delay Time ( $\overline{\text{CLEAR}}$ - Q)	2.0			60	150		190		225	ns
		4.5			20	30		38		45	
		6.0			17	26		32		38	
$t_{PHL}$	Propagation Delay Time ( $\overline{\text{CLEAR}}$ - CARRY)	2.0			72	200		250		300	ns
		4.5			24	40		50		60	
		6.0			20	34		43		51	
$f_{MAX}$	Maximum Clock Frequency	2.0		6.2	18		5		4.2		MHz
		4.5		31	53		25		21		
		6.0		37	62		30		25		
$t_{W(H)}$ $t_{W(L)}$	Minimum Pulse Width (CLOCK)	2.0			18	75		95		110	ns
		4.5			6	15		19		22	
		6.0			6	13		16		19	
$t_{W(L)}$	Minimum Pulse Width (CLEAR)	2.0			24	75		95		110	ns
		4.5			7	15		19		22	
		6.0			6	13		16		19	
$t_s$	Minimum Set-up Time ( $\overline{\text{LOAD}}$ , PE, TE)	2.0			40	100		125		150	ns
		4.5			10	20		25		30	
		6.0			8	17		21		26	
$t_s$	Minimum Set-up Time (A, B, C, D)	2.0			20	75		95		110	ns
		4.5			5	15		19		22	
		6.0			3	13		16		19	
$t_h$	Minimum Hold Time (A, B - CLOCK)	2.0				0		0		0	ns
		4.5				0		0		0	
		6.0				0		0		0	
$t_{REM}$	Minimum Removal Time	2.0			18	50		65		75	ns
		4.5			4	10		13		15	
		6.0			3	9		11		13	

**CAPACITIVE CHARACTERISTICS**

Symbol	Parameter	Test Condition		Value						Unit	
		V <sub>CC</sub> (V)		T <sub>A</sub> = 25°C			-40 to 85°C		-55 to 125°C		
				Min.	Typ.	Max.	Min.	Max.	Min.		Max.
C <sub>IN</sub>	Input Capacitance	5.0			5	10		10		10	pF
C <sub>PD</sub>	Power Dissipation Capacitance (note 1)	5.0			50						pF

1) C<sub>PD</sub> is defined as the value of the IC's internal equivalent capacitance which is calculated from the operating current consumption without load. (Refer to Test Circuit). Average operating current can be obtained by the following equation.  $I_{CC(opr)} = C_{PD} \times V_{CC} \times f_{IN} + I_{CC}$

**TEST CIRCUIT**

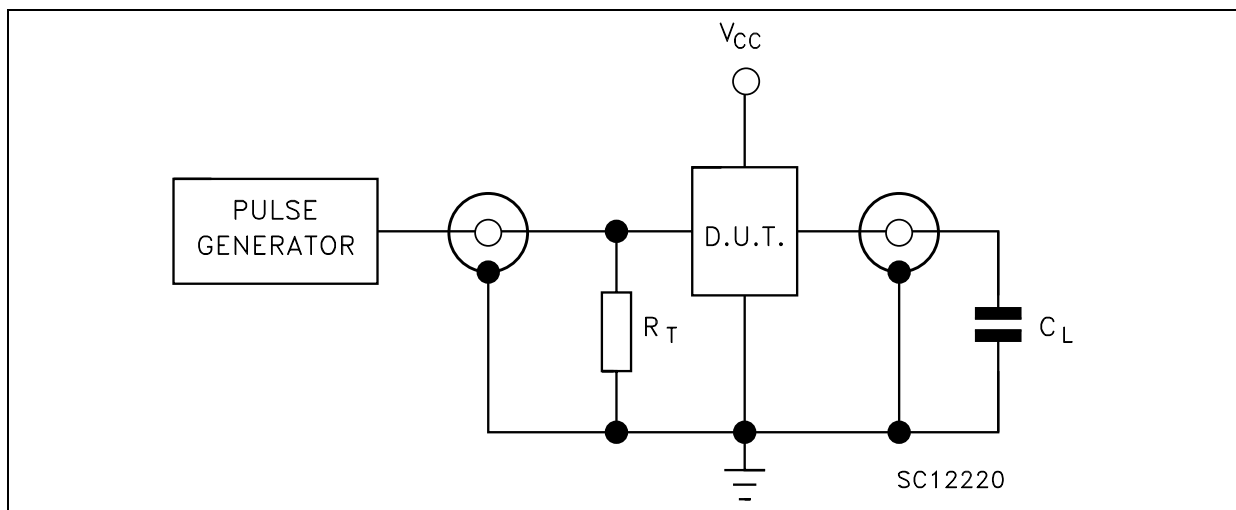

C<sub>L</sub> = 50pF or equivalent (includes jig and probe capacitance)  
 R<sub>T</sub> = Z<sub>OUT</sub> of pulse generator (typically 50Ω)

**WAVEFORM 1: PROPAGATION DELAY TIMES, CLOCK MINIMUM PULSE WIDTH**

(f=1MHz; 50% duty cycle)

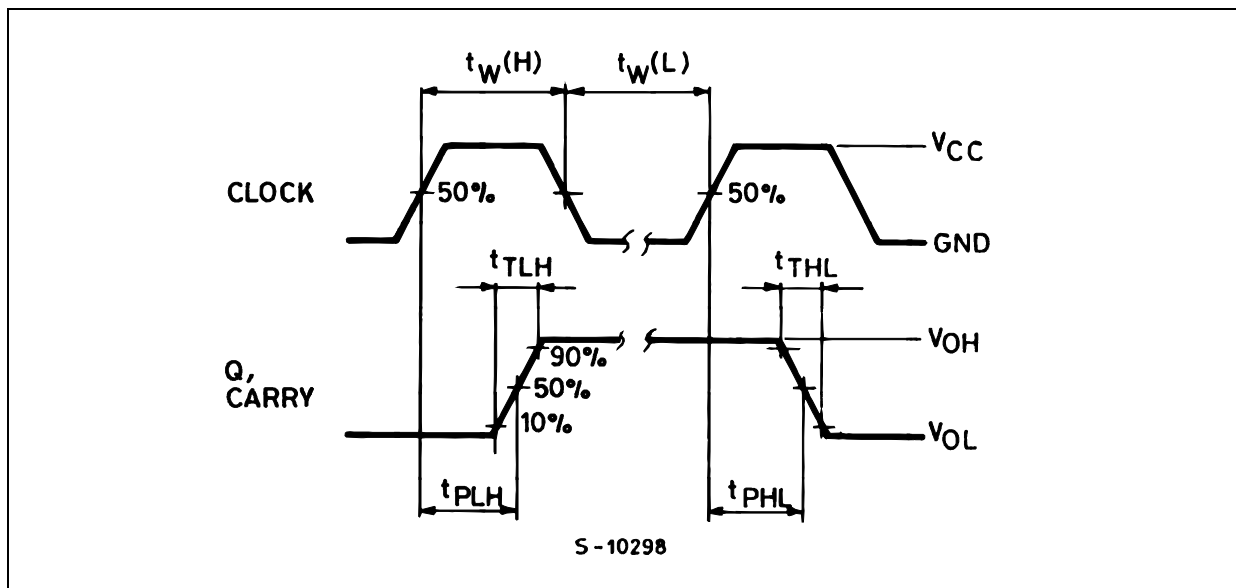

S - 10298

**Plastic DIP-16 (0.25) MECHANICAL DATA**

DIM.	mm.			inch		
	MIN.	TYP	MAX.	MIN.	TYP.	MAX.
a1	0.51			0.020		
B	0.77		1.65	0.030		0.065
b		0.5			0.020	
b1		0.25			0.010	
D			20			0.787
E		8.5			0.335	
e		2.54			0.100	
e3		17.78			0.700	
F			7.1			0.280
I			5.1			0.201
L		3.3			0.130	
Z			1.27			0.050

