

## CMOS Programmable Micropower Positive Voltage Regulator

The ICL7663S Super Programmable Micropower Voltage Regulator is a low power, high efficiency positive voltage regulator which accepts 1.6V to 16V inputs and provides adjustable outputs from 1.3V to 16V at currents up to 40mA.

It is a direct replacement for the industry standard ICL7663B offering **wider** operating voltage and temperature ranges, **improved** output accuracy (ICL7663SA), better temperature coefficient, **guaranteed** maximum supply current, and guaranteed line and load regulation. All improvements are highlighted in the electrical characteristics section. **Critical parameters are guaranteed over the entire commercial and industrial temperature ranges.** The ICL7663S/SA programmable output voltage is set by two external resistors. The 1% reference accuracy of the ICL7663SA eliminates the need for trimming the output voltage in most applications.

The ICL7663S is well suited for battery powered supplies, featuring 4 $\mu$ A quiescent current, low  $V_{IN}$  to  $V_{OUT}$  differential, output current sensing and logic input level shutdown control. In addition, the ICL7663S has a negative temperature coefficient output suitable for generating a temperature compensated display drive voltage for LCD displays.

### Pinout

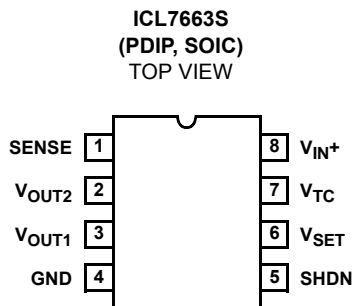

### Features

- *Guaranteed* 10 $\mu$ A Maximum Quiescent Current Over All Temperature Ranges
- *Wider* Operating Voltage Range - 1.6V to 16V
- *Guaranteed* Line and Load Regulation Over Entire Operating Temperature Range *Optional*
- 1% Output Voltage Accuracy (ICL7663SA)
- Output Voltage Programmable from 1.3V to 16V
- *Improved* Temperature Coefficient of Output Voltage
- 40mA Minimum Output Current with Current Limiting
- Output Voltages with Programmable Negative Temperature Coefficients
- Output Shutdown via Current-Limit Sensing or External Logic Level
- Low Input-to-Output Voltage Differential
- Improved Direct Replacement for Industry Standard ICL7663B and Other Second-Source Products
- Pb-Free Plus Anneal Available (RoHS Compliant)

### Applications

- Low-Power Portable Instrumentation
- Pagers
- Handheld Instruments
- LCD Display Modules
- Remote Data Loggers
- Battery-Powered Systems

**Ordering Information**

PART NUMBER	TEMP. RANGE (°C)	PACKAGE	PKG. DWG. #
ICL7663SCBA*	0 to 70	8 Ld SOIC (N)	M8.15
ICL7663SCBAZA* (See Note)	0 to 70	8 Ld SOIC (N) (Pb-free)	M8.15
ICL7663SCPA	0 to 70	8 Ld PDIP	E8.3
ICL7663SCPAZ (See Note)	0 to 70	8 Ld PDIP** (Pb-free)	E8.3
ICL7663SACBA*	0 to 70	8 Ld SOIC (N)	M8.15
ICL7663SACBAZA* (See Note)	0 to 70	8 Ld SOIC (N) (Pb-free)	M8.15
ICL7663SACPA	0 to 70	8 Ld PDIP	E8.3
ICL7663SAIBA	-25 to 85	8 Ld SOIC (N)	M8.15
ICL7663SAIBAZA (See Note)	-25 to 85	8 Ld SOIC (N) (Pb-free)	M8.15

\*Add "-T" suffix to part number for tape and reel packaging.

\*\*Pb-free PDIPs can be used for through hole wave solder processing only. They are not intended for use in Reflow solder processing applications.

NOTE: Intersil Pb-free plus anneal products employ special Pb-free material sets; molding compounds/die attach materials and 100% matte tin plate termination finish, which are RoHS compliant and compatible with both SnPb and Pb-free soldering operations. Intersil Pb-free products are MSL classified at Pb-free peak reflow temperatures that meet or exceed the Pb-free requirements of IPC/JEDEC J STD-020.

# ICL7663S

## Absolute Maximum Ratings

Input Supply Voltage	+18V
Any Input or Output Voltage (Note 1)	
Terminals 1, 2, 3, 5, 6, 7	$V_{IN} + 0.3V$ to GND -0.3V
Output Source Current	
Terminal 2	50mA
Terminal 3	25mA
Output Sinking Current	
Terminal 7	-10mA

## Operating Conditions

Temperature Range	
ICL7663SC	0°C to 70°C
ICL7663SI	-25°C to 85°C

## Thermal Information

Thermal Resistance (Typical, Note 2)	$\theta_{JA}$ (°C/W)	$\theta_{JC}$ (°C/W)
CERDIP Package	115	30
PDIP Package*	150	N/A
Plastic SOIC Package	180	N/A
Maximum Junction Temperature		
PDIP Package	150°C	
CERDIP Package	175°C	
Maximum Storage Temperature Range	-65°C to 150°C	
Maximum Lead Temperature (Soldering 10s)	300°C (SOIC - Lead Tips Only)	

\*Pb-free PDIPs can be used for through hole wave solder processing only. They are not intended for use in Reflow solder processing applications.

**CAUTION:** Stresses above those listed in "Absolute Maximum Ratings" may cause permanent damage to the device. This is a stress only rating and operation of the device at these or any other conditions above those indicated in the operational sections of this specification is not implied.

### NOTES:

1. Connecting any terminal to voltages greater than ( $V_{IN} + 0.3V$ ) or less than (GND - 0.3V) may cause destructive device latch-up. It is recommended that no inputs from sources operating on external power supplies be applied prior to ICL7663S power-up.
2.  $\theta_{JA}$  is measured with the component mounted on an evaluation PC board in free air.

**Electrical Specifications** Specifications Below Applicable to Both ICL7663S and ICL7663SA, Unless Otherwise Specified.  $V_{IN} = 9V$ ,  $V_{OUT} = 5V$ ,  $T_A = 25^\circ C$ , Unless Otherwise Specified. Notes 4, 5. See Test Circuit, Figure 7

PARAMETER	SYMBOL	TEST CONDITIONS	MIN	TYP	MAX	UNITS		
Input Voltage	$V_{IN}$	ICL7663S	$T_A = 25^\circ C$	1.5	-	16	V	
			$0^\circ C < T_A < 70^\circ C$	1.6	-	16	V	
			$-25^\circ C < T_A < 85^\circ C$	1.6	-	16	V	
		ICL7663SA	$0^\circ C < T_A < 70^\circ C$	1.6	-	16	V	
			$-25^\circ C < T_A < 85^\circ C$	1.6	-	16	V	
Quiescent Current	$I_Q$	$1.4V \leq V_{OUT} \leq 8.5V$ , No Load $V_{IN} = 9V$	$0^\circ C < T_A < 70^\circ C$	-	-	10	$\mu A$	
			$-25^\circ C < T_A < 85^\circ C$	-	-	10	$\mu A$	
			$V_{IN} = 16V$	$0^\circ C < T_A < 70^\circ C$	-	-	12	$\mu A$
				$-25^\circ C < T_A < 85^\circ C$	-	-	12	$\mu A$
Reference Voltage	$V_{SET}$	$I_{OUT1} = 100\mu A$ , $V_{OUT} = V_{SET}$	ICL7663S $T_A = 25^\circ C$	1.2	1.3	1.4	V	
			ICL7663SA $T_A = 25^\circ C$	1.275	1.29	1.305	V	
Temperature Coefficient	$\frac{\Delta V_{SET}}{\Delta T}$	$0^\circ C < T_A < 70^\circ C$	-	100	-	ppm		
		$-25^\circ C < T_A < 85^\circ C$	-	100	-	ppm		
Line Regulation	$\frac{\Delta V_{SET}}{V_{SET} \cdot \Delta V_{IN}}$	$2V < V_{IN} < 15V$	$0^\circ C < T_A < 70^\circ C$	-	0.03	-	%/V	
			$-25^\circ C < T_A < 85^\circ C$	-	0.03	0.3	%/V	
$V_{SET}$ Input Current	$I_{SET}$	$0^\circ C < T_A < 70^\circ C$	-	0.01	10	nA		
		$-25^\circ C < T_A < 85^\circ C$	-	0.01	10	nA		
Shutdown Input Current	$I_{SHDN}$		-	$\pm 0.01$	10	nA		
Shutdown Input Voltage	$V_{SHDN}$	$V_{SHDN}$ HI: Both $V_{OUT}$ Disabled	1.4	-	-	V		
		$V_{SHDN}$ LO: Both $V_{OUT}$ Enable	-	-	0.3	V		
Sense Pin Input Current	$I_{SENSE}$		-	0.01	10	nA		

# ICL7663S

**Electrical Specifications** Specifications Below Applicable to Both ICL7663S and ICL7663SA, Unless Otherwise Specified.  $V_{+IN} = 9V$ ,  $V_{OUT} = 5V$ ,  $T_A = 25^\circ C$ , Unless Otherwise Specified. Notes 4, 5. See Test Circuit, Figure 7 (Continued)

PARAMETER	SYMBOL	TEST CONDITIONS	MIN	TYP	MAX	UNITS	
Sense Pin Input Threshold	$V_{CL}$		-	0.5	-	V	
Input-Output Saturation Resistance (Note 3)	$R_{SAT}$	$V_{+IN} = 2V, I_{OUT1} = 1mA$	-	170	350	$\Omega$	
		$V_{+IN} = 9V, I_{OUT1} = 2mA$	-	50	100	$\Omega$	
		$V_{+IN} = 15V, I_{OUT1} = 5mA$	-	35	70	$\Omega$	
Load Regulation	$\frac{\Delta V_{OUT}}{\Delta I_{OUT}}$	$1mA < I_{OUT2} < 20mA$	-	1	3	$\Omega$	
		$50\mu A < I_{OUT1} < 5mA$	-	2	10	$\Omega$	
Available Output Current ( $V_{OUT2}$ )	$I_{OUT2}$	$3V \leq V_{IN} \leq 16V, V_{IN} - V_{OUT2} = 1.5V$	40	-	-	mA	
Negative Tempco Output (Note 4)	$V_{TC}$	Open Circuit Voltage	-	0.9	-	V	
	$I_{TC}$	Maximum Sink Current	0	8	2.0	mA	
Temperature Coefficient	$\frac{\Delta V_{TC}}{\Delta T}$	Open Circuit	-	+2.5	-	$mV/^\circ C$	
Minimum Load Current	$I_{L(MIN)}$	Includes $V_{SET}$ Divider	$T_A = 25^\circ C$	-	-	1.0	$\mu A$
			$0^\circ C < T_A < 70^\circ C$	-	0.2	5.0	$\mu A$
			$-25^\circ C < T_A < 85^\circ C$	-	0.2	5.0	$\mu A$

**NOTES:**

- This parameter refers to the saturation resistance of the MOS pass transistor. The minimum input-output voltage differential at low current (under 5mA), can be determined by multiplying the load current (including set resistor current, but not quiescent current) by this resistance.
- This output has a positive temperature coefficient. Using it in combination with the inverting input of the regulator at  $V_{SET}$ , a negative coefficient results in the output voltage. See Figure 9 for details. Pin will not source current.
- All pins are designed to withstand electrostatic discharge (ESD) levels in excess of 2000V.
- All significant improvements over the industry standard ICL7663 are highlighted.

## Functional Diagram

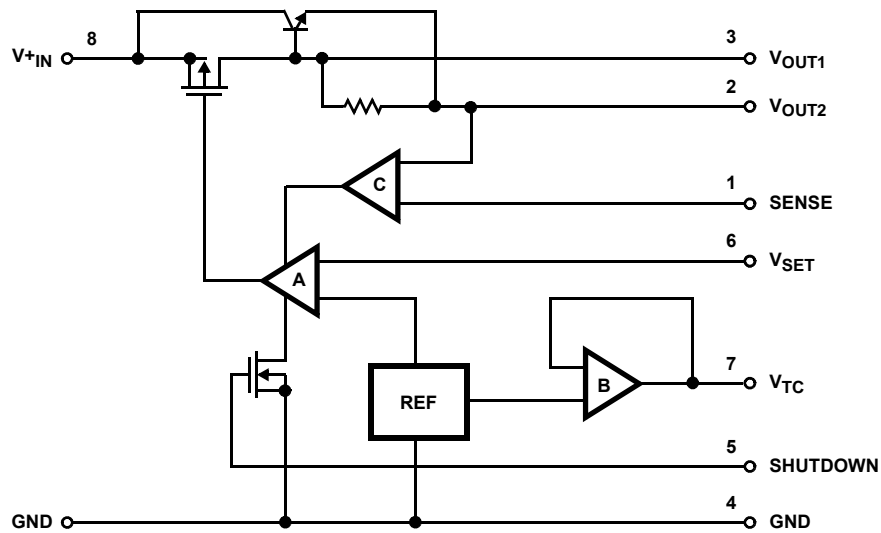

### Detailed Description

The ICL7663S is a CMOS integrated circuit incorporating all the functions of a voltage regulator plus protection circuitry on a single monolithic chip. Referring to the Functional Diagram, the main blocks are a bandgap-type voltage reference, an error amplifier, and an output driver with both PMOS and NPN pass transistors.

The bandgap output voltage, trimmed to  $1.29V \pm 15mV$  for the ICL7663SA, and the input voltage at the  $V_{SET}$  terminal are compared in amplifier A. Error amplifier A drives a P-channel pass transistor which is sufficient for low (under about 5mA) currents. The high current output is passed by an NPN bipolar transistor connected as a follower. This configuration gives more gain and lower output impedance.

Logic-controlled shutdown is implemented via a N-Channel MOS transistor. Current-sensing is achieved with comparator C, which functions with the  $V_{OUT2}$  terminal. The ICL7663S has an output ( $V_{TC}$ ) from a buffer amplifier (B), which can be used in combination with amplifier A to generate programmable-temperature-coefficient output voltages.

The amplifier, reference and comparator circuitry all operate at bias levels well below  $1\mu A$  to achieve extremely low quiescent current. This does limit the dynamic response of the circuits, however, and transients are best dealt with outside the regulator loop.

### Basic Operation

The ICL7663S is designed to regulate battery voltages in the 5V to 15V region at maximum load currents of about 5mA to 30mA. Although intended as low power devices, power dissipation limits must be observed. For example, the power dissipation in the case of a 10V supply regulated down to 2V with a load current of 30mA clearly exceeds the power dissipation rating of the Mini-DIP:

$$(10 - 2) (30) (10^{-3}) = 240mW$$

The circuit of Figure 8 illustrates proper use of the device.

CMOS devices generally require two precautions: every input pin must go somewhere, and maximum values of applied voltages and current limits must be rigorously observed. Neglecting these precautions may lead to, at the least, incorrect or nonoperation, and at worst, destructive device failure. To avoid the problem of latchup, do not apply inputs to any pins before supply voltage is applied.

**Input Voltages** - The ICL7663S accepts working inputs of 1.5V to 16V. When power is applied, the rate-of-rise of the input may be hundreds of volts per microsecond. This is potentially harmful to the regulators, where internal operating currents are in the nanoampere range. The  $0.047\mu F$  capacitor on the device side of the switch will limit inputs to a safe level around  $2V/\mu s$ . Use of this capacitor is suggested in all applications. In severe rate-of-rise cases, it

may be advisable to use an RC network on the SHutDown pin to delay output turn-on. Battery charging surges, transients, and assorted noise signals should be kept from the regulators by RC filtering, zener protection, or even fusing.

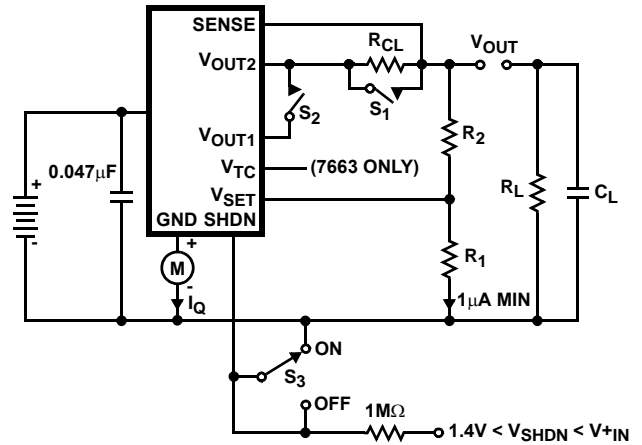

NOTES:

7.  $S_1$  when closed disables output current limiting.
8. Close  $S_2$  for  $V_{OUT1}$ , open  $S_2$  for  $V_{OUT2}$ .
9.  $I_Q$  quiescent currents measured at GND pin by meter M.
10.  $S_3$  when ON, permits normal operation, when OFF, shuts down both  $V_{OUT1}$  and  $V_{OUT2}$ .

FIGURE 7. ICL7663S TEST CIRCUIT

**Output Voltages** - The resistor divider  $R_2/R_1$  is used to scale the reference voltage,  $V_{SET}$ , to the desired output using the formula  $V_{OUT} = (1 + R_2/R_1) V_{SET}$ . Suitable arrangements of these resistors, using a potentiometer, enables exact values for  $V_{OUT}$  to be obtained. In most applications the potentiometer may be eliminated by using the ICL7663SA. The ICL7663SA has  $V_{SET}$  voltage guaranteed to be  $1.29V \pm 15mV$  and when used with  $\pm 1\%$  tolerance resistors for  $R_1$  and  $R_2$  the initial output voltage will be within  $\pm 2.7\%$  of ideal.

The low leakage current of the  $V_{SET}$  terminal allows  $R_1$  and  $R_2$  to be tens of megohms for minimum additional quiescent drain current. However, some load current is required for proper operation, so for extremely low-drain applications it is necessary to draw at least  $1\mu A$ . This can include the current for  $R_2$  and  $R_1$ .

Output voltages up to nearly the  $V_{IN}$  supply may be obtained at low load currents, while the low limit is the reference voltage. The minimum input-output differential in each regulator is obtained using the  $V_{OUT1}$  terminal. The input-output differential increases to 1.5V when using  $V_{OUT2}$ .

**Output Currents** - Low output currents of less than 5mA are obtained with the least input-output differential from the  $V_{OUT1}$  terminal (connect  $V_{OUT2}$  to  $V_{OUT1}$ ). Where higher currents are needed, use  $V_{OUT2}$  ( $V_{OUT1}$ , should be left open in this case).

# Plastic Packages for Integrated Circuits

## Dual-In-Line Plastic Packages (PDIP)

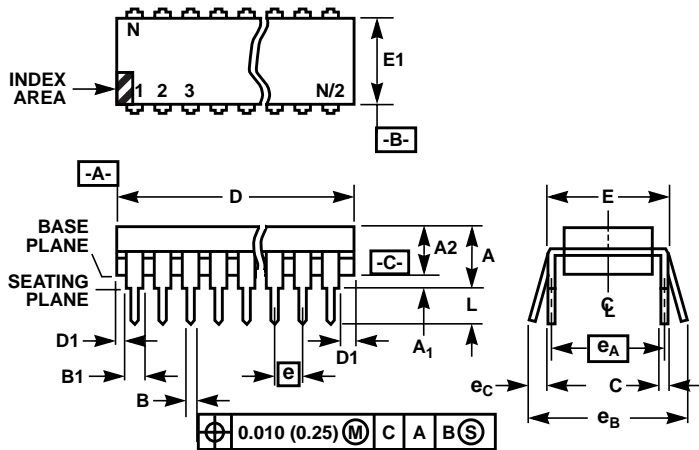

### NOTES:

- Controlling Dimensions: INCH. In case of conflict between English and Metric dimensions, the inch dimensions control.
- Dimensioning and tolerancing per ANSI Y14.5M-1982.
- Symbols are defined in the "MO Series Symbol List" in Section 2.2 of Publication No. 95.
- Dimensions A, A1 and L are measured with the package seated in JEDEC seating plane gauge GS-3.
- D, D1, and E1 dimensions do not include mold flash or protrusions. Mold flash or protrusions shall not exceed 0.010 inch (0.25mm).
- E and  $e_A$  are measured with the leads constrained to be perpendicular to datum  $-C-$ .
- $e_B$  and  $e_C$  are measured at the lead tips with the leads unconstrained.  $e_C$  must be zero or greater.
- B1 maximum dimensions do not include dambar protrusions. Dambar protrusions shall not exceed 0.010 inch (0.25mm).
- N is the maximum number of terminal positions.
- Corner leads (1, N, N/2 and N/2 + 1) for E8.3, E16.3, E18.3, E28.3, E42.6 will have a B1 dimension of 0.030 - 0.045 inch (0.76 - 1.14mm).

### E8.3 (JEDEC MS-001-BA ISSUE D) 8 LEAD DUAL-IN-LINE PLASTIC PACKAGE

SYMBOL	INCHES		MILLIMETERS		NOTES
	MIN	MAX	MIN	MAX	
A	-	0.210	-	5.33	4
A1	0.015	-	0.39	-	4
A2	0.115	0.195	2.93	4.95	-
B	0.014	0.022	0.356	0.558	-
B1	0.045	0.070	1.15	1.77	8, 10
C	0.008	0.014	0.204	0.355	-
D	0.355	0.400	9.01	10.16	5
D1	0.005	-	0.13	-	5
E	0.300	0.325	7.62	8.25	6
E1	0.240	0.280	6.10	7.11	5
e	0.100 BSC		2.54 BSC		-
$e_A$	0.300 BSC		7.62 BSC		6
$e_B$	-	0.430	-	10.92	7
L	0.115	0.150	2.93	3.81	4
N	8		8		9